



**Advanced A/D Flash MCU with EEPROM**

**HT66F2350/HT66F2360**

**HT66F2370/HT66F2390**

Revision: V1.70 Date: November 19, 2019

## Table of Contents

|  |           |
|--|-----------|
| <b>Features</b> .....  | <b>7</b>  |
| CPU Features .....   | 7         |
| Peripheral Features.....   | 7         |
| <b>General Description</b> .....                                       | <b>8</b>  |
| <b>Selection Table</b> .....   | <b>9</b>  |
| <b>Block Diagram</b> .....   | <b>9</b>  |
| <b>Pin Assignment</b> .....  | <b>10</b> |
| <b>Pin Descriptions</b> .....  | <b>12</b> |
| <b>Absolute Maximum Ratings</b> .....                                  | <b>24</b> |
| <b>D.C. Characteristics</b> .....                                      | <b>24</b> |
| Operating Voltage Characteristics.....                                 | 24        |
| Standby Current Characteristics .....                                  | 25        |
| Operating Current Characteristics.....                                 | 26        |
| <b>A.C. Characteristics</b> .....                                      | <b>27</b> |
| High Speed Internal Oscillator – HIRC – Frequency Accuracy .....       | 27        |
| Low Speed Internal Oscillator Characteristics – LIRC .....             | 27        |
| Low Speed Crystal Oscillator Characteristics – LXT.....                | 27        |
| Operating Frequency Characteristic Curves .....                        | 28        |
| System Start Up Time Characteristics .....                             | 28        |
| <b>Input/Output Characteristics</b> .....                              | <b>29</b> |
| <b>Memory Characteristics</b> .....                                    | <b>29</b> |
| <b>A/D Converter Electrical Characteristics</b> .....                  | <b>30</b> |
| <b>Comparator Electrical Characteristics</b> .....                     | <b>31</b> |
| <b>Software Controlled LCD Driver Electrical Characteristics</b> ..... | <b>31</b> |
| <b>I<sup>2</sup>C Characteristics</b> .....                            | <b>32</b> |
| <b>LVD/LVR Electrical Characteristics</b> .....                        | <b>32</b> |
| <b>Power-on Reset Characteristics</b> .....                            | <b>33</b> |
| <b>System Architecture</b> .....                                       | <b>34</b> |
| Clocking and Pipelining.....   | 34        |
| Program Counter.....   | 35        |
| Stack .....  | 36        |
| Arithmetic and Logic Unit – ALU .....                                  | 36        |
| <b>Flash Program Memory</b> .....                                      | <b>37</b> |
| Structure.....   | 37        |
| Special Vectors .....  | 38        |
| Look-up Table.....   | 38        |
| Table Program Example .....  | 38        |
| In Circuit Programming – ICP .....                                     | 39        |

|  |           |
|--|-----------|
| On-Chip Debug Support – OCDS .....                     | 40        |
| In Application Programming – IAP .....                 | 41        |
| <b>Data Memory .....</b>                               | <b>50</b> |
| Structure.....   | 50        |
| Data Memory Addressing.....                            | 51        |
| General Purpose Data Memory .....                      | 51        |
| Special Purpose Data Memory .....                      | 51        |
| <b>Special Function Register Description.....</b>      | <b>55</b> |
| Indirect Addressing Registers – IAR0, IAR1, IAR2 ..... | 55        |
| Memory Pointers – MP0, MP1H/MP1L, MP2H/MP2L.....       | 55        |
| Program Memory Bank Pointer – PBP.....                 | 57        |
| Accumulator – ACC.....                                 | 58        |
| Program Counter Low Register – PCL.....                | 58        |
| Look-up Table Registers – TBLP, TBHP, TBLH.....        | 58        |
| Status Register – STATUS.....                          | 59        |
| <b>EEPROM Data Memory.....</b>                         | <b>61</b> |
| EEPROM Data Memory Structure .....                     | 61        |
| EEPROM Registers .....                                 | 61        |
| Reading Data from the EEPROM .....                     | 63        |
| Writing Data to the EEPROM.....                        | 64        |
| Write Protection.....                                  | 64        |
| EEPROM Interrupt .....                                 | 64        |
| Programming Considerations.....                        | 65        |
| <b>Oscillators .....</b>                               | <b>66</b> |
| Oscillator Overview .....                              | 66        |
| System Clock Configurations.....                       | 66        |
| External Crystal/Ceramic Oscillator – HXT .....        | 67        |
| Internal High Speed RC Oscillator – HIRC .....         | 68        |
| External 32.768kHz Crystal Oscillator – LXT .....      | 68        |
| Internal 32kHz Oscillator – LIRC.....                  | 69        |
| <b>Operating Modes and System Clocks .....</b>         | <b>69</b> |
| System Clocks .....                                    | 69        |
| System Operation Modes.....                            | 71        |
| Control Registers .....                                | 72        |
| Operating Mode Switching.....                          | 74        |
| Standby Current Considerations .....                   | 78        |
| Wake-up .....  | 78        |
| <b>Watchdog Timer.....</b>                             | <b>79</b> |
| Watchdog Timer Clock Source.....                       | 79        |
| Watchdog Timer Control Register .....                  | 79        |
| Watchdog Timer Operation .....                         | 80        |
| <b>Reset and Initialisation.....</b>                   | <b>81</b> |
| Reset Functions .....                                  | 81        |
| Reset Initial Conditions .....                         | 85        |

|   |            |
|---|------------|
| <b>Input/Output Ports .....</b>             | <b>91</b>  |
| Pull-high Resistors .....                   | 92         |
| Port A Wake-up .....                        | 93         |
| I/O Port Control Registers .....            | 93         |
| I/O Port Source Current Control.....        | 94         |
| I/O Port Power Source Control.....          | 96         |
| Pin-shared Functions .....                  | 97         |
| I/O Pin Structures.....                     | 108        |
| Read Port Function .....                    | 109        |
| Programming Considerations.....             | 110        |
| <b>Timer Modules – TM .....</b>             | <b>111</b> |
| Introduction .....                          | 111        |
| TM Operation .....                          | 111        |
| TM Clock Source.....                        | 112        |
| TM Interrupts.....                          | 112        |
| TM External Pins.....                       | 112        |
| TM Input/Output Pin Selection .....         | 113        |
| Programming Considerations.....             | 114        |
| <b>Standard Type TM – STM .....</b>         | <b>115</b> |
| Standard TM Operation.....                  | 115        |
| Standard Type TM Register Description ..... | 116        |
| Standard Type TM Operation Modes .....      | 120        |
| <b>Periodic Type TM – PTM.....</b>          | <b>130</b> |
| Periodic TM Operation .....                 | 131        |
| Periodic Type TM Register Description.....  | 131        |
| Periodic Type TM Operation Modes.....       | 136        |
| <b>Analog to Digital Converter .....</b>    | <b>145</b> |
| A/D Overview .....                          | 145        |
| Registers Descriptions .....                | 146        |
| A/D Converter Reference Voltage.....        | 150        |
| A/D Converter Input Signals.....            | 151        |
| A/D Operation .....                         | 152        |
| Conversion Rate and Timing Diagram .....    | 153        |
| Summary of A/D Conversion Steps.....        | 154        |
| Programming Considerations.....             | 155        |
| A/D Transfer Function .....                 | 155        |
| A/D Programming Examples.....               | 156        |
| <b>Serial Interface Module – SIM.....</b>   | <b>158</b> |
| SPI Interface .....                         | 158        |
| I <sup>2</sup> C Interface .....            | 164        |
| <b>Serial Interface – SPIA.....</b>         | <b>174</b> |
| SPIA Interface Operation .....              | 174        |
| SPIA Registers .....                        | 175        |
| SPIA Communication .....                    | 178        |

|   |            |
|---|------------|
| SPIA Bus Enable/Disable .....                         | 180        |
| SPIA Operation .....                                  | 180        |
| Error Detection .....                                 | 181        |
| <b>UART Interface .....</b>                           | <b>182</b> |
| UART External Pin .....                               | 183        |
| UART Data Transfer Scheme.....                        | 183        |
| UART Status and Control Registers.....                | 183        |
| Baud Rate Generator .....                             | 189        |
| UART Setup and Control.....                           | 190        |
| UART Transmitter.....                                 | 191        |
| UART Receiver .....                                   | 192        |
| Managing Receiver Errors .....                        | 194        |
| UART Interrupt Structure.....                         | 195        |
| UART Power Down and Wake-up.....                      | 196        |
| <b>Comparators .....</b>                              | <b>197</b> |
| Comparator Operation .....                            | 197        |
| Comparator Registers .....                            | 197        |
| Input Offset Calibration .....                        | 199        |
| Comparator Interrupt.....                             | 199        |
| Programming Considerations.....                       | 199        |
| <b>Software Controlled LCD Driver.....</b>            | <b>200</b> |
| LCD Operation .....                                   | 200        |
| LCD Bias Current Control .....                        | 201        |
| <b>16-bit Multiplication Division Unit – MDU.....</b> | <b>202</b> |
| MDU Registers.....                                    | 202        |
| MDU Operation .....                                   | 203        |
| <b>Cyclic Redundancy Check – CRC .....</b>            | <b>205</b> |
| CRC Registers .....                                   | 205        |
| CRC Operation.....                                    | 206        |
| <b>Low Voltage Detector – LVD .....</b>               | <b>208</b> |
| LVD Register .....                                    | 208        |
| LVD Operation.....                                    | 209        |
| <b>Interrupts .....</b>                               | <b>209</b> |
| Interrupt Registers.....                              | 209        |
| Interrupt Operation .....                             | 220        |
| External Interrupt.....                               | 223        |
| Comparator Interrupt.....                             | 223        |
| Multi-function Interrupt .....                        | 223        |
| A/D Converter Interrupt.....                          | 224        |
| Time Base Interrupt.....                              | 224        |
| TM Interrupt.....                                     | 226        |
| LVD Interrupt.....                                    | 226        |
| EEPROM Interrupt .....                                | 226        |

|  |            |
|--|------------|
| Serial Interface Module Interrupt.....         | 227        |
| SPIA Interface Interrupt.....                  | 227        |
| UART Transfer Interrupt.....                   | 227        |
| Interrupt Wake-up Function.....                | 227        |
| Programming Considerations.....                | 228        |
| <b>Application Circuits.....</b>               | <b>229</b> |
| <b>Instruction Set.....</b>                    | <b>230</b> |
| Introduction .....                             | 230        |
| Instruction Timing .....                       | 230        |
| Moving and Transferring Data.....              | 230        |
| Arithmetic Operations.....                     | 230        |
| Logical and Rotate Operation .....             | 231        |
| Branches and Control Transfer .....            | 231        |
| Bit Operations .....                           | 231        |
| Table Read Operations .....                    | 231        |
| Other Operations.....                          | 231        |
| <b>Instruction Set Summary .....</b>           | <b>232</b> |
| Table Conventions.....                         | 232        |
| Extended Instruction Set.....                  | 234        |
| <b>Instruction Definition.....</b>             | <b>236</b> |
| Extended Instruction Definition .....          | 245        |
| <b>Package Information .....</b>               | <b>252</b> |
| 48-pin LQFP (7mm×7mm) Outline Dimensions ..... | 253        |
| 64-pin LQFP (7mm×7mm) Outline Dimensions ..... | 254        |

## Features

### CPU Features

- Operating voltage
  - ♦  $f_{SYS}=8\text{MHz}$ : 2.2V~5.5V
  - ♦  $f_{SYS}=12\text{MHz}$ : 2.7V~5.5V
  - ♦  $f_{SYS}=16\text{MHz}$ : 3.3V~5.5V
- Up to 0.25 $\mu\text{s}$  instruction cycle with 16MHz system clock at  $V_{DD}=5\text{V}$
- Power down and wake-up functions to reduce power consumption
- Oscillator type
  - ♦ External High Speed Crystal – HXT
  - ♦ Internal High Speed RC – HIRC
  - ♦ External 32.768kHz Crystal – LXT
  - ♦ Internal 32kHz RC – LIRC
- Fully integrated internal 8/12/16MHz oscillator requires no external components
- Multi-mode operation: FAST, SLOW, IDLE and SLEEP
- All instructions executed in one to three instruction cycles
- Table read instructions
- 115 powerful instructions
- 16-level subroutine nesting
- Bit manipulation instruction

### Peripheral Features

- Program Memory: Up to 64K $\times$ 16
- Data Memory: Up to 4096 $\times$ 8
- True EEPROM Memory: Up to 1024 $\times$ 8
- Watchdog Timer function
- Up to 58 bidirectional I/O lines
- Programming I/O source current
- Software controlled 4-SCOM lines LCD driver with 1/2 bias
- Four external interrupt lines shared with I/O pins
- Multiple Timer Modules for time measure, input capture, compare match output, PWM output function or single pulse output function
- Serial Interfaces Module – SIM for SPI or I<sup>2</sup>C
- Serial Peripheral Interface – SPIA
- Fully-duplex Universal Asynchronous Receiver and Transmitter Interface – UART
- Dual Time-Base functions for generation of fixed time interrupt signals
- Dual comparator functions
- Up to 16 external channels 12-bit resolution A/D converter
- Integrated Multiplier/Divider Unit – MDU
- Integrated 16-bit Cyclic Redundancy Check function – CRC
- Low voltage reset function
- Low voltage detect function
- European standard IEC 60730 and U.S. UL 60730 certified.
- Wide range of package types

## General Description

The series of devices are Flash Memory A/D type 8-bit high performance RISC architecture microcontroller. Offering users the convenience of Flash Memory multi-programming features, these devices also include a wide range of functions and features. Other memory includes an area of RAM Data Memory as well as an area of true EEPROM memory for storage of non-volatile data such as serial number, calibration data, etc.

Analog features include a multi-channel 12-bit A/D converter and dual comparator functions. Multiple and extremely flexible Timer Modules provide timing, pulse generation and PWM generation functions. Communication with the outside world is catered for by including fully integrated SPI, UART or I<sup>2</sup>C interface functions, two popular interfaces which provide designers with a means of easy communication with external peripheral hardware. Protective features such as an internal Watchdog Timer, Low Voltage Reset and Low Voltage Detector coupled with excellent noise immunity and ESD protection ensure that reliable operation is maintained in hostile electrical environments.

A full choice of HXT, LXT, HIRC and LIRC oscillator functions are provided including a fully integrated system oscillator which requires no external components for its implementation. The ability to operate and switch dynamically between a range of operating modes using different clock sources gives users the ability to optimise microcontroller operation and minimise power consumption.

The inclusion of flexible I/O programming features, Time-Base functions along with many other features ensure that the devices will find excellent use in applications such as electronic metering, environmental monitoring, handheld instruments, household appliances, electronically controlled tools, motor driving in addition to many others.

## Selection Table

Most features are common to all devices. The main features distinguishing them are Memory capacity, I/O count and A/D converter channel number. The following table summarises the main features of each device.

| Part No.  | Program Memory | Data Memory | Data EEPROM | I/O | External Interrupt | A/D       | Comparators | Timer Module                                 |
|-----------|----------------|-------------|-------------|-----|--------------------|-----------|-------------|--|
| HT66F2350 | 8k×16          | 768×8       | 256×8       | 44  | 4                  | 12-bit×12 | 2           | 10-bit PTM×2<br>16-bit PTM×2<br>16-bit STM×3 |
| HT66F2360 | 16k×16         | 1536×8      | 256×8       | 58  | 4                  | 12-bit×16 | 2           | 10-bit PTM×2<br>16-bit PTM×2<br>16-bit STM×3 |
| HT66F2370 | 32k×16         | 3072×8      | 512×8       | 58  | 4                  | 12-bit×16 | 2           | 10-bit PTM×2<br>16-bit PTM×2<br>16-bit STM×3 |
| HT66F2390 | 64k×16         | 4096×8      | 1024×8      | 58  | 4                  | 12-bit×16 | 2           | 10-bit PTM×2<br>16-bit PTM×2<br>16-bit STM×3 |

| Part No.  | Time Base | SCOM | Stacks | SIM | SPIA | UART | MDU | CRC | Package   |
|-----------|-----------|------|--------|-----|------|------|-----|-----|-----------|
| HT66F2350 | 2         | 4    | 16     | √   | √    | 2    | √   | √   | 48LQFP    |
| HT66F2360 | 2         | 4    | 16     | √   | √    | 2    | √   | √   | 48/64LQFP |
| HT66F2370 | 2         | 4    | 16     | √   | √    | 3    | √   | √   | 48/64LQFP |
| HT66F2390 | 2         | 4    | 16     | √   | √    | 3    | √   | √   | 48/64LQFP |

Note: As devices exist in more than one package format, the table reflects the situation for the package with the most pins.

## Block Diagram

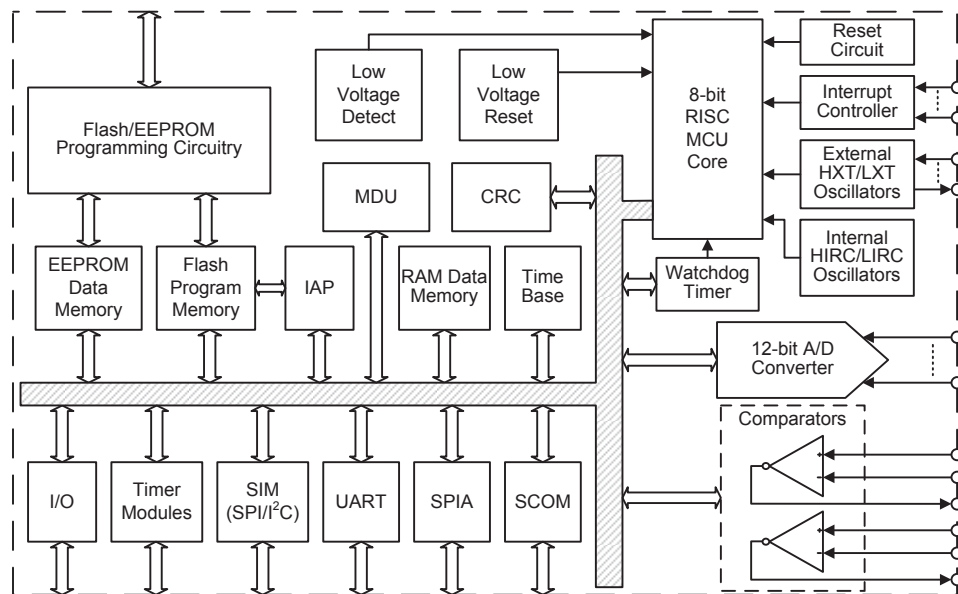

## Pin Assignment

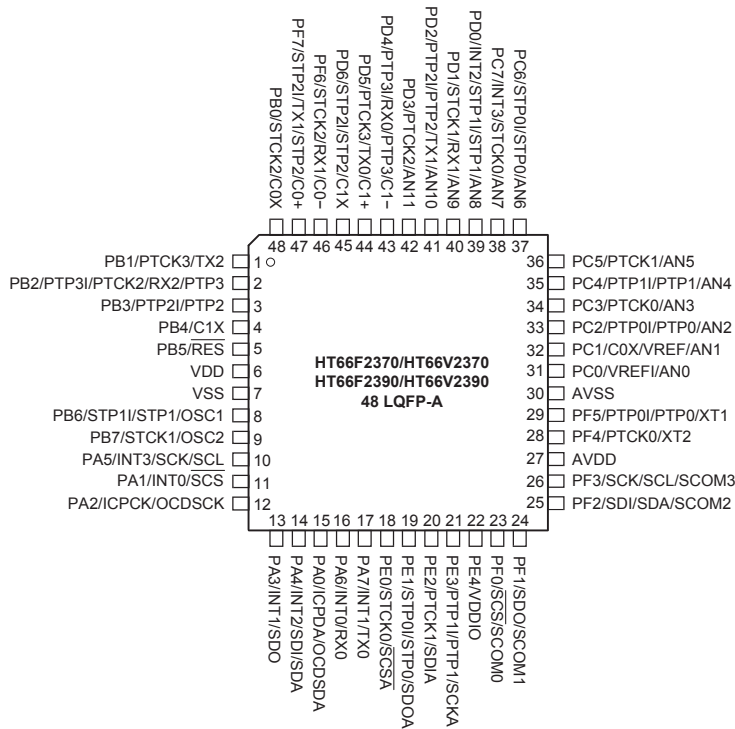
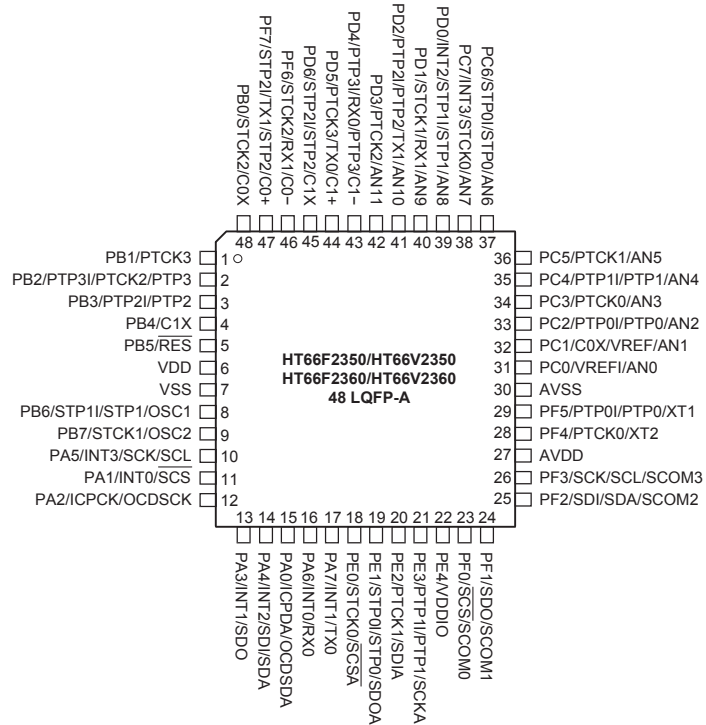

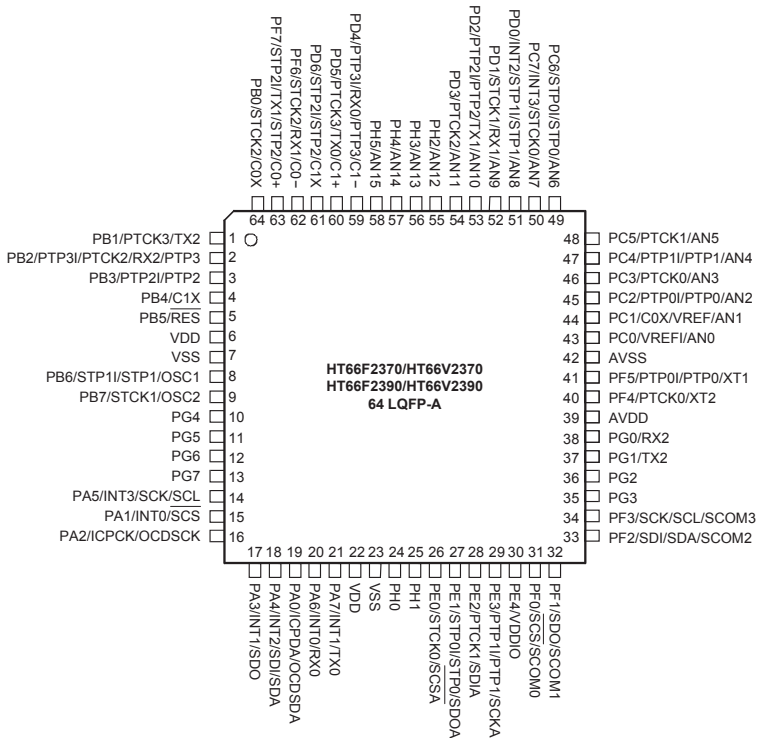
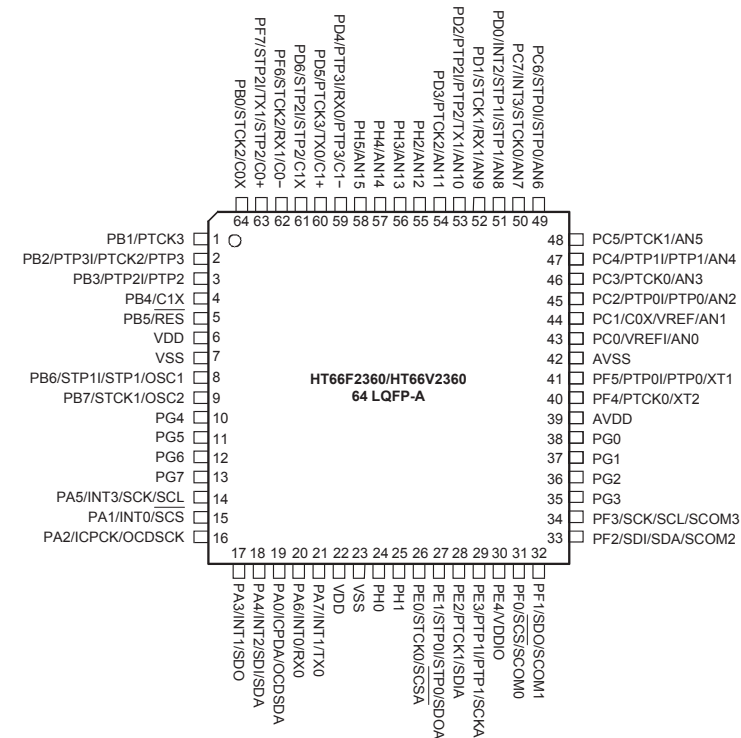

Note: The OCDSDA and OCDSCK pins are the OCDS dedicated pins and only available for the HT66V23x0 device which is the OCDS EV chip for the HT66F23x0 device.

## Pin Descriptions

With the exception of the power pins, all pins on these devices can be referenced by their Port name, e.g. PA0, PA1 etc, which refer to the digital I/O function of the pins. However these Port pins are also shared with other function such as the Analog to Digital Converter, Timer Module pins, etc. The function of each pin is listed in the following table, however the details behind how each pin is configured is contained in other sections of the datasheet.

**HT66F2350/HT66F2360**

| Pad Name                          | Function                | OPT                            | I/T | O/T  | Description  |
|-----------------------------------|-------------------------|--------------------------------|-----|------|--|
| PA0/ICPDA/<br>OCDSDA              | PA0                     | PAWU<br>PAPU<br>PAS0           | ST  | CMOS | General purpose I/O. Register enabled pull-up and wake-up. |
|                                   | ICPDA                   | —                              | ST  | CMOS | ICP Data/Address pin                                       |
|                                   | OCDSDA                  | —                              | ST  | CMOS | OCDS Data/Address pin, for EV chip only.                   |
| PA1/INT0/ $\overline{\text{SCS}}$ | PA1                     | PAWU<br>PAPU<br>PAS0           | ST  | CMOS | General purpose I/O. Register enabled pull-up and wake-up. |
|                                   | INT0                    | PAS0<br>INTEG<br>INTC0<br>IFS2 | ST  | —    | External Interrupt 0                                       |
|                                   | $\overline{\text{SCS}}$ | PAS0<br>IFS2                   | ST  | CMOS | SPI slave select   |
| PA2/ICPCK/<br>OCDSCK              | PA2                     | PAWU<br>PAPU<br>PAS0           | ST  | CMOS | General purpose I/O. Register enabled pull-up and wake-up. |
|                                   | ICPCK                   | —                              | ST  | CMOS | ICP Clock pin  |
|                                   | OCDSCK                  | —                              | ST  | —    | OCDS Clock pin, for EV chip only.                          |
| PA3/INT1/SDO                      | PA3                     | PAWU<br>PAPU<br>PAS0           | ST  | CMOS | General purpose I/O. Register enabled pull-up and wake-up. |
|                                   | INT1                    | PAS0<br>INTEG<br>INTC0<br>IFS2 | ST  | —    | External Interrupt 1                                       |
|                                   | SDO                     | PAS0                           | —   | CMOS | SPI data output  |
| PA4/INT2/SDI/SDA                  | PA4                     | PAWU<br>PAPU<br>PAS1           | ST  | CMOS | General purpose I/O. Register enabled pull-up and wake-up. |
|                                   | INT2                    | PAS1<br>INTEG<br>INTC3<br>IFS2 | ST  | —    | External Interrupt 2                                       |
|                                   | SDI                     | PAS1<br>IFS2                   | ST  | —    | SPI data input   |
|                                   | SDA                     | PAS1<br>IFS2                   | ST  | NMOS | I <sup>2</sup> C data line                                 |

| Pad Name                 | Function | OPT                            | I/T | O/T  | Description  |
|--------------------------|----------|--------------------------------|-----|------|--|
| PA5/INT3/SCK/SCL         | PA5      | PAWU<br>PAPU<br>PAS1           | ST  | CMOS | General purpose I/O. Register enabled pull-up and wake-up. |
|                          | INT3     | PAS1<br>INTEG<br>INTC3<br>IFS2 | ST  | —    | External Interrupt 3                                       |
|                          | SCK      | PAS1<br>IFS2                   | ST  | CMOS | SPI serial clock   |
|                          | SCL      | PAS1<br>IFS2                   | ST  | NMOS | I <sup>2</sup> C clock line                                |
| PA6/INT0/RX0             | PA6      | PAWU<br>PAPU<br>PAS1           | ST  | CMOS | General purpose I/O. Register enabled pull-up and wake-up. |
|                          | INT0     | PAS1<br>INTEG<br>INTC0<br>IFS2 | ST  | —    | External Interrupt 0                                       |
|                          | RX0      | PAS1<br>IFS3                   | ST  | —    | UART0 RX serial data input                                 |
| PA7/INT1/TX0             | PA7      | PAWU<br>PAPU<br>PAS1           | ST  | CMOS | General purpose I/O. Register enabled pull-up and wake-up. |
|                          | INT1     | PAS1<br>INTEG<br>INTC0<br>IFS2 | ST  | —    | External Interrupt 1                                       |
|                          | TX0      | PAS1                           | —   | CMOS | UART0 TX serial data output                                |
| PB0/STCK2/C0X            | PB0      | PBPU<br>PBS0                   | ST  | CMOS | General purpose I/O. Register enabled pull-up.             |
|                          | STCK2    | PBS0<br>IFS0                   | ST  | —    | STM2 clock input   |
|                          | C0X      | PBS0                           | —   | CMOS | Comparator 0 output  |
| PB1/PTCK3                | PB1      | PBPU<br>PBS0                   | ST  | CMOS | General purpose I/O. Register enabled pull-up.             |
|                          | PTCK3    | PBS0<br>IFS0                   | ST  | —    | PTM3 clock input   |
| PB2/PTP3I/PTCK2/<br>PTP3 | PB2      | PBPU<br>PBS0                   | ST  | CMOS | General purpose I/O. Register enabled pull-up.             |
|                          | PTP3I    | PBS0<br>IFS1                   | ST  | —    | PTM3 capture input   |
|                          | PTCK2    | PBS0<br>IFS0                   | ST  | —    | PTM2 clock input   |
|                          | PTP3     | PBS0                           | —   | CMOS | PTM3 output  |
| PB3/PTP2I/PTP2           | PB3      | PBPU<br>PBS0                   | ST  | CMOS | General purpose I/O. Register enabled pull-up.             |
|                          | PTP2I    | PBS0<br>IFS1                   | ST  | —    | PTM2 capture input   |
|                          | PTP2     | PBS0                           | —   | CMOS | PTM2 output  |
| PB4/C1X                  | PB4      | PBPU<br>PBS1                   | ST  | CMOS | General purpose I/O. Register enabled pull-up.             |
|                          | C1X      | PBS1                           | —   | CMOS | Comparator 1 output  |

| Pad Name                     | Function                | OPT                  | I/T | O/T  | Description                                    |
|------------------------------|-------------------------|----------------------|-----|------|--|
| PB5/ $\overline{\text{RES}}$ | PB5                     | PBPU<br>PBS1<br>RSTC | ST  | CMOS | General purpose I/O. Register enabled pull-up. |
|                              | $\overline{\text{RES}}$ | RSTC                 | ST  | —    | External reset input                           |
| PB6/STP11/STP1/<br>OSC1      | PB6                     | PBPU<br>PBS1         | ST  | CMOS | General purpose I/O. Register enabled pull-up. |
|                              | STP11                   | PBS1<br>IFS1         | ST  | —    | STM1 capture input                             |
|                              | STP1                    | PBS1                 | —   | CMOS | STM1 output                                    |
| PB7/STCK1/OSC2               | OSC1                    | PBS1                 | HXT | —    | HXT oscillator pin                             |
|                              | PB7                     | PBPU<br>PBS1         | ST  | CMOS | General purpose I/O. Register enabled pull-up. |
|                              | STCK1                   | PBS1<br>IFS0         | ST  | —    | STM1 clock input                               |
| PC0/VREFI/AN0                | OSC2                    | PBS1                 | —   | HXT  | HXT oscillator pin                             |
|                              | PC0                     | PCPU<br>PCS0         | ST  | CMOS | General purpose I/O. Register enabled pull-up. |
|                              | VREFI                   | PCS0                 | AN  | —    | A/D Converter reference voltage input          |
| PC1/C0X/VREF/<br>AN1         | AN0                     | PCS0                 | AN  | —    | A/D Converter analog input                     |
|                              | PC1                     | PCPU<br>PCS0         | ST  | CMOS | General purpose I/O. Register enabled pull-up. |
|                              | C0X                     | PCS0                 | —   | CMOS | Comparator 0 output                            |
|                              | VREF                    | PCS0                 | AN  | —    | A/D Converter reference voltage input          |
| PC2/PTP01/PTP0/<br>AN2       | AN1                     | PCS0                 | AN  | —    | A/D Converter analog input                     |
|                              | PC2                     | PCPU<br>PCS0         | ST  | CMOS | General purpose I/O. Register enabled pull-up. |
|                              | PTP01                   | PCS0<br>IFS1         | ST  | —    | PTM0 capture input                             |
|                              | PTP0                    | PCS0                 | —   | CMOS | PTM0 output                                    |
| PC3/PTCK0/AN3                | AN2                     | PCS0                 | AN  | —    | A/D Converter analog input                     |
|                              | PC3                     | PCPU<br>PCS0         | ST  | CMOS | General purpose I/O. Register enabled pull-up. |
|                              | PTCK0                   | PCS0<br>IFS0         | ST  | —    | PTM0 clock input                               |
| PC4/PTP11/PTP1/<br>AN4       | AN3                     | PCS0                 | AN  | —    | A/D Converter analog input                     |
|                              | PC4                     | PCPU<br>PCS1         | ST  | CMOS | General purpose I/O. Register enabled pull-up. |
|                              | PTP11                   | PCS1<br>IFS1         | ST  | —    | PTM1 capture input                             |
|                              | PTP1                    | PCS1                 | —   | CMOS | PTM1 output                                    |
| PC5/PTCK1/AN5                | AN4                     | PCS1                 | AN  | —    | A/D Converter analog input                     |
|                              | PC5                     | PCPU<br>PCS1         | ST  | CMOS | General purpose I/O. Register enabled pull-up. |
|                              | PTCK1                   | PCS1<br>IFS0         | ST  | —    | PTM1 clock input                               |
| PC6/STP01/STP0/<br>AN6       | AN5                     | PCS1                 | AN  | —    | A/D Converter analog input                     |
|                              | PC6                     | PCPU<br>PCS1         | ST  | CMOS | General purpose I/O. Register enabled pull-up. |
|                              | STP01                   | PCS1<br>IFS1         | ST  | —    | STM0 capture input                             |
|                              | STP0                    | PCS1                 | —   | CMOS | STM0 output                                    |
|                              | AN6                     | PCS1                 | AN  | —    | A/D Converter analog input                     |

| Pad Name                   | Function | OPT                            | I/T | O/T  | Description                                    |
|----------------------------|----------|--------------------------------|-----|------|--|
| PC7/INT3/STCK0/<br>AN7     | PC7      | PCPU<br>PCS1                   | ST  | CMOS | General purpose I/O. Register enabled pull-up. |
|                            | INT3     | PCS1<br>INTEG<br>INTC3<br>IFS2 | ST  | —    | External Interrupt 3                           |
|                            | STCK0    | PCS1<br>IFS0                   | ST  | —    | STM0 clock input                               |
|                            | AN7      | PCS1                           | AN  | —    | A/D Converter analog input                     |
| PD0/INT2/STP1/<br>STP1/AN8 | PD0      | PDP<br>PDS0                    | ST  | CMOS | General purpose I/O. Register enabled pull-up. |
|                            | INT2     | PDS0<br>INTEG<br>INTC3<br>IFS2 | ST  | —    | External Interrupt 2                           |
|                            | STP1     | PDS0<br>IFS1                   | ST  | —    | STM1 capture input                             |
|                            | STP1     | PDS0                           | —   | CMOS | STM1 output                                    |
| PD1/STCK1/RX1/<br>AN9      | PD1      | PDP<br>PDS0                    | ST  | CMOS | General purpose I/O. Register enabled pull-up. |
|                            | STCK1    | PDS0<br>IFS0                   | ST  | —    | STM1 clock input                               |
|                            | RX1      | PDS0<br>IFS3                   | ST  | —    | UART1 RX serial data input                     |
|                            | AN9      | PDS0                           | AN  | —    | A/D Converter analog input                     |
| PD2/PTP2/PTP2/<br>TX1/AN10 | PD2      | PDP<br>PDS0                    | ST  | CMOS | General purpose I/O. Register enabled pull-up. |
|                            | PTP2     | PDS0<br>IFS1                   | ST  | —    | PTM2 capture input                             |
|                            | PTP2     | PDS0                           | —   | CMOS | PTM2 output                                    |
|                            | TX1      | PDS0                           | —   | CMOS | UART1 TX serial data output                    |
| PD3/PTCK2/AN11             | AN10     | PDS0                           | AN  | —    | A/D Converter analog input                     |
|                            | PD3      | PDP<br>PDS0                    | ST  | CMOS | General purpose I/O. Register enabled pull-up. |
|                            | PTCK2    | PDS0<br>IFS0                   | ST  | —    | PTM2 clock input                               |
| PD4/PTP3/PTP3/<br>RX0/C1-  | AN11     | PDS0                           | AN  | —    | A/D Converter analog input                     |
|                            | PD4      | PDP<br>PDS1                    | ST  | CMOS | General purpose I/O. Register enabled pull-up. |
|                            | PTP3     | PDS1<br>IFS1                   | ST  | —    | PTM3 capture input                             |
|                            | PTP3     | PDS1                           | —   | CMOS | PTM3 output                                    |
| PD5/PTCK3/TX0/<br>C1+      | RX0      | PDS1<br>IFS3                   | ST  | —    | UART0 RX serial data input                     |
|                            | C1-      | PDS1                           | —   | CMOS | Comparator 1 negative input                    |
|                            | PD5      | PDP<br>PDS1                    | ST  | CMOS | General purpose I/O. Register enabled pull-up. |
|                            | PTCK3    | PDS1<br>IFS0                   | ST  | —    | PTM3 clock input                               |
| C1+                        | TX0      | PDS1                           | —   | CMOS | UART0 TX serial data output                    |
|                            | C1+      | PDS1                           | —   | CMOS | Comparator 1 positive input                    |

| Pad Name                | Function    | OPT          | I/T | O/T  | Description                                    |
|-------------------------|-------------|--------------|-----|------|--|
| PD6/STP2I/STP2/<br>C1X  | PD6         | PDP<br>PDS1  | ST  | CMOS | General purpose I/O. Register enabled pull-up. |
|                         | STP2I       | PDS1<br>IFS1 | ST  | —    | STM2 capture input                             |
|                         | STP2        | PDS1         | —   | CMOS | STM2 output                                    |
|                         | C1X         | PDS1         | —   | CMOS | Comparator 1 output                            |
| PE0/STCK0/ <u>SCSA</u>  | PE0         | PEP<br>PES0  | ST  | CMOS | General purpose I/O. Register enabled pull-up. |
|                         | STCK0       | PES0<br>IFS0 | ST  | —    | STM0 clock input                               |
|                         | <u>SCSA</u> | PES0         | ST  | CMOS | SPIA slave select                              |
| PE1/STP0I/STP0/<br>SDOA | PE1         | PEP<br>PES0  | ST  | CMOS | General purpose I/O. Register enabled pull-up. |
|                         | STP0I       | PES0<br>IFS  | ST  | —    | STM0 capture input                             |
|                         | STP0        | PES0         | —   | CMOS | STM0 inverted output                           |
|                         | SDOA        | PES0         | —   | CMOS | SPIA data output                               |
| PE2/PTCK1/SDIA          | PE2         | PEP<br>PES0  | ST  | CMOS | General purpose I/O. Register enabled pull-up. |
|                         | PTCK1       | PES0<br>IFS0 | ST  | —    | PTM1 clock input                               |
|                         | SDIA        | PES0         | ST  | —    | SPIA data input                                |
| PE3/PTP1I/PTP1/<br>SCKA | PE3         | PEP<br>PES0  | ST  | CMOS | General purpose I/O. Register enabled pull-up. |
|                         | PTP1I       | PES0<br>IFS1 | ST  | —    | PTM1 capture input                             |
|                         | PTP1        | PES0         | —   | CMOS | PTM1 output                                    |
|                         | SCKA        | PES0         | ST  | CMOS | SPIA serial clock                              |
| PE4/VDDIO               | PE4         | PEP<br>PES1  | ST  | CMOS | General purpose I/O. Register enabled pull-up. |
|                         | VDDIO       | PES1<br>PMP  | PWR | —    | PE0~PE3 pin power for level shift              |
| PF0/ <u>SCS</u> /SCOM0  | PF0         | PFPU<br>PFS0 | ST  | CMOS | General purpose I/O. Register enabled pull-up. |
|                         | <u>SCS</u>  | PFS0<br>IFS2 | ST  | CMOS | SPI slave select                               |
|                         | SCOM0       | PFS0         | —   | CMOS | Software LCD COM output                        |
| PF1/SDO/SCOM1           | PF1         | PFPU<br>PFS0 | ST  | CMOS | General purpose I/O. Register enabled pull-up. |
|                         | SDO         | PFS0         | —   | CMOS | SPI data output                                |
|                         | SCOM1       | PFS0         | —   | CMOS | Software LCD COM output                        |
| PF2/SDI/SDA/<br>SCOM2   | PF2         | PFPU<br>PFS0 | ST  | CMOS | General purpose I/O. Register enabled pull-up. |
|                         | SDI         | PFS0<br>IFS2 | ST  | —    | SPI data input                                 |
|                         | SDA         | PFS0<br>IFS2 | ST  | NMOS | I <sup>2</sup> C data line                     |
|                         | SCOM2       | PFS0         | —   | CMOS | Software LCD COM output                        |

| Pad Name                   | Function | OPT           | I/T | O/T  | Description                                    |
|----------------------------|----------|---------------|-----|------|--|
| PF3/SCK/SCL/<br>SCOM3      | PF3      | PFFPU<br>PFS0 | ST  | CMOS | General purpose I/O. Register enabled pull-up. |
|                            | SCK      | PFS0<br>IFS2  | ST  | CMOS | SPI serial clock                               |
|                            | SCL      | PFS0<br>IFS2  | ST  | NMOS | I <sup>2</sup> C clock line                    |
|                            | SCOM3    | PFS0          | —   | CMOS | Software LCD COM output                        |
| PF4/PTCK0/XT2              | PF4      | PFFPU<br>PFS1 | ST  | CMOS | General purpose I/O. Register enabled pull-up. |
|                            | PTCK0    | PFS1<br>IFS0  | ST  | —    | PTM0 clock input                               |
|                            | XT2      | PFS1          | —   | LXT  | LXT oscillator pin                             |
| PF5/PTP0I/PTP0/<br>XT1     | PF5      | PFFPU<br>PFS1 | ST  | CMOS | General purpose I/O. Register enabled pull-up. |
|                            | PTP0I    | PFS1<br>IFS1  | ST  | —    | PTM0 capture input                             |
|                            | PTP0     | PFS1          | —   | CMOS | PTM0 output                                    |
|                            | XT1      | PFS1          | LXT | —    | LXT oscillator pin                             |
| PF6/STCK2/RX1/<br>C0-      | PF6      | PFFPU<br>PFS1 | ST  | CMOS | General purpose I/O. Register enabled pull-up. |
|                            | STCK2    | PFS1<br>IFS0  | ST  | —    | STM2 clock input                               |
|                            | RX1      | PFS1<br>IFS3  | ST  | —    | UART1 RX serial data input                     |
|                            | C0-      | PFS1          | —   | CMOS | Comparator 0 negative input                    |
| PF7/STP2I/STP2/<br>TX1/C0+ | PF7      | PFFPU<br>PFS1 | ST  | CMOS | General purpose I/O. Register enabled pull-up. |
|                            | STP2I    | PFS1<br>IFS1  | ST  | —    | STM2 capture input                             |
|                            | STP2     | PFS1          | —   | CMOS | STM2 output                                    |
|                            | TX1      | PFS1          | —   | CMOS | UART1 TX serial data output                    |
|                            | C0+      | PDS1          | —   | CMOS | Comparator 0 positive input                    |
| PG0~PG3                    | PGn      | PGPU<br>PGS0  | ST  | CMOS | General purpose I/O. Register enabled pull-up. |
| PG4~PG7                    | PGn      | PGPU<br>PGS1  | ST  | CMOS | General purpose I/O. Register enabled pull-up. |
| PH0~PH1                    | PHn      | PHPU<br>PHS0  | ST  | CMOS | General purpose I/O. Register enabled pull-up. |
| PH2/AN12                   | PH2      | PHPU<br>PHS0  | ST  | CMOS | General purpose I/O. Register enabled pull-up. |
|                            | AN12     | PHS0          | AN  | —    | A/D Converter analog input                     |
| PH3/AN13                   | PH3      | PHPU<br>PHS0  | ST  | CMOS | General purpose I/O. Register enabled pull-up. |
|                            | AN13     | PHS0          | AN  | —    | A/D Converter analog input                     |
| PH4/AN14                   | PH4      | PHPU<br>PHS1  | ST  | CMOS | General purpose I/O. Register enabled pull-up. |
|                            | AN14     | PHS1          | AN  | —    | A/D Converter analog input                     |
| PH5/AN15                   | PH5      | PHPU<br>PHS1  | ST  | CMOS | General purpose I/O. Register enabled pull-up. |
|                            | AN15     | PHS1          | AN  | —    | A/D Converter analog input                     |
| VDD                        | VDD      | —             | PWR | —    | Positive power supply                          |
| VSS                        | VSS      | —             | PWR | —    | Negative power supply, ground.                 |

| Pad Name | Function | OPT | I/T | O/T | Description                           |
|----------|----------|-----|-----|-----|---------------------------------------|
| AVDD     | AVDD     | —   | PWR | —   | Analog positive power supply          |
| AVSS     | AVSS     | —   | PWR | —   | Analog negative power supply, ground. |

Legend: I/T: Input type; O/T: Output type;  
 OPT: Optional by register option; CMOS: CMOS output;  
 NMOS: NMOS output; ST: Schmitt Trigger input;  
 AN: Analog signal; PWR: Power;  
 HXT: High frequency crystal oscillator; LXT: Low frequency crystal oscillator  
 Note: The Ports G and H are available for the HT66F2360 device.

**HT66F2370/HT66F2390**

| Pad Name                          | Function                | OPT                            | I/T | O/T  | Description  |
|-----------------------------------|-------------------------|--------------------------------|-----|------|--|
| PA0/ICPDA/<br>OCDSDA              | PA0                     | PAWU<br>PAPU<br>PAS0           | ST  | CMOS | General purpose I/O. Register enabled pull-up and wake-up. |
|                                   | ICPDA                   | —                              | ST  | CMOS | ICP Data/Address pin                                       |
|                                   | OCDSDA                  | —                              | ST  | CMOS | OCDS Data/Address pin, for EV chip only.                   |
| PA1/INT0/ $\overline{\text{SCS}}$ | PA1                     | PAWU<br>PAPU<br>PAS0           | ST  | CMOS | General purpose I/O. Register enabled pull-up and wake-up. |
|                                   | INT0                    | PAS0<br>INTEG<br>INTC0<br>IFS2 | ST  | —    | External Interrupt 0                                       |
|                                   | $\overline{\text{SCS}}$ | PAS0<br>IFS2                   | ST  | CMOS | SPI slave select   |
| PA2/ICPCK/<br>OCDSCK              | PA2                     | PAWU<br>PAPU<br>PAS0           | ST  | CMOS | General purpose I/O. Register enabled pull-up and wake-up. |
|                                   | ICPCK                   | —                              | ST  | CMOS | ICP Clock pin  |
|                                   | OCDSCK                  | —                              | ST  | —    | OCDS Clock pin, for EV chip only.                          |
| PA3/INT1/SDO                      | PA3                     | PAWU<br>PAPU<br>PAS0           | ST  | CMOS | General purpose I/O. Register enabled pull-up and wake-up. |
|                                   | INT1                    | PAS0<br>INTEG<br>INTC0<br>IFS2 | ST  | —    | External Interrupt 1                                       |
|                                   | SDO                     | PAS0                           | —   | CMOS | SPI data output  |
| PA4/INT2/SDI/SDA                  | PA4                     | PAWU<br>PAPU<br>PAS1           | ST  | CMOS | General purpose I/O. Register enabled pull-up and wake-up. |
|                                   | INT2                    | PAS1<br>INTEG<br>INTC3<br>IFS2 | ST  | —    | External Interrupt 2                                       |
|                                   | SDI                     | PAS1<br>IFS2                   | ST  | —    | SPI data input   |
|                                   | SDA                     | PAS1<br>IFS2                   | ST  | NMOS | I <sup>2</sup> C data line                                 |

| Pad Name                     | Function | OPT                            | I/T | O/T  | Description  |
|------------------------------|----------|--------------------------------|-----|------|--|
| PA5/INT3/SCK/SCL             | PA5      | PAWU<br>PAPU<br>PAS1           | ST  | CMOS | General purpose I/O. Register enabled pull-up and wake-up. |
|                              | INT3     | PAS1<br>INTEG<br>INTC3<br>IFS2 | ST  | —    | External Interrupt 3                                       |
|                              | SCK      | PAS1<br>IFS2                   | ST  | CMOS | SPI serial clock   |
|                              | SCL      | PAS1<br>IFS2                   | ST  | NMOS | I <sup>2</sup> C clock line                                |
| PA6/INT0/RX0                 | PA6      | PAWU<br>PAPU<br>PAS1           | ST  | CMOS | General purpose I/O. Register enabled pull-up and wake-up. |
|                              | INT0     | PAS1<br>INTEG<br>INTC0<br>IFS2 | ST  | —    | External Interrupt 0                                       |
|                              | RX0      | PAS1<br>IFS3                   | ST  | —    | UART0 RX serial data input                                 |
| PA7/INT1/TX0                 | PA7      | PAWU<br>PAPU<br>PAS1           | ST  | CMOS | General purpose I/O. Register enabled pull-up and wake-up. |
|                              | INT1     | PAS1<br>INTEG<br>INTC0<br>IFS2 | ST  | —    | External Interrupt 1                                       |
|                              | TX0      | PAS1                           | —   | CMOS | UART0 TX serial data output                                |
| PB0/STCK2/C0X                | PB0      | PBPU<br>PBS0                   | ST  | CMOS | General purpose I/O. Register enabled pull-up.             |
|                              | STCK2    | PBS0<br>IFS0                   | ST  | —    | STM2 clock input   |
|                              | C0X      | PBS0                           | —   | CMOS | Comparator 0 output  |
| PB1/PTCK3/TX2                | PB1      | PBPU<br>PBS0                   | ST  | CMOS | General purpose I/O. Register enabled pull-up.             |
|                              | PTCK3    | PBS0<br>IFS0                   | ST  | —    | PTM3 clock input   |
|                              | TX2      | PBS0                           | —   | CMOS | UART2 TX serial data output                                |
| PB2/PTP3I/PTCK2/<br>PTP3/RX2 | PB2      | PBPU<br>PBS0                   | ST  | CMOS | General purpose I/O. Register enabled pull-up.             |
|                              | PTP3I    | PBS0<br>IFS1                   | ST  | —    | PTM3 capture input   |
|                              | PTCK2    | PBS0<br>IFS0                   | ST  | —    | PTM2 clock input   |
|                              | PTP3     | PBS0                           | —   | CMOS | PTM3 output  |
|                              | RX2      | PBS0<br>IFS3                   | ST  | —    | UART2 RX serial data input                                 |
| PB3/PTP2I/PTP2               | PB3      | PBPU<br>PBS0                   | ST  | CMOS | General purpose I/O. Register enabled pull-up.             |
|                              | PTP2I    | PBS0<br>IFS1                   | ST  | —    | PTM2 capture input   |
|                              | PTP2     | PBS0                           | —   | CMOS | PTM2 output  |
| PB4/C1X                      | PB4      | PBPU<br>PBS1                   | ST  | CMOS | General purpose I/O. Register enabled pull-up.             |
|                              | C1X      | PBS1                           | —   | CMOS | Comparator 1 output  |

| Pad Name                     | Function                | OPT                  | I/T | O/T  | Description                                    |
|------------------------------|-------------------------|----------------------|-----|------|--|
| PB5/ $\overline{\text{RES}}$ | PB5                     | PBPU<br>PBS1<br>RSTC | ST  | CMOS | General purpose I/O. Register enabled pull-up. |
|                              | $\overline{\text{RES}}$ | RSTC                 | ST  | —    | External reset input                           |
| PB6/STP11/STP1/<br>OSC1      | PB6                     | PBPU<br>PBS1         | ST  | CMOS | General purpose I/O. Register enabled pull-up. |
|                              | STP11                   | PBS1<br>IFS1         | ST  | —    | STM1 capture input                             |
|                              | STP1                    | PBS1                 | —   | CMOS | STM1 output                                    |
| PB7/STCK1/OSC2               | OSC1                    | PBS1                 | HXT | —    | HXT oscillator pin                             |
|                              | PB7                     | PBPU<br>PBS1         | ST  | CMOS | General purpose I/O. Register enabled pull-up. |
|                              | STCK1                   | PBS1<br>IFS0         | ST  | —    | STM1 clock input                               |
| PC0/VREFI/AN0                | OSC2                    | PBS1                 | —   | HXT  | HXT oscillator pin                             |
|                              | PC0                     | PCPU<br>PCS0         | ST  | CMOS | General purpose I/O. Register enabled pull-up. |
|                              | VREFI                   | PCS0                 | AN  | —    | A/D Converter reference voltage input          |
| PC1/C0X/VREF/<br>AN1         | AN0                     | PCS0                 | AN  | —    | A/D Converter analog input                     |
|                              | PC1                     | PCPU<br>PCS0         | ST  | CMOS | General purpose I/O. Register enabled pull-up. |
|                              | C0X                     | PCS0                 | —   | CMOS | Comparator 0 output                            |
|                              | VREF                    | PCS0                 | AN  | —    | A/D Converter reference voltage input          |
| PC2/PTP01/PTP0/<br>AN2       | AN1                     | PCS0                 | AN  | —    | A/D Converter analog input                     |
|                              | PC2                     | PCPU<br>PCS0         | ST  | CMOS | General purpose I/O. Register enabled pull-up. |
|                              | PTP01                   | PCS0<br>IFS1         | ST  | —    | PTM0 capture input                             |
|                              | PTP0                    | PCS0                 | —   | CMOS | PTM0 output                                    |
| PC3/PTCK0/AN3                | AN2                     | PCS0                 | AN  | —    | A/D Converter analog input                     |
|                              | PC3                     | PCPU<br>PCS0         | ST  | CMOS | General purpose I/O. Register enabled pull-up. |
|                              | PTCK0                   | PCS0<br>IFS0         | ST  | —    | PTM0 clock input                               |
| PC4/PTP11/PTP1/<br>AN4       | AN3                     | PCS0                 | AN  | —    | A/D Converter analog input                     |
|                              | PC4                     | PCPU<br>PCS1         | ST  | CMOS | General purpose I/O. Register enabled pull-up. |
|                              | PTP11                   | PCS1<br>IFS1         | ST  | —    | PTM1 capture input                             |
|                              | PTP1                    | PCS1                 | —   | CMOS | PTM1 output                                    |
| PC5/PTCK1/AN5                | AN4                     | PCS1                 | AN  | —    | A/D Converter analog input                     |
|                              | PC5                     | PCPU<br>PCS1         | ST  | CMOS | General purpose I/O. Register enabled pull-up. |
|                              | PTCK1                   | PCS1<br>IFS0         | ST  | —    | PTM1 clock input                               |
| PC6/STP01/STP0/<br>AN6       | AN5                     | PCS1                 | AN  | —    | A/D Converter analog input                     |
|                              | PC6                     | PCPU<br>PCS1         | ST  | CMOS | General purpose I/O. Register enabled pull-up. |
|                              | STP01                   | PCS1<br>IFS1         | ST  | —    | STM0 capture input                             |
|                              | STP0                    | PCS1                 | —   | CMOS | STM0 output                                    |
|                              | AN6                     | PCS1                 | AN  | —    | A/D Converter analog input                     |

| Pad Name                   | Function | OPT                            | I/T | O/T  | Description                                    |
|----------------------------|----------|--------------------------------|-----|------|--|
| PC7/INT3/STCK0/<br>AN7     | PC7      | PCPU<br>PCS1                   | ST  | CMOS | General purpose I/O. Register enabled pull-up. |
|                            | INT3     | PCS1<br>INTEG<br>INTC3<br>IFS2 | ST  | —    | External Interrupt 3                           |
|                            | STCK0    | PCS1<br>IFS0                   | ST  | —    | STM0 clock input                               |
|                            | AN7      | PCS1                           | AN  | —    | A/D Converter analog input                     |
| PD0/INT2/STP1/<br>STP1/AN8 | PD0      | PDP<br>PDS0                    | ST  | CMOS | General purpose I/O. Register enabled pull-up. |
|                            | INT2     | PDS0<br>INTEG<br>INTC3<br>IFS2 | ST  | —    | External Interrupt 2                           |
|                            | STP1     | PDS0<br>IFS1                   | ST  | —    | STM1 capture input                             |
|                            | STP1     | PDS0                           | —   | CMOS | STM1 output                                    |
| PD1/STCK1/RX1/<br>AN9      | PD1      | PDP<br>PDS0                    | ST  | CMOS | General purpose I/O. Register enabled pull-up. |
|                            | STCK1    | PDS0<br>IFS0                   | ST  | —    | STM1 clock input                               |
|                            | RX1      | PDS0<br>IFS3                   | ST  | —    | UART1 RX serial data input                     |
|                            | AN9      | PDS0                           | AN  | —    | A/D Converter analog input                     |
| PD2/PTP2/PTP2/<br>TX1/AN10 | PD2      | PDP<br>PDS0                    | ST  | CMOS | General purpose I/O. Register enabled pull-up. |
|                            | PTP2     | PDS0<br>IFS1                   | ST  | —    | PTM2 capture input                             |
|                            | PTP2     | PDS0                           | —   | CMOS | PTM2 output                                    |
|                            | TX1      | PDS0                           | —   | CMOS | UART1 TX serial data output                    |
| PD3/PTCK2/AN11             | AN10     | PDS0                           | AN  | —    | A/D Converter analog input                     |
|                            | PD3      | PDP<br>PDS0                    | ST  | CMOS | General purpose I/O. Register enabled pull-up. |
|                            | PTCK2    | PDS0<br>IFS0                   | ST  | —    | PTM2 clock input                               |
| PD4/PTP3/PTP3/<br>RX0/C1-  | AN11     | PDS0                           | AN  | —    | A/D Converter analog input                     |
|                            | PD4      | PDP<br>PDS1                    | ST  | CMOS | General purpose I/O. Register enabled pull-up. |
|                            | PTP3     | PDS1<br>IFS1                   | ST  | —    | PTM3 capture input                             |
|                            | PTP3     | PDS1                           | —   | CMOS | PTM3 output                                    |
| PD5/PTCK3/TX0/<br>C1+      | RX0      | PDS1<br>IFS3                   | ST  | —    | UART0 RX serial data input                     |
|                            | C1-      | PDS1                           | —   | CMOS | Comparator 1 negative input                    |
|                            | PD5      | PDP<br>PDS1                    | ST  | CMOS | General purpose I/O. Register enabled pull-up. |
|                            | PTCK3    | PDS1<br>IFS0                   | ST  | —    | PTM3 clock input                               |
| C1+                        | TX0      | PDS1                           | —   | CMOS | UART0 TX serial data output                    |
|                            | C1+      | PDS1                           | —   | CMOS | Comparator 1 positive input                    |

| Pad Name                | Function    | OPT          | I/T | O/T  | Description                                    |
|-------------------------|-------------|--------------|-----|------|--|
| PD6/STP2I/STP2/<br>C1X  | PD6         | PDP<br>PDS1  | ST  | CMOS | General purpose I/O. Register enabled pull-up. |
|                         | STP2I       | PDS1<br>IFS1 | ST  | —    | STM2 capture input                             |
|                         | STP2        | PDS1         | —   | CMOS | STM2 output                                    |
|                         | C1X         | PDS1         | —   | CMOS | Comparator 1 output                            |
| PE0/STCK0/ <u>SCSA</u>  | PE0         | PEP<br>PES0  | ST  | CMOS | General purpose I/O. Register enabled pull-up. |
|                         | STCK0       | PES0<br>IFS0 | ST  | —    | STM0 clock input                               |
|                         | <u>SCSA</u> | PES0         | ST  | CMOS | SPIA slave select                              |
| PE1/STP0I/STP0/<br>SDOA | PE1         | PEP<br>PES0  | ST  | CMOS | General purpose I/O. Register enabled pull-up. |
|                         | STP0I       | PES0<br>IFS  | ST  | —    | STM0 capture input                             |
|                         | STP0        | PES0         | —   | CMOS | STM0 inverted output                           |
|                         | SDOA        | PES0         | —   | CMOS | SPIA data output                               |
| PE2/PTCK1/SDIA          | PE2         | PEP<br>PES0  | ST  | CMOS | General purpose I/O. Register enabled pull-up. |
|                         | PTCK1       | PES0<br>IFS0 | ST  | —    | PTM1 clock input                               |
|                         | SDIA        | PES0         | ST  | —    | SPIA data input                                |
| PE3/PTP1I/PTP1/<br>SCKA | PE3         | PEP<br>PES0  | ST  | CMOS | General purpose I/O. Register enabled pull-up. |
|                         | PTP1I       | PES0<br>IFS1 | ST  | —    | PTM1 capture input                             |
|                         | PTP1        | PES0         | —   | CMOS | PTM1 output                                    |
|                         | SCKA        | PES0         | ST  | CMOS | SPIA serial clock                              |
| PE4/VDDIO               | PE4         | PEP<br>PES1  | ST  | CMOS | General purpose I/O. Register enabled pull-up. |
|                         | VDDIO       | PES1<br>PMPS | PWR | —    | PE0~PE3 pin power for level shift              |
| PF0/ <u>SCS</u> /SCOM0  | PF0         | PFPU<br>PFS0 | ST  | CMOS | General purpose I/O. Register enabled pull-up. |
|                         | <u>SCS</u>  | PFS0<br>IFS2 | ST  | CMOS | SPI slave select                               |
|                         | SCOM0       | PFS0         | —   | CMOS | Software LCD COM output                        |
| PF1/SDO/SCOM1           | PF1         | PFPU<br>PFS0 | ST  | CMOS | General purpose I/O. Register enabled pull-up. |
|                         | SDO         | PFS0         | —   | CMOS | SPI data output                                |
|                         | SCOM1       | PFS0         | —   | CMOS | Software LCD COM output                        |
| PF2/SDI/SDA/<br>SCOM2   | PF2         | PFPU<br>PFS0 | ST  | CMOS | General purpose I/O. Register enabled pull-up. |
|                         | SDI         | PFS0<br>IFS2 | ST  | —    | SPI data input                                 |
|                         | SDA         | PFS0<br>IFS2 | ST  | NMOS | I <sup>2</sup> C data line                     |
|                         | SCOM2       | PFS0         | —   | CMOS | Software LCD COM output                        |

| Pad Name                   | Function | OPT           | I/T | O/T  | Description                                    |
|----------------------------|----------|---------------|-----|------|--|
| PF3/SCK/SCL/<br>SCOM3      | PF3      | PFFPU<br>PFS0 | ST  | CMOS | General purpose I/O. Register enabled pull-up. |
|                            | SCK      | PFS0<br>IFS2  | ST  | CMOS | SPI serial clock                               |
|                            | SCL      | PFS0<br>IFS2  | ST  | NMOS | I <sup>2</sup> C clock line                    |
|                            | SCOM3    | PFS0          | —   | CMOS | Software LCD COM output                        |
| PF4/PTCK0/XT2              | PF4      | PFFPU<br>PFS1 | ST  | CMOS | General purpose I/O. Register enabled pull-up. |
|                            | PTCK0    | PFS1<br>IFS0  | ST  | —    | PTM0 clock input                               |
|                            | XT2      | PFS1          | —   | LXT  | LXT oscillator pin                             |
| PF5/PTP0I/PTP0/<br>XT1     | PF5      | PFFPU<br>PFS1 | ST  | CMOS | General purpose I/O. Register enabled pull-up. |
|                            | PTP0I    | PFS1<br>IFS1  | ST  | —    | PTM0 capture input                             |
|                            | PTP0     | PFS1          | —   | CMOS | PTM0 output                                    |
|                            | XT1      | PFS1          | LXT | —    | LXT oscillator pin                             |
| PF6/STCK2/RX1/<br>C0-      | PF6      | PFFPU<br>PFS1 | ST  | CMOS | General purpose I/O. Register enabled pull-up. |
|                            | STCK2    | PFS1<br>IFS0  | ST  | —    | STM2 clock input                               |
|                            | RX1      | PFS1<br>IFS3  | ST  | —    | UART1 RX serial data input                     |
|                            | C0-      | PFS1          | —   | CMOS | Comparator 0 negative input                    |
| PF7/STP2I/STP2/<br>TX1/C0+ | PF7      | PFFPU<br>PFS1 | ST  | CMOS | General purpose I/O. Register enabled pull-up. |
|                            | STP2I    | PFS1<br>IFS1  | ST  | —    | STM2 capture input                             |
|                            | STP2     | PFS1          | —   | CMOS | STM2 output                                    |
|                            | TX1      | PFS1          | —   | CMOS | UART1 TX serial data output                    |
|                            | C0+      | PDS1          | —   | CMOS | Comparator 0 positive input                    |
| PG0/RX2                    | PG0      | PGPU<br>PGS0  | ST  | CMOS | General purpose I/O. Register enabled pull-up. |
|                            | RX2      | PGS0<br>IFS3  | ST  | —    | UART2 RX serial data input                     |
| PG1/TX2                    | PG1      | PGPU<br>PGS0  | ST  | CMOS | General purpose I/O. Register enabled pull-up. |
|                            | TX2      | PGS0          | —   | CMOS | UART2 TX serial data output                    |
| PG2~PG3                    | PGn      | PGPU<br>PGS0  | ST  | CMOS | General purpose I/O. Register enabled pull-up. |
| PG4~PG7                    | PGn      | PGPU<br>PGS1  | ST  | CMOS | General purpose I/O. Register enabled pull-up. |
| PH0~PH1                    | PHn      | PHPU<br>PHS0  | ST  | CMOS | General purpose I/O. Register enabled pull-up. |
| PH2/AN12                   | PH2      | PHPU<br>PHS0  | ST  | CMOS | General purpose I/O. Register enabled pull-up. |
|                            | AN12     | PHS0          | AN  | —    | A/D Converter analog input                     |
| PH3/AN13                   | PH3      | PHPU<br>PHS0  | ST  | CMOS | General purpose I/O. Register enabled pull-up. |
|                            | AN13     | PHS0          | AN  | —    | A/D Converter analog input                     |

| Pad Name | Function | OPT          | I/T | O/T  | Description                                    |
|----------|----------|--------------|-----|------|--|
| PH4/AN14 | PH4      | PHPU<br>PHS1 | ST  | CMOS | General purpose I/O. Register enabled pull-up. |
|          | AN14     | PHS1         | AN  | —    | A/D Converter analog input                     |
| PH5/AN15 | PH5      | PHPU<br>PHS1 | ST  | CMOS | General purpose I/O. Register enabled pull-up. |
|          | AN15     | PHS1         | AN  | —    | A/D Converter analog input                     |
| VDD      | VDD      | —            | PWR | —    | Positive power supply                          |
| VSS      | VSS      | —            | PWR | —    | Negative power supply, ground.                 |
| AVDD     | AVDD     | —            | PWR | —    | Analog positive power supply                   |
| AVSS     | AVSS     | —            | PWR | —    | Analog negative power supply, ground.          |

Legend: I/T: Input type;

OPT: Optional by register option;

NMOS: NMOS output;

AN: Analog signal;

HXT: High frequency crystal oscillator;

O/T: Output type;

CMOS: CMOS output;

ST: Schmitt Trigger input;

PWR: Power;

LXT: Low frequency crystal oscillator

## Absolute Maximum Ratings

|                               |                                  |
|-------------------------------|----------------------------------|
| Supply Voltage .....          | $V_{SS}-0.3V$ to $V_{SS}+6.0V$   |
| Input Voltage .....           | $V_{SS}-0.3V$ to $V_{DD}+0.3V$   |
| Storage Temperature.....      | $-50^{\circ}C$ to $125^{\circ}C$ |
| Operating Temperature.....    | $-40^{\circ}C$ to $85^{\circ}C$  |
| $I_{OL}$ Total .....          | 80mA                             |
| $I_{OH}$ Total .....          | -80mA                            |
| Total Power Dissipation ..... | 500mW                            |

Note: These are stress ratings only. Stresses exceeding the range specified under "Absolute Maximum Ratings" may cause substantial damage to these devices. Functional operation of these devices at other conditions beyond those listed in the specification is not implied and prolonged exposure to extreme conditions may affect devices reliability.

## D.C. Characteristics

For data in the following tables, note that factors such as oscillator type, operating voltage, operating frequency, pin load conditions, temperature and program instruction type, etc., can all exert an influence on the measured values.

### Operating Voltage Characteristics

$T_a = -40^{\circ}C$  to  $85^{\circ}C$

| Symbol                   | Parameter                | Test Conditions | Min. | Typ. | Max. | Unit |
|--------------------------|--------------------------|-----------------|------|------|------|------|
| $V_{DD}$                 | Operating Voltage – HXT  | $f_{SYS}=8MHz$  | 2.2  | —    | 5.5  | V    |
|                          |                          | $f_{SYS}=12MHz$ | 2.7  | —    | 5.5  |      |
|                          |                          | $f_{SYS}=16MHz$ | 3.3  | —    | 5.5  |      |
|                          | Operating Voltage – HIRC | $f_{SYS}=8MHz$  | 2.2  | —    | 5.5  | V    |
|                          |                          | $f_{SYS}=12MHz$ | 2.7  | —    | 5.5  |      |
|                          |                          | $f_{SYS}=16MHz$ | 3.3  | —    | 5.5  |      |
| Operating Voltage – LXT  | $f_{SYS}=32768Hz$        | 2.2             | —    | 5.5  | V    |      |
| Operating Voltage – LIRC | $f_{SYS}=32kHz$          | 2.2             | —    | 5.5  | V    |      |

### Standby Current Characteristics

Ta=25°C

| Symbol           | Standby Mode      | Test Conditions |  | Min. | Typ. | Max. | Max.<br>85°C | Unit |
|------------------|-------------------|-----------------|--|------|------|------|--------------|------|
|                  |                   | V <sub>DD</sub> | Conditions                                   |      |      |      |              |      |
| I <sub>STB</sub> | SLEEP Mode        | 2.2V            | WDT off                                      | —    | 0.11 | 0.15 | 2.00         | μA   |
|                  |                   | 3V              |  | —    | 0.11 | 0.15 | 2.00         |      |
|                  |                   | 5V              |  | —    | 0.18 | 0.38 | 2.90         |      |
|                  |                   | 2.2V            | WDT on                                       | —    | 1.2  | 2.4  | 2.9          | μA   |
|                  |                   | 3V              |  | —    | —    | 3.0  | 3.6          |      |
|                  |                   | 5V              |  | —    | —    | 5.0  | 6.0          |      |
|                  | IDLE0 Mode        | 2.2V            | f <sub>SUB</sub> on                          | —    | 2.4  | 4.0  | 4.8          | μA   |
|                  |                   | 3V              |  | —    | 3.0  | 5.0  | 6.0          |      |
|                  |                   | 5V              |  | —    | 5.0  | 10   | 12           |      |
|                  | IDLE1 Mode – HIRC | 2.2V            | f <sub>SUB</sub> on, f <sub>SYS</sub> =8MHz  | —    | 0.3  | 0.6  | 0.8          | mA   |
|                  |                   | 3V              |  | —    | 0.5  | 1.0  | 1.8          |      |
|                  |                   | 5V              |  | —    | 1.0  | 2.0  | 2.2          |      |
|                  |                   | 2.7V            | f <sub>SUB</sub> on, f <sub>SYS</sub> =12MHz | —    | 0.4  | 0.8  | 1.0          | mA   |
|                  |                   | 3V              |  | —    | 0.6  | 1.2  | 1.4          |      |
|                  |                   | 5V              |  | —    | 1.2  | 2.4  | 2.6          |      |
|                  | IDLE1 Mode – HXT  | 3.3V            | f <sub>SUB</sub> on, f <sub>SYS</sub> =16MHz | —    | 1.5  | 3.0  | 3.2          | mA   |
|                  |                   | 5V              |  | —    | 2.0  | 4.0  | 4.2          |      |
|                  | IDLE1 Mode – HXT  | 2.2V            | f <sub>SUB</sub> on, f <sub>SYS</sub> =8MHz  | —    | 0.3  | 0.6  | 0.8          | mA   |
|                  |                   | 3V              |  | —    | 0.5  | 1.0  | 1.2          |      |
|                  |                   | 5V              |  | —    | 1.0  | 2.0  | 2.2          |      |
|                  |                   | 2.7V            | f <sub>SUB</sub> on, f <sub>SYS</sub> =12MHz | —    | 0.4  | 0.8  | 1.0          | mA   |
| 3V               |                   | —               |  | 0.6  | 1.2  | 1.4  |              |      |
| 5V               |                   | —               |  | 1.2  | 2.4  | 2.6  |              |      |
| IDLE1 Mode – HXT |                   | 3.3V            | f <sub>SUB</sub> on, f <sub>SYS</sub> =16MHz | —    | 1.5  | 3.0  | 3.2          | mA   |
|                  |                   | 5V              |  | —    | 2.0  | 4.0  | 4.2          |      |

Note: When using the characteristic table data, the following notes should be taken into consideration:

1. Any digital inputs are setup in a non floating condition.
2. All measurements are taken under conditions of no load and with all peripherals in an off state.
3. There are no DC current paths.
4. All Standby Current values are taken after a HALT instruction execution thus stopping all instruction execution.

### Operating Current Characteristics

Ta=25°C

| Symbol          | Operating Mode   | Test Conditions         |                           | Min.                   | Typ. | Max. | Unit |
|-----------------|------------------|-------------------------|---------------------------|------------------------|------|------|------|
|                 |                  | V <sub>DD</sub>         | Conditions                |                        |      |      |      |
| I <sub>DD</sub> | SLOW Mode – LXT  | 2.2V                    | f <sub>sys</sub> =32768Hz | —                      | 8    | 16   | μA   |
|                 |                  | 3V                      |                           | —                      | 10   | 20   |      |
|                 |                  | 5V                      |                           | —                      | 30   | 50   |      |
|                 | SLOW Mode – LIRC | 2.2V                    | f <sub>sys</sub> =32kHz   | —                      | 8    | 16   | μA   |
|                 |                  | 3V                      |                           | —                      | 10   | 20   |      |
|                 |                  | 5V                      |                           | —                      | 30   | 50   |      |
|                 | FAST Mode – HIRC | 2.2V                    | f <sub>sys</sub> =8MHz    | —                      | 0.8  | 1.2  | mA   |
|                 |                  | 3V                      |                           | —                      | 1.0  | 1.5  |      |
|                 |                  | 5V                      |                           | —                      | 2.0  | 3.0  |      |
|                 |                  | 2.7V                    | f <sub>sys</sub> =12MHz   | —                      | 1.2  | 2.2  | mA   |
|                 |                  | 3V                      |                           | —                      | 1.5  | 2.75 |      |
|                 |                  | 5V                      |                           | —                      | 3.0  | 4.5  |      |
|                 | FAST Mode – HXT  | 2.2V                    | f <sub>sys</sub> =8MHz    | —                      | 0.8  | 1.2  | mA   |
|                 |                  | 3V                      |                           | —                      | 1.0  | 1.5  |      |
|                 |                  | 5V                      |                           | —                      | 2.0  | 3.0  |      |
|                 |                  | 2.7V                    | f <sub>sys</sub> =12MHz   | —                      | 1.2  | 2.2  | mA   |
|                 | 3V               | —                       |                           | 1.5                    | 2.75 |      |      |
|                 | 5V               | —                       |                           | 3.0                    | 4.5  |      |      |
|                 | FAST Mode – HXT  | 3.3V                    | f <sub>sys</sub> =16MHz   | —                      | 3.2  | 4.8  | mA   |
|                 |                  | 5V                      |                           | —                      | 4.5  | 7.0  |      |
|                 |                  | FAST Mode – HXT         | 2.2V                      | f <sub>sys</sub> =8MHz | —    | 0.8  | 1.2  |
| 3V              |                  |                         | —                         |                        | 1.0  | 1.5  |      |
| FAST Mode – HXT | 2.7V             | f <sub>sys</sub> =12MHz | —                         | 1.2                    | 2.2  | mA   |      |
|                 | 3V               |                         | —                         | 1.5                    | 2.75 |      |      |
| FAST Mode – HXT | 3.3V             | f <sub>sys</sub> =16MHz | —                         | 3.2                    | 4.8  | mA   |      |
|                 | 5V               |                         | —                         | 4.5                    | 7.0  |      |      |

Note: When using the characteristic table data, the following notes should be taken into consideration:

1. Any digital inputs are setup in a non floating condition.
2. All measurements are taken under conditions of no load and with all peripherals in an off state.
3. There are no DC current paths.
4. All Operating Current values are measured using a continuous NOP instruction program loop.

## A.C. Characteristics

For data in the following tables, note that factors such as oscillator type, operating voltage, operating frequency and temperature etc., can all exert an influence on the measured values.

### High Speed Internal Oscillator – HIRC – Frequency Accuracy

During the program writing operation the writer will trim the HIRC oscillator at a user selected HIRC frequency and user selected voltage of either 3V or 5V.

8/12/16MHz

| Symbol            | Parameter                           | Test Conditions |              | Min   | Typ | Max   | Unit |
|-------------------|-------------------------------------|-----------------|--------------|-------|-----|-------|------|
|                   |                                     | V <sub>DD</sub> | Temp.        |       |     |       |      |
| f <sub>HIRC</sub> | 8MHz Writer Trimmed HIRC Frequency  | 3V/5V           | 25°C         | -1%   | 8   | +1%   | MHz  |
|                   |                                     |                 | -40°C ~ 85°C | -2%   | 8   | +2%   |      |
|                   |                                     | 2.2V~5.5V       | 25°C         | -2.5% | 8   | +2.5% |      |
|                   |                                     |                 | -40°C ~ 85°C | -3%   | 8   | +3%   |      |
|                   | 12MHz Writer Trimmed HIRC Frequency | 3V/5V           | 25°C         | -1%   | 12  | +1%   | MHz  |
|                   |                                     |                 | -40°C ~ 85°C | -2%   | 12  | +2%   |      |
|                   |                                     | 2.7V~5.5V       | 25°C         | -2.5% | 12  | +2.5% |      |
|                   |                                     |                 | -40°C ~ 85°C | -3%   | 12  | +3%   |      |
|                   | 16MHz Writer Trimmed HIRC Frequency | 5V              | 25°C         | -1%   | 16  | +1%   | MHz  |
|                   |                                     |                 | -40°C ~ 85°C | -2%   | 16  | +2%   |      |
|                   |                                     | 3.3V~5.5V       | 25°C         | -2.5% | 16  | +2.5% |      |
|                   |                                     |                 | -40°C ~ 85°C | -3%   | 16  | +3%   |      |

- Note: 1. The 3V/5V values for V<sub>DD</sub> are provided as these are the two selectable fixed voltages at which the HIRC frequency is trimmed by the writer.
2. The row below the 3V/5V trim voltage row is provided to show the values for the full V<sub>DD</sub> range operating voltage. It is recommended that the trim voltage is fixed at 3V for application voltage ranges from 2.2V to 3.3V and fixed at 5V for application voltage ranges from 3.3V to 5.5V.
3. The minimum and maximum tolerance values provided in the table are only for the frequency at which the writer trims the HIRC oscillator. After trimming at this chosen specific frequency any change in HIRC oscillator frequency using the oscillator register control bits by the application program will give a frequency tolerance to within ±20%.

### Low Speed Internal Oscillator Characteristics – LIRC

T<sub>a</sub>=25°C, unless otherwise specified

| Symbol             | Parameter            | Test Conditions |              | Min. | Typ. | Max. | Unit |
|--------------------|----------------------|-----------------|--------------|------|------|------|------|
|                    |                      | V <sub>DD</sub> | Temp.        |      |      |      |      |
| f <sub>LIRC</sub>  | Oscillator Frequency | 2.2V~5.5V       | 25°C         | -2%  | 32   | +2%  | kHz  |
|                    |                      |                 | -40°C ~ 85°C | -10% | 32   | +10% |      |
| t <sub>START</sub> | Start Up Time        | —               | —            | —    | —    | 100  | µs   |

### Low Speed Crystal Oscillator Characteristics – LXT

T<sub>a</sub>=25°C

| Symbol             | Parameter             | Test Conditions |   | Min.  | Typ.   | Max. | Unit |
|--------------------|-----------------------|-----------------|---|-------|--------|------|------|
|                    |                       | V <sub>DD</sub> | Conditions                                    |       |        |      |      |
| f <sub>LXT</sub>   | Oscillator Frequency  | 2.2~5.5V        | f <sub>sys</sub> =f <sub>LXT</sub> =32.768kHz | -10%  | 32.768 | +10% | kHz  |
| Duty Cycle         | Duty Cycle            | —               | —   | 45    | 50     | 55   | %    |
| t <sub>START</sub> | Start Up Time         | —               | —   | —     | —      | 500  | ms   |
| R <sub>NEG</sub>   | Negative Resistance * | 2.2V            | —   | 3*ESR | —      | —    | Ω    |

Note: \*: C<sub>1</sub>, C<sub>2</sub> and R<sub>p</sub> are external components. C<sub>1</sub>=C<sub>2</sub>=10pF. R<sub>p</sub>=10MΩ. C<sub>L</sub>=7pF, ESR=30kΩ.

### Operating Frequency Characteristic Curves

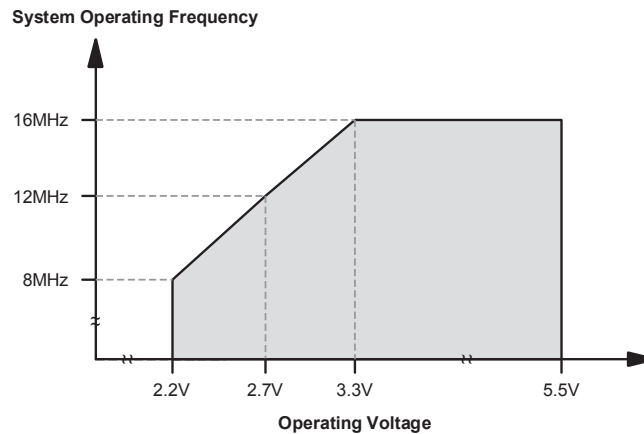

### System Start Up Time Characteristics

Ta=-40°C ~ 85°C

| Symbol   | Parameter   | Test Conditions  | Min. | Typ. | Max.              | Unit              |
|--|---|--|------|------|-------------------|-------------------|
| t <sub>SST</sub>   | System Start-up Time<br>Wake-up from Condition where f <sub>sys</sub> is off      | f <sub>sys</sub> =f <sub>H</sub> ~ f <sub>H</sub> /64, f <sub>H</sub> =f <sub>HXT</sub>                      | —    | 128  | —                 | t <sub>HXT</sub>  |
|  |   | f <sub>sys</sub> =f <sub>H</sub> ~ f <sub>H</sub> /64, f <sub>H</sub> =f <sub>HIRC</sub>                     | —    | 16   | —                 | t <sub>HIRC</sub> |
|  |   | f <sub>sys</sub> =f <sub>SUB</sub> =f <sub>LXT</sub>   | —    | 1024 | —                 | t <sub>LXT</sub>  |
|  |   | f <sub>sys</sub> =f <sub>SUB</sub> =f <sub>LIRC</sub>  | —    | 2    | —                 | t <sub>LIRC</sub> |
|  | System Start-up Time<br>Wake-up from Condition where f <sub>sys</sub> is on.      | f <sub>sys</sub> =f <sub>H</sub> ~ f <sub>H</sub> /64, f <sub>H</sub> =f <sub>HXT</sub> or f <sub>HIRC</sub> | —    | 2    | —                 | t <sub>H</sub>    |
|  |   | f <sub>sys</sub> =f <sub>SUB</sub> =f <sub>LXT</sub> or f <sub>LIRC</sub>                                    | —    | 2    | —                 | t <sub>SUB</sub>  |
| System Speed Switch Time<br>FAST to Slow Mode or SLOW to FAST Mode | f <sub>HXT</sub> switches from off → on   | —  | 1024 | —    | t <sub>HXT</sub>  |                   |
|  | f <sub>HIRC</sub> switches from off → on  | —  | 16   | —    | t <sub>HIRC</sub> |                   |
|  | f <sub>LXT</sub> switches from off → on   | —  | 1024 | —    | t <sub>LXT</sub>  |                   |
| t <sub>RSTD</sub>  | System Reset Delay Time<br>Reset Source from Power-on Reset or LVR Hardware Reset | RR <sub>POR</sub> =5V/ms   | 42   | 48   | 54                | ms                |
|  | System Reset Delay Time<br>LVRC/WDT/RSTC Software Reset                           | —  |      |      |                   |                   |
|  | System Reset Delay Time<br>Reset Source from WDT Overflow or Reset pin reset      | —  | 14   | 16   | 18                |                   |

Note: 1. For the System Start-up time values, whether f<sub>sys</sub> is on or off depends upon the mode type and the chosen f<sub>sys</sub> system oscillator. Details are provided in the System Operating Modes section.

- The time units, shown by the symbols t<sub>HXT</sub>, t<sub>HIRC</sub> etc. are the inverse of the corresponding frequency values as provided in the frequency tables. For example t<sub>HIRC</sub>=1/f<sub>HIRC</sub>, t<sub>sys</sub>=1/f<sub>sys</sub> etc.
- If the LIRC is used as the system clock and if it is off when in the SLEEP Mode, then an additional LIRC start up time, t<sub>START</sub>, as provided in the LIRC frequency table, must be added to the t<sub>SST</sub> time in the table above.
- The System Speed Switch Time is effectively the time taken for the newly activated oscillator to start up.

## Input/Output Characteristics

Ta=25°C

| Symbol            | Parameter   | Test Conditions |   | Min.               | Typ.  | Max.               | Unit |
|-------------------|---|-----------------|---|--------------------|-------|--------------------|------|
|                   |   | V <sub>DD</sub> | Conditions  |                    |       |                    |      |
| V <sub>IL</sub>   | Input Low Voltage for I/O Ports or Input Pins   | 5V              | —   | 0                  | —     | 1.5                | V    |
|                   |   | —               | —   | 0                  | —     | 0.2V <sub>DD</sub> |      |
| V <sub>IH</sub>   | Input High Voltage for I/O Ports or Input Pins  | 5V              | —   | 3.5                | —     | 5.0                | V    |
|                   |   | —               | —   | 0.8V <sub>DD</sub> | —     | V <sub>DD</sub>    |      |
| I <sub>OL</sub>   | Sink Current for I/O Pins   | 3V              | V <sub>OL</sub> =0.1V <sub>DD</sub>   | 16                 | 32    | —                  | mA   |
|                   |   | 5V              |   | 32                 | 64    | —                  |      |
| I <sub>OH</sub>   | Source Current for I/O Pins   | 3V              | V <sub>OH</sub> =0.9V <sub>DD</sub> , SLEDCn[m+1:m]=00, n=A, B, C, D or E, m=0, 2, 4 or 6 | -1.0               | -2.0  | —                  | mA   |
|                   |   | 5V              |   | -2.0               | -4.0  | —                  |      |
|                   |   | 3V              | V <sub>OH</sub> =0.9V <sub>DD</sub> , SLEDCn[m+1:m]=01, n=A, B, C, D or E, m=0, 2, 4 or 6 | -1.75              | -3.5  | —                  |      |
|                   |   | 5V              |   | -3.5               | -7.0  | —                  |      |
|                   |   | 3V              | V <sub>OH</sub> =0.9V <sub>DD</sub> , SLEDCn[m+1:m]=10, n=A, B, C, D or E, m=0, 2, 4 or 6 | -2.5               | -5.0  | —                  |      |
|                   |   | 5V              |   | -5.0               | -10.0 | —                  |      |
| 3V                | V <sub>OH</sub> =0.9V <sub>DD</sub> , SLEDCn[m+1:m]=11, n=A, B, C, D or E, m=0, 2, 4 or 6 | -5.5            | -11.0   | —                  |       |                    |      |
| 5V                |   | -11.0           | -22.0   | —                  |       |                    |      |
| R <sub>PH</sub>   | Pull-high Resistance for I/O Ports <sup>(Note)</sup>                                      | 3V              | —   | 20                 | 60    | 100                | kΩ   |
|                   |   | 5V              | —   | 10                 | 30    | 50                 |      |
| I <sub>LEAK</sub> | Input leakage current   | 5V              | V <sub>IN</sub> =V <sub>DD</sub> or V <sub>IN</sub> =V <sub>SS</sub>                      | —                  | —     | ±1                 | μA   |
| t <sub>TPI</sub>  | TM Capture Input Minimum Pulse Width  | —               | —   | 0.3                | —     | —                  | μs   |
| t <sub>TCK</sub>  | TM Clock Input Minimum Pulse Width  | —               | —   | 0.3                | —     | —                  | μs   |
| t <sub>INT</sub>  | Interrupt Input Pin Minimum Pulse Width   | —               | —   | 10                 | —     | —                  | μs   |

Note: The R<sub>PH</sub> internal pull high resistance value is calculated by connecting to ground and enabling the input pin with a pull-high resistor and then measuring the input sink current at the specified supply voltage level. Dividing the voltage by this measured current provides the R<sub>PH</sub> value.

## Memory Characteristics

Ta=-40°C~85°C

| Symbol                                    | Parameter                                      | Test Conditions |                      | Min.               | Typ. | Max.               | Unit |
|---|--|-----------------|----------------------|--------------------|------|--------------------|------|
|   |  | V <sub>DD</sub> | Conditions           |                    |      |                    |      |
| V <sub>RW</sub>                           | V <sub>DD</sub> for Read / Write               | —               | —                    | V <sub>DDmin</sub> | —    | V <sub>DDmax</sub> | V    |
| <b>Program Flash / Data EEPROM Memory</b> |  |                 |                      |                    |      |                    |      |
| t <sub>DEW</sub>                          | Erase / Write cycle time                       | —               | —                    | 2.2                | 2.5  | 2.8                | ms   |
| I <sub>DDPGM</sub>                        | Programming / Erase current on V <sub>DD</sub> | —               | —                    | —                  | —    | 5.0                | mA   |
| E <sub>P</sub>                            | Cell Endurance – Flash Program Memory          | —               | —                    | 10K                | —    | —                  | E/W  |
|   | Cell Endurance – Data EEPROM Memory            | —               | —                    | 100K               | —    | —                  | E/W  |
| t <sub>RETD</sub>                         | ROM Data Retention time                        | —               | Ta=25°C              | —                  | 40   | —                  | Year |
| <b>RAM Data Memory</b>                    |  |                 |                      |                    |      |                    |      |
| V <sub>DR</sub>                           | RAM Data Retention voltage                     | —               | Device in SLEEP Mode | 1.0                | —    | —                  | V    |

## A/D Converter Electrical Characteristics

Ta=25°C

| Symbol             | Parameter   | Test Conditions |  | Min.                  | Typ. | Max.                  | Unit              |
|--------------------|---|-----------------|--|-----------------------|------|-----------------------|-------------------|
|                    |   | V <sub>DD</sub> | Conditions   |                       |      |                       |                   |
| V <sub>DD</sub>    | Operating Voltage                                       | —               | —  | 2.2                   | —    | 5.5                   | V                 |
| V <sub>ADI</sub>   | Input Voltage   | —               | —  | 0                     | —    | V <sub>REF</sub>      | V                 |
| V <sub>REF</sub>   | Reference Voltage                                       | —               | —  | 2                     | —    | V <sub>DD</sub>       | V                 |
| DNL                | Differential Non-linearity                              | —               | V <sub>REF</sub> =V <sub>DD</sub> , t <sub>ADCK</sub> =0.5μs,<br>Ta=-40°C~85°C | -3                    | —    | +3                    | LSB               |
| INL                | Integral Non-linearity                                  | —               | V <sub>REF</sub> =V <sub>DD</sub> , t <sub>ADCK</sub> =0.5μs,<br>Ta=-40°C~85°C | -4                    | —    | +4                    | LSB               |
| I <sub>ADC</sub>   | Additional Current Consumption for A/D Converter Enable | 2.2V            | No load (t <sub>ADCK</sub> =0.5μs)   | —                     | 1.0  | 2.0                   | mA                |
|                    |   | 3V              | No load (t <sub>ADCK</sub> =0.5μs)   | —                     | 1.0  | 2.0                   | mA                |
|                    |   | 5V              | No load (t <sub>ADCK</sub> =0.5μs)   | —                     | 1.5  | 3.0                   | mA                |
| t <sub>ADCK</sub>  | Clock Period  | —               | —  | 0.5                   | —    | 10                    | μs                |
| t <sub>ADS</sub>   | Sampling Time   | —               | —  | —                     | 4    | —                     | t <sub>ADCK</sub> |
| t <sub>ADC</sub>   | Conversion Time (Including A/D Sample and Hold Time)    | —               | —  | —                     | 16   | —                     | t <sub>ADCK</sub> |
| t <sub>ON2ST</sub> | A/D Converter On-to-Start Time                          | —               | —  | 4                     | —    | —                     | μs                |
| t <sub>START</sub> | OPA Turn on Stable Time                                 | —               | No external load   | —                     | —    | 22                    | μs                |
| I <sub>PGA</sub>   | Additional Current Consumption for PGA Enable           | 3V              | No load  | —                     | 300  | 450                   | μA                |
|                    |   | 5V              |  | —                     | 400  | 550                   |                   |
| V <sub>CM</sub>    | PGA Common Mode Voltage Range                           | 3V              | —  | V <sub>SS</sub> - 0.3 | —    | V <sub>DD</sub> - 1.4 | V                 |
|                    |   | 5V              |  |                       |      |                       |                   |
| V <sub>OR</sub>    | PGA Maximum Output Voltage Range                        | 3V              | —  | V <sub>SS</sub> + 0.1 | —    | V <sub>DD</sub> - 0.1 | V                 |
|                    |   | 5V              |  |                       |      |                       |                   |
| V <sub>VR</sub>    | PGA Fix Voltage Output                                  | 5V              | —  | -1%                   | 2    | +1%                   | V                 |
|                    |   | 5V              | —  | -1%                   | 3    | +1%                   | V                 |
|                    |   | 5V              | —  | -1%                   | 4    | +1%                   | V                 |

## Comparator Electrical Characteristics

Ta=25°C

| Symbol           | Parameter  | Test Conditions |   | Min.            | Typ.       | Max.                 | Unit |
|------------------|--|-----------------|---|-----------------|------------|----------------------|------|
|                  |  | V <sub>DD</sub> | Conditions  |                 |            |                      |      |
| V <sub>DD</sub>  | Operating Voltage                                    | —               | —   | 2.7             | —          | 5.5                  | V    |
| I <sub>CMP</sub> | Additional Current Consumption for Comparator Enable | 3V<br>5V        | CNV <sub>Tn</sub> [1:0]=00  | —<br>—          | —<br>1     | 3<br>3               | μA   |
| V <sub>OS</sub>  | Input Offset Voltage <sup>(Note)</sup>               | 3V/5V<br>3V/5V  | Without calibration, CNV <sub>Tn</sub> [1:0]=00B, CnOF[4:0]=10000<br>With calibration, CNV <sub>Tn</sub> [1:0]=00B                                  | -10<br>-4       | —<br>—     | 10<br>4              | mV   |
| V <sub>CM</sub>  | Common Mode Voltage Range                            | —               | CNV <sub>Tn</sub> [1:0]=00  | V <sub>SS</sub> | —          | V <sub>DD</sub> -1.4 | V    |
| A <sub>OL</sub>  | Open Loop Gain                                       | 3V<br>5V        | CNV <sub>Tn</sub> [1:0]=00  | 60<br>60        | —<br>80    | —<br>—               | dB   |
| V <sub>HYS</sub> | Hysteresis   | 3V<br>5V        | CNV <sub>Tn</sub> [1:0]=00  | 10<br>10        | —<br>24    | 30<br>30             | mV   |
| t <sub>RP</sub>  | Response Time  | 3V/5V           | With 10mV overdrive, C <sub>LOAD</sub> =3pF, CNV <sub>Tn</sub> [1:0]=00<br>With 100mV overdrive, C <sub>LOAD</sub> =3pF, CNV <sub>Tn</sub> [1:0]=00 | —<br>—          | 25<br>20   | 40<br>40             | μs   |
|                  |  | 3V/5V           | With 10mV overdrive, C <sub>LOAD</sub> =3pF, CNV <sub>Tn</sub> [1:0]=01<br>With 100mV overdrive, C <sub>LOAD</sub> =3pF, CNV <sub>Tn</sub> [1:0]=01 | —<br>—          | 1.5<br>1.2 | 4<br>3               |      |
|                  |  | 3V/5V           | With 10mV overdrive, C <sub>LOAD</sub> =3pF, CNV <sub>Tn</sub> [1:0]=10<br>With 100mV overdrive, C <sub>LOAD</sub> =3pF, CNV <sub>Tn</sub> [1:0]=10 | —<br>—          | 0.8<br>0.5 | 2<br>1.5             |      |
|                  |  | 3V/5V           | With 10mV overdrive, C <sub>LOAD</sub> =3pF, CNV <sub>Tn</sub> [1:0]=11<br>With 100mV overdrive, C <sub>LOAD</sub> =3pF, CNV <sub>Tn</sub> [1:0]=11 | —<br>—          | 0.7<br>0.3 | 1.5<br>1             |      |

Note: The input offset voltage should first be calibrated when the comparator operates with the compared threshold voltage level lower than 250mV. Otherwise, the input offset voltage will be out of specification.

## Software Controlled LCD Driver Electrical Characteristics

Ta=25°C

| Symbol            | Parameter                                      | Test Conditions |              | Min.                 | Typ.               | Max.                 | Unit |
|-------------------|--|-----------------|--------------|----------------------|--------------------|----------------------|------|
|                   |  | V <sub>DD</sub> | Conditions   |                      |                    |                      |      |
| I <sub>BIAS</sub> | V <sub>DD</sub> /2 Bias current                | 3V              | ISEL[1:0]=00 | 8                    | —                  | 16                   | μA   |
|                   |  | 5V              |              | 17.5                 | 25                 | 32.5                 |      |
|                   |  | 3V              | ISEL[1:0]=01 | 18                   | —                  | 32                   |      |
|                   |  | 5V              |              | 35                   | 50                 | 65                   |      |
|                   |  | 3V              | ISEL[1:0]=10 | 35                   | —                  | 65                   |      |
|                   |  | 5V              |              | 70                   | 100                | 130                  |      |
|                   |  | 3V              | ISEL[1:0]=11 | 70                   | —                  | 130                  |      |
|                   |  | 5V              |              | 140                  | 200                | 260                  |      |
| V <sub>SCOM</sub> | V <sub>DD</sub> /2 Voltage for LCD SCOM Output | 2.2V~5.5V       | No load      | 0.475V <sub>DD</sub> | 0.5V <sub>DD</sub> | 0.525V <sub>DD</sub> | V    |

## I<sup>2</sup>C Characteristics

Ta=25°C

| Symbol           | Parameter  | Test Condition  |                          | Min. | Typ. | Max. | Unit |
|------------------|--|-----------------|--------------------------|------|------|------|------|
|                  |  | V <sub>DD</sub> | Condition                |      |      |      |      |
| f <sub>I2C</sub> | System Frequency for I <sup>2</sup> C Standard Mode (100kHz) | —               | No clock debounce        | 2    | —    | —    | MHz  |
|                  |  | —               | 2 system clocks debounce | 4    | —    | —    |      |
|                  |  | —               | 4 system clocks debounce | 8    | —    | —    |      |
|                  | System Frequency for I <sup>2</sup> C Fast Mode (400kHz)     | —               | No clock debounce        | 5    | —    | —    | MHz  |
|                  |  | —               | 2 system clocks debounce | 10   | —    | —    |      |
|                  |  | —               | 4 system clocks debounce | 20   | —    | —    |      |

## LVD/LVR Electrical Characteristics

Ta=25°C

| Symbol                           | Parameter                                     | Test Conditions |  | Min. | Typ. | Max. | Unit |
|----------------------------------|---|-----------------|--|------|------|------|------|
|                                  |   | V <sub>DD</sub> | Conditions                             |      |      |      |      |
| V <sub>LVR</sub>                 | Low Voltage Reset Voltage                     | —               | LVR enabled, voltage select 2.1V       | - 5% | 2.1  | + 5% | V    |
|                                  |   |                 | LVR enabled, voltage select 2.55V      |      | 2.55 |      |      |
|                                  |   |                 | LVR enabled, voltage select 3.15V      |      | 3.15 |      |      |
|                                  |   |                 | LVR enabled, voltage select 3.8V       |      | 3.8  |      |      |
| V <sub>LVD</sub>                 | Low Voltage Detect Voltage                    | —               | LVD enabled, voltage select 2.0V       | - 5% | 2.0  | + 5% | V    |
|                                  |   |                 | LVD enabled, voltage select 2.2V       |      | 2.2  |      |      |
|                                  |   |                 | LVD enabled, voltage select 2.4V       |      | 2.4  |      |      |
|                                  |   |                 | LVD enabled, voltage select 2.7V       |      | 2.7  |      |      |
|                                  |   |                 | LVD enabled, voltage select 3.0V       |      | 3.0  |      |      |
|                                  |   |                 | LVD enabled, voltage select 3.3V       |      | 3.3  |      |      |
|                                  |   |                 | LVD enabled, voltage select 3.6V       |      | 3.6  |      |      |
| LVD enabled, voltage select 4.0V | 4.0   |                 |  |      |      |      |      |
| I <sub>LVR</sub>                 | Additional Current Consumption for LVR Enable | —               | LVD disabled, VBGEN=0                  | —    | —    | 25   | μA   |
| I <sub>LVD</sub>                 | Additional Current Consumption for LVD Enable | —               | LVR disabled, VBGEN=0                  | —    | —    | 25   | μA   |
| t <sub>LVDs</sub>                | LVDO Stable Time                              | —               | For LVR enable, VBGEN=0, LVD off → on  | —    | —    | 15   | μs   |
|                                  |   | —               | For LVR disable, VBGEN=0, LVD off → on | —    | —    | 150  | μs   |
| t <sub>LVR</sub>                 | Minimum Low Voltage Width to Reset            | —               | —                                      | 120  | 240  | 480  | μs   |
| t <sub>BGS</sub>                 | V <sub>BG</sub> Turn on Stable Time           | —               | No load                                | —    | —    | 200  | μs   |
| t <sub>LVD</sub>                 | Minimum Low Voltage Width to Interrupt        | —               | —                                      | 60   | 120  | 240  | μs   |

## Power-on Reset Characteristics

Ta=25°C

| Symbol            | Parameter   | Test Conditions |            | Min.  | Typ. | Max. | Unit |
|-------------------|---|-----------------|------------|-------|------|------|------|
|                   |   | V <sub>DD</sub> | Conditions |       |      |      |      |
| V <sub>POR</sub>  | V <sub>DD</sub> Start Voltage to Ensure Power-on Reset                              | —               | —          | —     | —    | 100  | mV   |
| RR <sub>POR</sub> | V <sub>DD</sub> Rising Rate to Ensure Power-on Reset                                | —               | —          | 0.035 | —    | —    | V/ms |
| t <sub>POR</sub>  | Minimum Time for V <sub>DD</sub> Stays at V <sub>POR</sub> to Ensure Power-on Reset | —               | —          | 1     | —    | —    | ms   |

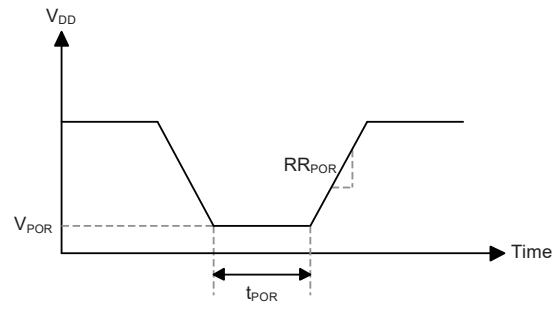

## System Architecture

A key factor in the high-performance features of the Holtek range of microcontrollers is attributed to their internal system architecture. The range of devices take advantage of the usual features found within RISC microcontrollers providing increased speed of operation and enhanced performance. The pipelining scheme is implemented in such a way that instruction fetching and instruction execution are overlapped, hence instructions are effectively executed in one cycle, with the exception of branch or call instructions. An 8-bit wide ALU is used in practically all instruction set operations, which carries out arithmetic operations, logic operations, rotation, increment, decrement, branch decisions, etc. The internal data path is simplified by moving data through the Accumulator and the ALU. Certain internal registers are implemented in the Data Memory and can be directly or indirectly addressed. The simple addressing methods of these registers along with additional architectural features ensure that a minimum of external components is required to provide a functional I/O and A/D control system with maximum reliability and flexibility. This makes these devices suitable for low-cost, high-volume production for controller applications.

### Clocking and Pipelining

The main system clock, derived from either a HXT, LXT, HIRC or LIRC oscillator is subdivided into four internally generated non-overlapping clocks, T1~T4. The Program Counter is incremented at the beginning of the T1 clock during which time a new instruction is fetched. The remaining T2~T4 clocks carry out the decoding and execution functions. In this way, one T1~T4 clock cycle forms one instruction cycle. Although the fetching and execution of instructions takes place in consecutive instruction cycles, the pipelining structure of the microcontroller ensures that instructions are effectively executed in one instruction cycle. The exception to this are instructions where the contents of the Program Counter are changed, such as subroutine calls or jumps, in which case the instruction will take one more instruction cycle to execute.

For instructions involving branches, such as jump or call instructions, two machine cycles are required to complete instruction execution. An extra cycle is required as the program takes one cycle to first obtain the actual jump or call address and then another cycle to actually execute the branch. The requirement for this extra cycle should be taken into account by programmers in timing sensitive applications.

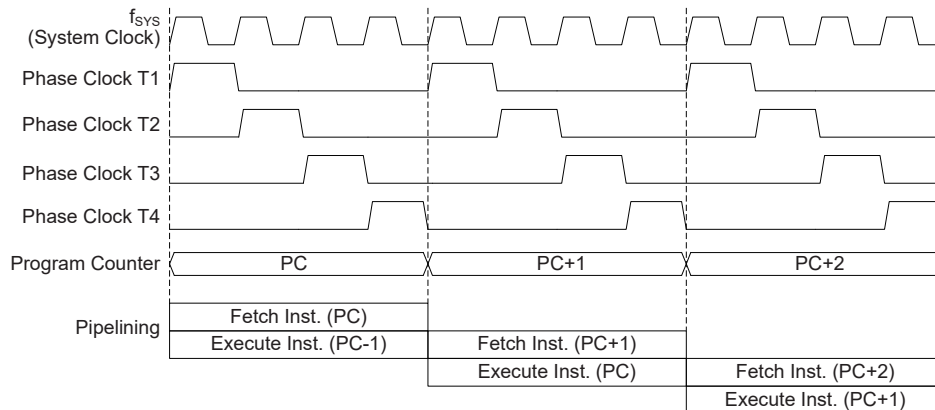

**System Clocking and Pipelining**

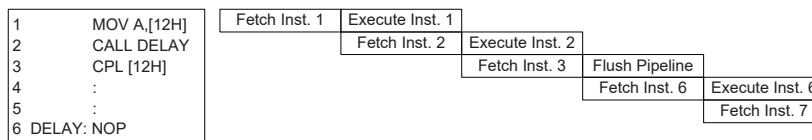

**Instruction Fetching**

### Program Counter

During program execution, the Program Counter is used to keep track of the address of the next instruction to be executed. It is automatically incremented by one each time an instruction is executed except for instructions, such as "JMP" or "CALL" that demand a jump to a non-consecutive Program Memory address. For the device whose memory capacity is greater than 8K words the Program Memory address may be located in a certain program memory bank which is selected by the program memory bank pointer bits, PBPn. Only the lower 8 bits, known as the Program Counter Low Register, are directly addressable by the application program.

When executing instructions requiring jumps to non-consecutive addresses such as a jump instruction, a subroutine call, interrupt or reset, etc., the microcontroller manages program control by loading the required address into the Program Counter. For conditional skip instructions, once the condition has been met, the next instruction, which has already been fetched during the present instruction execution, is discarded and a dummy cycle takes its place while the correct instruction is obtained.

| Device    | Program Counter     |                |
|-----------|---------------------|----------------|
|           | High Byte           | Low Byte (PCL) |
| HT66F2350 | PC12~PC8            | PC7~PC0        |
| HT66F2360 | PBP0, PC12~PC8      | PC7~PC0        |
| HT66F2370 | PBP1~PBP0, PC12~PC8 | PC7~PC0        |
| HT66F2390 | PBP2~PBP0, PC12~PC8 | PC7~PC0        |

**Program Counter**

The lower byte of the Program Counter, known as the Program Counter Low register or PCL, is available for program control and is a readable and writeable register. By transferring data directly into this register, a short program jump can be executed directly; however, as only this low byte is available for manipulation, the jumps are limited to the present page of memory that is 256 locations. When such program jumps are executed it should also be noted that a dummy cycle will be inserted. Manipulating the PCL register may cause program branching, so an extra cycle is needed to pre-fetch.

## Stack

This is a special part of the memory which is used to save the contents of the Program Counter only. The stack has multiple levels and is neither part of the data nor part of the program space, and is neither readable nor writeable. The activated level is indexed by the Stack Pointer, and is neither readable nor writeable. At a subroutine call or interrupt acknowledge signal, the contents of the Program Counter are pushed onto the stack. At the end of a subroutine or an interrupt routine, signaled by a return instruction, RET or RETI, the Program Counter is restored to its previous value from the stack. After a device reset, the Stack Pointer will point to the top of the stack.

If the stack is full and an enabled interrupt takes place, the interrupt request flag will be recorded but the acknowledge signal will be inhibited. When the Stack Pointer is decremented, by RET or RETI, the interrupt will be serviced. This feature prevents stack overflow allowing the programmer to use the structure more easily. However, when the stack is full, a CALL subroutine instruction can still be executed which will result in a stack overflow. Precautions should be taken to avoid such cases which might cause unpredictable program branching.

If the stack is overflow, the first Program Counter save in the stack will be lost.

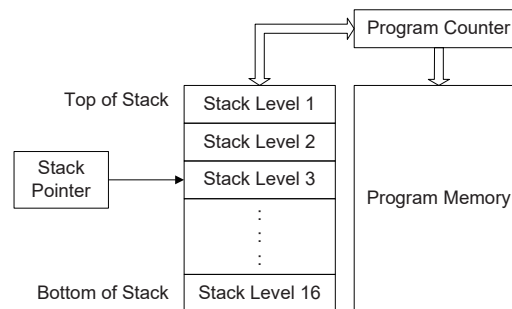

## Arithmetic and Logic Unit – ALU

The arithmetic-logic unit or ALU is a critical area of the microcontroller that carries out arithmetic and logic operations of the instruction set. Connected to the main microcontroller data bus, the ALU receives related instruction codes and performs the required arithmetic or logical operations after which the result will be placed in the specified register. As these ALU calculation or operations may result in carry, borrow or other status changes, the status register will be correspondingly updated to reflect these changes. The ALU supports the following functions:

- Arithmetic operations:  
 ADD, ADDM, ADC, ADCM, SUB, SUBM, SBC, SBCM, DAA  
 LADD, LADDM, LADC, LADCM, LSUB, LSUBM, LSBC, LSBCM, LDAA
- Logic operations:  
 AND, OR, XOR, ANDM, ORM, XORM, CPL, CPLA  
 LAND, LOR, LXOR, LANDM, LORM, LXORM, LCPL, LCPLA
- Rotation:  
 RRA, RR, RRCA, RRC, RLA, RL, RLCA, RLC  
 LRRR, LRR, LRRCA, LRRR, LRLA, LRL, LRLCA, LRLC
- Increment and Decrement:  
 INCA, INC, DECA, DEC  
 LINCA, LINC, LDECA, LDEC
- Branch decision:  
 JMP, SZ, SZA, SNZ, SIZ, SDZ, SIZA, SDZA, CALL, RET, RETI  
 LSZ, LSZA, LSNZ, LSIZ, LSDZ, LSIZA, LSDZA

## Flash Program Memory

The Program Memory is the location where the user code or program is stored. For these devices series the Program Memory are Flash type, which means it can be programmed and re-programmed a large number of times, allowing the user the convenience of code modification on the same device. By using the appropriate programming tools, these Flash devices offer users the flexibility to conveniently debug and develop their applications while also offering a means of field programming and updating.

| Device    | Capacity | Banks |
|-----------|----------|-------|
| HT66F2350 | 8K×16    | —     |
| HT66F2360 | 16K×16   | 0~1   |
| HT66F2370 | 32K×16   | 0~3   |
| HT66F2390 | 64K×16   | 0~7   |

### Structure

The Program Memory has a capacity of 8K×16 to 64K×16 bits. The Program Memory is addressed by the Program Counter and also contains data, table information and interrupt entries. Table data, which can be setup in any location within the Program Memory, is addressed by a separate table pointer registers.

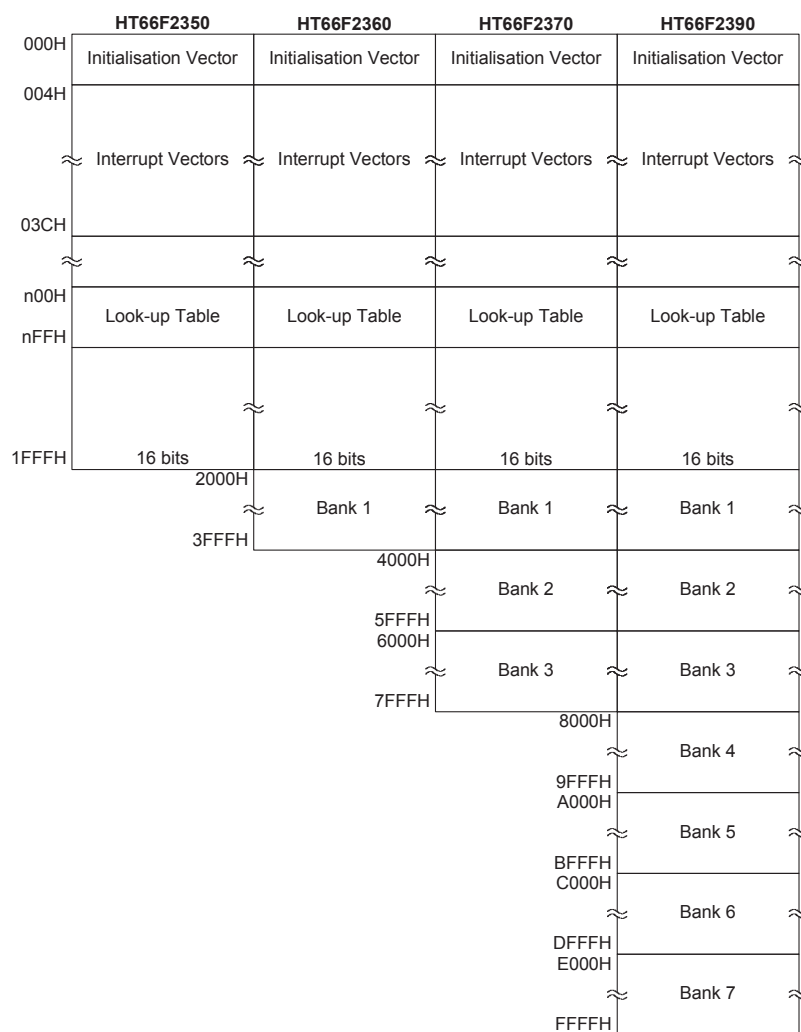

**Program Memory Structure**

## Special Vectors

Within the Program Memory, certain locations are reserved for the reset and interrupts. The location 000H is reserved for use by these devices reset for program initialisation. After a device reset is initiated, the program will jump to this location and begin execution.

## Look-up Table

Any location within the Program Memory can be defined as a look-up table where programmers can store fixed data. To use the look-up table, the table pointer must first be setup by placing the address of the look up data to be retrieved in the table pointer register, TBLP and TBHP. These registers define the total address of the look-up table.

After setting up the table pointer, the table data can be retrieved from the Program Memory using the "TABRD [m]" or "TABRDL [m]" instructions respectively when the memory [m] is located in sector 0. If the memory [m] is located in other sectors except sector 0, the data can be retrieved from the program memory using the corresponding extended table read instruction such as "LTABRD [m]" or "LTABRDL [m]" respectively. When the instruction is executed, the lower order table byte from the Program Memory will be transferred to the user defined Data Memory register [m] as specified in the instruction. The higher order table data byte from the Program Memory will be transferred to the TBLH special register. Any unused bits in this transferred higher order byte will be read as "0".

The accompanying diagram illustrates the addressing data flow of the look-up table.

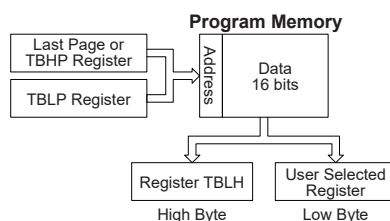

## Table Program Example

The accompanying example shows how the table pointer and table data is defined and retrieved from the device. This example uses raw table data located in the last page which is stored there using the ORG statement. The value at this ORG statement is "1F00H" which refers to the start address of the last page within the 8K Program Memory of the device. The table pointer low byte register is setup here to have an initial value of "06H". This will ensure that the first data read from the data table will be at the Program Memory address "1F06H" or 6 locations after the start of the last page. Note that the value for the table pointer is referenced to the first address of the present page pointed by the TBHP register if the "TABRD [m]" instruction is being used. The high byte of the table data which in this case is equal to zero will be transferred to the TBLH register automatically when the "TABRD [m]" instruction is executed.

Because the TBLH register is a read/write register and can be restored, care should be taken to ensure its protection if both the main routine and Interrupt Service Routine use table read instructions. If using the table read instructions, the Interrupt Service Routines may change the value of the TBLH and subsequently cause errors if used again by the main routine. As a rule it is recommended that simultaneous use of the table read instructions should be avoided. However, in situations where simultaneous use cannot be avoided, the interrupts should be disabled prior to the execution of any main routine table-read instructions. Note that all table related instructions require two instruction cycles to complete their operation.

### Table Read Program Example

```

tempreg1 db ?      ; temporary register #1
tempreg2 db ?      ; temporary register #2
:
mov a,06h          ; initialise low table pointer - note that this address is referenced
mov tblp,a         ; to the last page or the page that tbhp pointed
mov a,1fh          ; initialise high table pointer
mov tbhp,a
:
tabrd tempreg1     ; transfers value in table referenced by table pointer data at program
                  ; memory address "1F06H" transferred to tempreg1 and TBLH
dec tblp           ; reduce value of table pointer by one
tabrd tempreg2     ; transfers value in table referenced by table pointer data at program
                  ; memory address "1F05H" transferred to tempreg2 and TBLH in this
                  ; example the data "1AH" is transferred to tempreg1 and data "0FH" to
                  ; register tempreg2
:
org 1F00h          ; sets initial address of program memory
dc 00Ah, 00Bh, 00Ch, 00Dh, 00Eh, 00Fh, 01Ah, 01Bh
:

```

### In Circuit Programming – ICP

The provision of Flash type Program Memory provides the user with a means of convenient and easy upgrades and modifications to their programs on the same device.

As an additional convenience, Holtek has provided a means of programming the microcontroller in-circuit using a 4-pin interface. This provides manufacturers with the possibility of manufacturing their circuit boards complete with a programmed or un-programmed microcontroller, and then programming or upgrading the program at a later stage. This enables product manufacturers to easily keep their manufactured products supplied with the latest program releases without removal and re-insertion of the device.

| Holtek Writer Pins | MCU Programming Pins | Pin Description                 |
|--------------------|----------------------|---------------------------------|
| ICPDA              | PA0                  | Programming Serial Data/Address |
| ICPCK              | PA2                  | Programming Clock               |
| VDD                | VDD                  | Power Supply                    |
| VSS                | VSS                  | Ground                          |

The Program Memory can be programmed serially in-circuit using this 4-wire interface. Data is downloaded and uploaded serially on a single pin with an additional line for the clock. Two additional lines are required for the power supply. The technical details regarding the in-circuit programming of the device are beyond the scope of this document and will be supplied in supplementary literature.

During the programming process, the user must take care of the ICPDA and ICPCK pins for data and clock programming purposes to ensure that no other outputs are connected to these two pins.

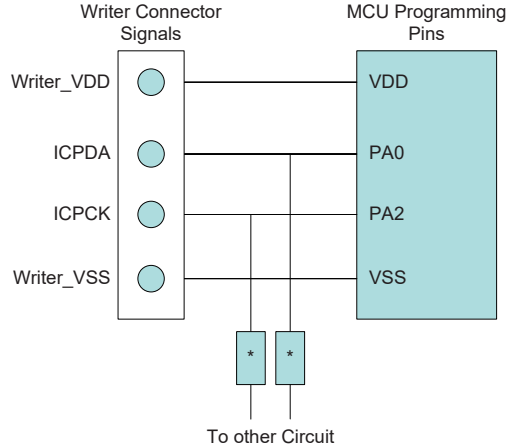

Note: \* may be resistor or capacitor. The resistance of \* must be greater than 1k or the capacitance of \* must be less than 1nF.

### On-Chip Debug Support – OCDS

There is an EV chip named HT66V23x0 which is used to emulate the real MCU device named HT66F23x0. The EV chip device also provides the "On-Chip Debug" function to debug the real MCU device during development process. The EV chip and real MCU devices, HT66V23x0 and HT66F23x0, are almost functional compatible except the "On-Chip Debug" function. Users can use the EV chip device to emulate the real MCU device behaviors by connecting the OCSDSA and OCDSCK pins to the Holtek HT-IDE development tools. The OCSDSA pin is the OCDS Data/Address input/output pin while the OCDSCK pin is the OCDS clock input pin. When users use the EV chip device for debugging, the corresponding pin functions shared with the OCSDSA and OCDSCK pins in the real MCU device will have no effect in the EV chip. However, the two OCDS pins which are pin-shared with the ICP programming pins are still used as the Flash Memory programming pins for ICP. For more detailed OCDS information, refer to the corresponding document named "Holtek e-Link for 8-bit MCU OCDS User's Guide".

| Holtek e-Link Pins | EV Chip OCDS Pins | Pin Description                                 |
|--------------------|-------------------|---|
| OCSDSA             | OCSDSA            | On-Chip Debug Support Data/Address input/output |
| OCDSCK             | OCDSCK            | On-Chip Debug Support Clock input               |
| VDD                | VDD, AVDD         | Power Supply                                    |
| VSS                | VSS, AVSS         | Ground  |

## In Application Programming – IAP

These devices offer IAP function to update data or application program to flash ROM. Users can define any ROM location for IAP, but there are some features which user must notice in using IAP function.

| HT66F2350 Configurations |                 | HT66F2360/HT66F2370 Configurations |                 | HT66F2390 Configurations |                  |
|--------------------------|-----------------|------------------------------------|-----------------|--------------------------|------------------|
| Erase Page               | 32 words / page | Erase Page                         | 64 words / page | Erase Page               | 128 words / page |
| Writing Word             | 32 words / time | Writing Word                       | 64 words / time | Writing Word             | 128 words / time |
| Reading Word             | 1 word / time   | Reading Word                       | 1 word / time   | Reading Word             | 1 word / time    |

## In Application Programming Control Registers

The Address register, FARL and FARH, the Data registers, FD0L/FD0H, FD1L/FD1H, FD2L/FD2H and FD3L/FD3H, and the Control registers, FC0, FC1 and FC2, are the corresponding Flash access registers located in Data Memory sector 0 and sector 1 respectively for IAP. If using the indirect addressing method to access the FC0, FC1 and FC2 registers, all read and write operations to the registers must be performed using the Indirect Addressing Register, IAR1 or IAR2, and the Memory Pointer pair, MP1L/MP1H or MP2L/MP2H. Because the FC0, FC1 and FC2 control registers are located at the address of 43H~45H in Data Memory sector 1, the desired value ranged from 43H to 45H must first be written into the MP1L or MP2L Memory Pointer low byte and the value "01H" must also be written into the MP1H or MP2H Memory Pointer high byte.

| Register Name    | Bit   |       |       |       |       |     |       |      |
|------------------|-------|-------|-------|-------|-------|-----|-------|------|
|                  | 7     | 6     | 5     | 4     | 3     | 2   | 1     | 0    |
| FC0              | CFWEN | FMOD2 | FMOD1 | FMOD0 | FWPEN | FWT | FRDEN | FRD  |
| FC1              | D7    | D6    | D5    | D4    | D3    | D2  | D1    | D0   |
| FC2              | —     | —     | —     | —     | —     | —   | —     | CLWB |
| FARL             | A7    | A6    | A5    | A4    | A3    | A2  | A1    | A0   |
| FARH (HT66F2350) | —     | —     | —     | A12   | A11   | A10 | A9    | A8   |
| FARH (HT66F2360) | —     | —     | A13   | A12   | A11   | A10 | A9    | A8   |
| FARH (HT66F2370) | —     | A14   | A13   | A12   | A11   | A10 | A9    | A8   |
| FARH (HT66F2390) | A15   | A14   | A13   | A12   | A11   | A10 | A9    | A8   |
| FD0L             | D7    | D6    | D5    | D4    | D3    | D2  | D1    | D0   |
| FD0H             | D15   | D14   | D13   | D12   | D11   | D10 | D9    | D8   |
| FD1L             | D7    | D6    | D5    | D4    | D3    | D2  | D1    | D0   |
| FD1H             | D15   | D14   | D13   | D12   | D11   | D10 | D9    | D8   |
| FD2L             | D7    | D6    | D5    | D4    | D3    | D2  | D1    | D0   |
| FD2H             | D15   | D14   | D13   | D12   | D11   | D10 | D9    | D8   |
| FD3L             | D7    | D6    | D5    | D4    | D3    | D2  | D1    | D0   |
| FD3H             | D15   | D14   | D13   | D12   | D11   | D10 | D9    | D8   |

IAP Registers List

• **FC0 Register**

| Bit  | 7     | 6     | 5     | 4     | 3     | 2   | 1     | 0   |
|------|-------|-------|-------|-------|-------|-----|-------|-----|
| Name | CFWEN | FMOD2 | FMOD1 | FMOD0 | FWPEN | FWT | FRDEN | FRD |
| R/W  | R/W   | R/W   | R/W   | R/W   | R/W   | R/W | R/W   | R/W |
| POR  | 0     | 0     | 0     | 0     | 0     | 0   | 0     | 0   |

- Bit 7**      **CFWEN:** Flash Memory Write enable control  
0: Flash memory write function is disabled  
1: Flash memory write function has been successfully enabled  
When this bit is cleared to 0 by application program, the Flash memory write function is disabled. Note that writing a "1" into this bit results in no action. This bit is used to indicate that the Flash memory write function status. When this bit is set to 1 by hardware, it means that the Flash memory write function is enabled successfully. Otherwise, the Flash memory write function is disabled as the bit content is zero.
- Bit 6~4**    **FMOD2~FMOD0:** Mode selection  
000: Write program memory  
001: Page erase program memory  
010: Reserved  
011: Read program memory  
10x: Reserved  
110: FWEN mode – Flash memory Write function Enabled mode  
111: Reserved
- Bit 3**      **FWPEN:** Flash memory Write Procedure Enable control  
0: Disable  
1: Enable  
When this bit is set to 1 and the FMOD field is set to "110", the IAP controller will execute the "Flash memory write function enable" procedure. Once the Flash memory write function is successfully enabled, it is not necessary to set the FWPEN bit any more.
- Bit 2**      **FWT:** Flash memory Write Initiate control  
0: Do not initiate Flash memory write or Flash memory write process is completed  
1: Initiate Flash memory write process  
This bit is set by software and cleared by hardware when the Flash memory write process is completed.
- Bit 1**      **FRDEN:** Flash memory Read Enable control  
0: Flash memory read disable  
1: Flash memory read enable
- Bit 0**      **FRD:** Flash memory Read Initiate control  
0: Do not initiate Flash memory read or Flash memory read process is completed  
1: Initiate Flash memory read process  
This bit is set by software and cleared by hardware when the Flash memory read process is completed.

• **FC1 Register**

| Bit  | 7   | 6   | 5   | 4   | 3   | 2   | 1   | 0   |
|------|-----|-----|-----|-----|-----|-----|-----|-----|
| Name | D7  | D6  | D5  | D4  | D3  | D2  | D1  | D0  |
| R/W  | R/W | R/W | R/W | R/W | R/W | R/W | R/W | R/W |
| POR  | 0   | 0   | 0   | 0   | 0   | 0   | 0   | 0   |

- Bit 7~0**    **D7~D0:** Whole chip reset pattern  
When user writes a specific value of "55H" to this register, it will generate a reset signal to reset whole chip.

• **FC2 Register**

| Bit  | 7 | 6 | 5 | 4 | 3 | 2 | 1 | 0    |
|------|---|---|---|---|---|---|---|------|
| Name | — | — | — | — | — | — | — | CLWB |
| R/W  | — | — | — | — | — | — | — | R/W  |
| POR  | — | — | — | — | — | — | — | 0    |

Bit 7~1 Unimplemented, read as "0"

Bit 0 **CLWB**: Flash memory Write Buffer Clear control

0: Do not initiate Write Buffer Clear process or Write Buffer Clear process is completed

1: Initiate Write Buffer Clear process

This bit is set by software and cleared by hardware when the Write Buffer Clear process is completed.

• **FARL Register**

| Bit  | 7   | 6   | 5   | 4   | 3   | 2   | 1   | 0   |
|------|-----|-----|-----|-----|-----|-----|-----|-----|
| Name | A7  | A6  | A5  | A4  | A3  | A2  | A1  | A0  |
| R/W  | R/W | R/W | R/W | R/W | R/W | R/W | R/W | R/W |
| POR  | 0   | 0   | 0   | 0   | 0   | 0   | 0   | 0   |

Bit 7~0 Flash Memory Address bit 7 ~ bit 0

• **FARH Register – HT66F2350**

| Bit  | 7 | 6 | 5 | 4   | 3   | 2   | 1   | 0   |
|------|---|---|---|-----|-----|-----|-----|-----|
| Name | — | — | — | A12 | A11 | A10 | A9  | A8  |
| R/W  | — | — | — | R/W | R/W | R/W | R/W | R/W |
| POR  | — | — | — | 0   | 0   | 0   | 0   | 0   |

Bit 7~5 Unimplemented, read as "0"

Bit 4~0 Flash Memory Address bit 12 ~ bit 8

• **FARH Register – HT66F2360**

| Bit  | 7 | 6 | 5   | 4   | 3   | 2   | 1   | 0   |
|------|---|---|-----|-----|-----|-----|-----|-----|
| Name | — | — | A13 | A12 | A11 | A10 | A9  | A8  |
| R/W  | — | — | R/W | R/W | R/W | R/W | R/W | R/W |
| POR  | — | — | 0   | 0   | 0   | 0   | 0   | 0   |

Bit 7~6 Unimplemented, read as "0"

Bit 5~0 Flash Memory Address bit 13 ~ bit 8

• **FARH Register – HT66F2370**

| Bit  | 7 | 6   | 5   | 4   | 3   | 2   | 1   | 0   |
|------|---|-----|-----|-----|-----|-----|-----|-----|
| Name | — | A14 | A13 | A12 | A11 | A10 | A9  | A8  |
| R/W  | — | R/W | R/W | R/W | R/W | R/W | R/W | R/W |
| POR  | — | 0   | 0   | 0   | 0   | 0   | 0   | 0   |

Bit 7 Unimplemented, read as "0"

Bit 6~0 Flash Memory Address bit 14 ~ bit 8

• **FARH Register – HT66F2390**

| Bit  | 7   | 6   | 5   | 4   | 3   | 2   | 1   | 0   |
|------|-----|-----|-----|-----|-----|-----|-----|-----|
| Name | A15 | A14 | A13 | A12 | A11 | A10 | A9  | A8  |
| R/W  | R/W | R/W | R/W | R/W | R/W | R/W | R/W | R/W |
| POR  | 0   | 0   | 0   | 0   | 0   | 0   | 0   | 0   |

Bit 7~0 Flash Memory Address bit 15 ~ bit 8

• **FD0L Register**

| Bit  | 7   | 6   | 5   | 4   | 3   | 2   | 1   | 0   |
|------|-----|-----|-----|-----|-----|-----|-----|-----|
| Name | D7  | D6  | D5  | D4  | D3  | D2  | D1  | D0  |
| R/W  | R/W | R/W | R/W | R/W | R/W | R/W | R/W | R/W |
| POR  | 0   | 0   | 0   | 0   | 0   | 0   | 0   | 0   |

Bit 7~0 The first Flash Memory data bit 7 ~ bit 0

Note that the data written into the low byte data register FD0L will only be stored in the FD0L register and not be loaded into the lower 8-bit write buffer.

• **FD0H Register**

| Bit  | 7   | 6   | 5   | 4   | 3   | 2   | 1   | 0   |
|------|-----|-----|-----|-----|-----|-----|-----|-----|
| Name | D15 | D14 | D13 | D12 | D11 | D10 | D9  | D8  |
| R/W  | R/W | R/W | R/W | R/W | R/W | R/W | R/W | R/W |
| POR  | 0   | 0   | 0   | 0   | 0   | 0   | 0   | 0   |

Bit 7~0 The first Flash Memory data bit 15 ~ bit 8

Note that when the 8-bit data is written into the high byte data register FD0H, the whole 16-bit data stored in the FD0H and FD0L registers will simultaneously be loaded into the 16-bit write buffer and then the content of the Flash Memory address register pair, FARH and FARL, will be incremented by one.

• **FD1L Register**

| Bit  | 7   | 6   | 5   | 4   | 3   | 2   | 1   | 0   |
|------|-----|-----|-----|-----|-----|-----|-----|-----|
| Name | D7  | D6  | D5  | D4  | D3  | D2  | D1  | D0  |
| R/W  | R/W | R/W | R/W | R/W | R/W | R/W | R/W | R/W |
| POR  | 0   | 0   | 0   | 0   | 0   | 0   | 0   | 0   |

Bit 7~0 The second Flash Memory data bit 7 ~ bit 0

• **FD1H Register**

| Bit  | 7   | 6   | 5   | 4   | 3   | 2   | 1   | 0   |
|------|-----|-----|-----|-----|-----|-----|-----|-----|
| Name | D15 | D14 | D13 | D12 | D11 | D10 | D9  | D8  |
| R/W  | R/W | R/W | R/W | R/W | R/W | R/W | R/W | R/W |
| POR  | 0   | 0   | 0   | 0   | 0   | 0   | 0   | 0   |

Bit 7~0 The second Flash Memory data bit 15 ~ bit 8

• **FD2L Register**

| Bit  | 7   | 6   | 5   | 4   | 3   | 2   | 1   | 0   |
|------|-----|-----|-----|-----|-----|-----|-----|-----|
| Name | D7  | D6  | D5  | D4  | D3  | D2  | D1  | D0  |
| R/W  | R/W | R/W | R/W | R/W | R/W | R/W | R/W | R/W |
| POR  | 0   | 0   | 0   | 0   | 0   | 0   | 0   | 0   |

Bit 7~0 The third Flash Memory data bit 7 ~ bit 0

• **FD2H Register**

| Bit  | 7   | 6   | 5   | 4   | 3   | 2   | 1   | 0   |
|------|-----|-----|-----|-----|-----|-----|-----|-----|
| Name | D15 | D14 | D13 | D12 | D11 | D10 | D9  | D8  |
| R/W  | R/W | R/W | R/W | R/W | R/W | R/W | R/W | R/W |
| POR  | 0   | 0   | 0   | 0   | 0   | 0   | 0   | 0   |

Bit 7~0 The third Flash Memory data bit 15 ~ bit 8

• **FD3L Register**

| Bit  | 7   | 6   | 5   | 4   | 3   | 2   | 1   | 0   |
|------|-----|-----|-----|-----|-----|-----|-----|-----|
| Name | D7  | D6  | D5  | D4  | D3  | D2  | D1  | D0  |
| R/W  | R/W | R/W | R/W | R/W | R/W | R/W | R/W | R/W |
| POR  | 0   | 0   | 0   | 0   | 0   | 0   | 0   | 0   |

Bit 7~0 The fourth Flash Memory data bit 7 ~ bit 0

• **FD3H Register**

| Bit  | 7   | 6   | 5   | 4   | 3   | 2   | 1   | 0   |
|------|-----|-----|-----|-----|-----|-----|-----|-----|
| Name | D15 | D14 | D13 | D12 | D11 | D10 | D9  | D8  |
| R/W  | R/W | R/W | R/W | R/W | R/W | R/W | R/W | R/W |
| POR  | 0   | 0   | 0   | 0   | 0   | 0   | 0   | 0   |

Bit 7~0 The fourth Flash Memory data bit 15 ~ bit 8

**Flash Memory Write Function Enable Procedure**

In order to allow users to change the Flash memory data through the IAP control registers, users must first enable the Flash memory write operation by the following procedure:

- Step 1. Write "110" into the FMOD2~FMOD0 bits to select the FWEN mode.
- Step 2. Set the FWPEN bit to "1". The step 1 and step 2 can be executed simultaneously.
- Step 3. The pattern data with a sequence of 00H, 04H, 0DH, 09H, C3H and 40H must be written into the FD1L, FD1H, FD2L, FD2H, FD3L and FD3H registers respectively.
- Step 4. A counter with a time-out period of 300 $\mu$ s will be activated to allow users writing the correct pattern data into the FD1L/FD1H ~ FD3L/FD3H register pairs. The counter clock is derived from the LIRC oscillator.
- Step 5. If the counter overflows or the pattern data is incorrect, the Flash memory write operation will not be enabled and users must again repeat the above procedure. Then the FWPEN bit will automatically be cleared to 0 by hardware.
- Step 6. If the pattern data is correct before the counter overflows, the Flash memory write operation will be enabled and the FWPEN bit will automatically be cleared to 0 by hardware. The CFWEN bit will also be set to 1 by hardware to indicate that the Flash memory write operation is successfully enabled.
- Step 7. Once the Flash memory write operation is enabled, the user can change the Flash ROM data through the Flash control register.
- Step 8. To disable the Flash memory write operation, the user can clear the CFWEN bit to 0.

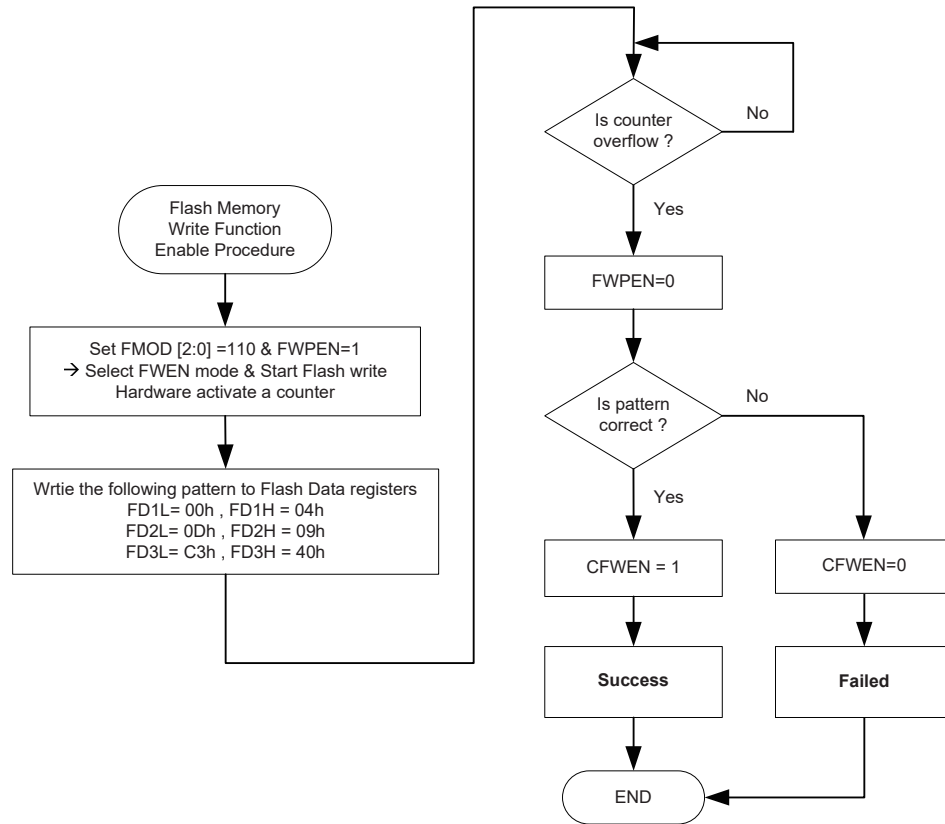

**Flash Memory Write Function Enable Procedure**

**Flash Memory Read/Write Procedure**

After the Flash memory write function is successfully enabled through the preceding IAP procedure, users must first erase the corresponding Flash memory block or page and then initiate the Flash memory write operation. For these devices the number of the page erase operation is 32, 64 and 128 words per page respectively, the available page erase address is specified by FARH register and the content of FARL [7:5], FARL [7:6] and FARL [7] bit field respectively.

| Erase Page | FARH      | FARL [7:5] | FARL [4:0] |
|------------|-----------|------------|------------|
| 0          | 0000 0000 | 000        | x xxxx     |
| 1          | 0000 0000 | 001        | x xxxx     |
| 2          | 0000 0000 | 010        | x xxxx     |
| 3          | 0000 0000 | 011        | x xxxx     |
| 4          | 0000 0000 | 100        | x xxxx     |
| :          | :         | :          | :          |
| 254        | 0001 1111 | 110        | x xxxx     |
| 255        | 0001 1111 | 111        | x xxxx     |

"x": don't care

**HT66F2350 Erase Page Number and Selection**

| Erase Page | FARH      | FARL [7:6] | FARL [5:0] |
|------------|-----------|------------|------------|
| 0          | 0000 0000 | 00         | xx xxxx    |
| 1          | 0000 0000 | 01         | xx xxxx    |
| 2          | 0000 0000 | 10         | xx xxxx    |
| 3          | 0000 0000 | 11         | xx xxxx    |
| 4          | 0000 0001 | 00         | xx xxxx    |
| :          | :         | :          | :          |
| :          | :         | :          | :          |
| 254        | 0011 1111 | 10         | xx xxxx    |
| 255        | 0011 1111 | 11         | xx xxxx    |

"x": don't care

**HT66F2360 Erase Page Number and Selection**

| Erase Page | FARH      | FARL [7:6] | FARL [5:0] |
|------------|-----------|------------|------------|
| 0          | 0000 0000 | 00         | xx xxxx    |
| 1          | 0000 0000 | 01         | xx xxxx    |
| 2          | 0000 0000 | 10         | xx xxxx    |
| 3          | 0000 0000 | 11         | xx xxxx    |
| 4          | 0000 0001 | 00         | xx xxxx    |
| :          | :         | :          | :          |
| :          | :         | :          | :          |
| 510        | 0111 1111 | 10         | xx xxxx    |
| 511        | 0111 1111 | 11         | xx xxxx    |

"x": don't care

**HT66F2370 Erase Page Number and Selection**

| Erase Page | FARH      | FARL [7] | FARL [6:0] |
|------------|-----------|----------|------------|
| 0          | 0000 0000 | 0        | xxx xxxx   |
| 1          | 0000 0000 | 1        | xxx xxxx   |
| 2          | 0000 0001 | 0        | xxx xxxx   |
| 3          | 0000 0001 | 1        | xxx xxxx   |
| 4          | 0000 0010 | 0        | xxx xxxx   |
| :          | :         | :        | :          |
| :          | :         | :        | :          |
| 510        | 1111 1111 | 0        | xxx xxxx   |
| 511        | 1111 1111 | 1        | xxx xxxx   |

"x": don't care

**HT66F2390 Erase Page Number and Selection**

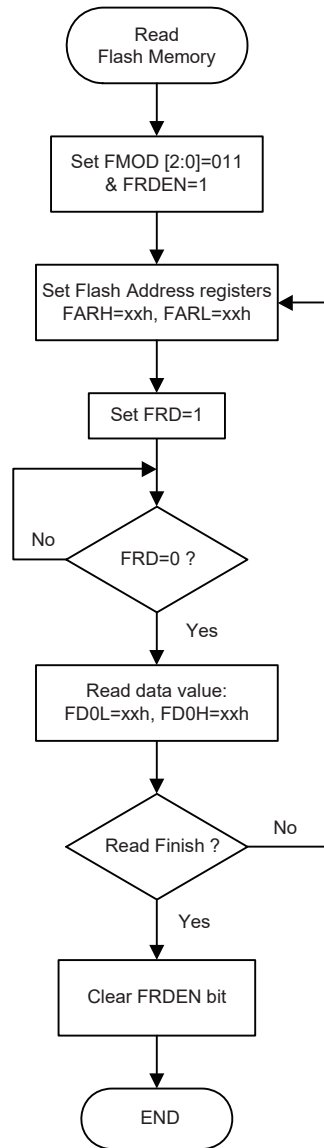

Read Flash Memory Procedure

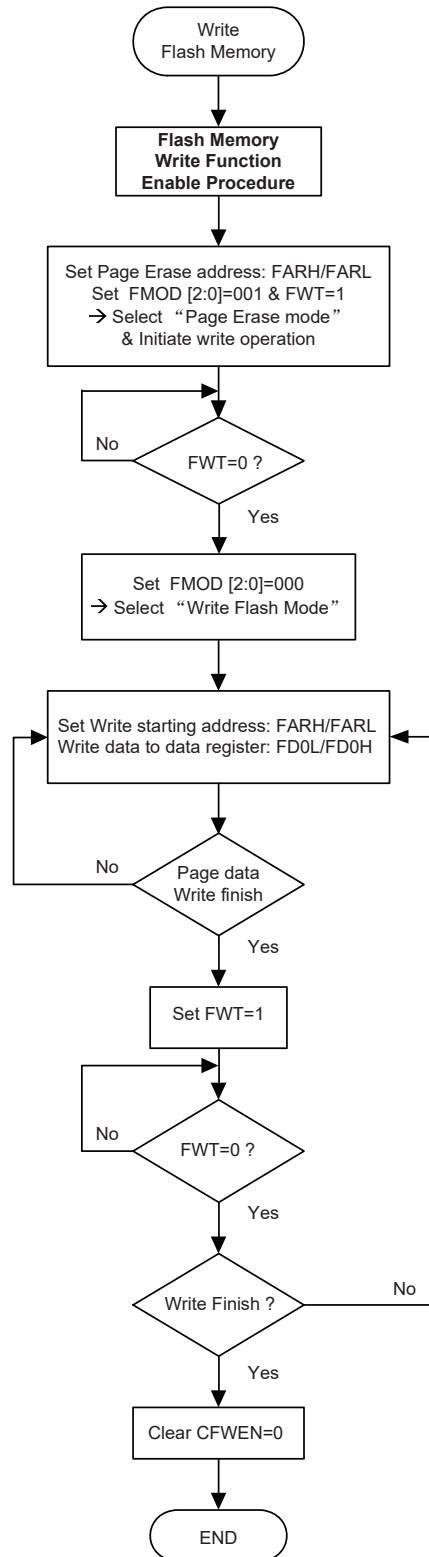

**Write Flash Memory Procedure**

Note: When the FWT or FRD bit is set to 1, the MCU is stopped.

## Data Memory

The Data Memory is an 8-bit wide RAM internal memory and is the location where temporary information is stored.

Divided into two types, the first of Data Memory is an area of RAM where special function registers are located. These registers have fixed locations and are necessary for correct operation of the device. Many of these registers can be read from and written to directly under program control, however, some remain protected from user manipulation. The second area of Data Memory is reserved for general purpose use. All locations within this area are read and write accessible under program control.

Switching between the different Data Memory sectors is achieved by properly setting the Memory Pointers to correct value.

### Structure

The Data Memory is subdivided into several sectors, all of which are implemented in 8-bit wide Memory. Each of the Data Memory sectors is categorized into two types, the Special Purpose Data Memory and the General Purpose Data Memory.

The address range of the Special Purpose Data Memory for the device is from 00H to 7FH while the General Purpose Data Memory address range is from 80H to FFH.

| Device    | Special Purpose Data Memory | General Purpose Data Memory |  |
|-----------|-----------------------------|-----------------------------|--|
|           | Sectors                     | Capacity                    | Sector : Address                             |
| HT66F2350 | 0, 1                        | 768×8                       | 0: 80H~FFH<br>1: 80H~FFH<br>:<br>5: 80H~FFH  |
| HT66F2360 | 0, 1                        | 1536×8                      | 0: 80H~FFH<br>1: 80H~FFH<br>:<br>11: 80H~FFH |
| HT66F2370 | 0, 1                        | 3072×8                      | 0: 80H~FFH<br>1: 80H~FFH<br>:<br>23: 80H~FFH |
| HT66F2390 | 0, 1                        | 4096×8                      | 0: 80H~FFH<br>1: 80H~FFH<br>:<br>31: 80H~FFH |

**Data Memory Summary**

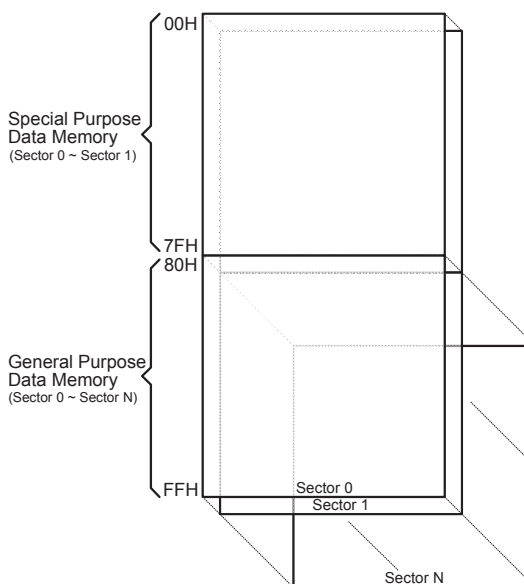

Note: N= 5 for HT66F2350;  
N=11 for HT66F2360;  
N=23 for HT66F2370;  
N=31 for HT66F2390

**Data Memory Structure**

## Data Memory Addressing

For these devices that support the extended instructions, there is no Bank Pointer for Data Memory. The Bank Pointer, PBP, is only available for Program Memory. For Data Memory the desired Sector is pointed by the MP1H or MP2H register and the certain Data Memory address in the selected sector is specified by the MP1L or MP2L register when using indirect addressing access.

Direct Addressing can be used in all sectors using the corresponding instruction which can address all available data memory space. For the accessed data memory which is located in any data memory sectors except sector 0, the extended instructions can be used to access the data memory instead of using the indirect addressing access. The main difference between standard instructions and extended instructions is that the data memory address "m" in the extended instructions can be from 11 bits to 13 bits depending upon which device is selected, the high byte indicates a sector and the low byte indicates a specific address.

## General Purpose Data Memory

All microcontroller programs require an area of read/write memory where temporary data can be stored and retrieved for use later. It is this area of RAM memory that is known as General Purpose Data Memory. This area of Data Memory is fully accessible by the user programming for both reading and writing operations. By using the bit operation instructions individual bits can be set or reset under program control giving the user a large range of flexibility for bit manipulation in the Data Memory.

## Special Purpose Data Memory

This area of Data Memory is where registers, necessary for the correct operation of the microcontroller, are stored. Most of the registers are both readable and writable but some are protected and are readable only, the details of which are located under the relevant Special Function Register section. Note that for locations that are unused, any read instruction to these addresses will return the value "00H".

|     | Sector 0 | Sector 1 |     | Sector 0   | Sector 1 |
|-----|----------|----------|-----|------------|----------|
| 00H | IAR0     | CRCCR    | 40H | LVDC       | EEC      |
| 01H | MP0      | CRCIN    | 41H | EEA        |          |
| 02H | IAR1     | CRCDL    | 42H |            |          |
| 03H | MP1L     | CRCDH    | 43H | EED        | FC0      |
| 04H | MP1H     |          | 44H | CP0C       | FC1      |
| 05H | ACC      |          | 45H | CP1C       | FC2      |
| 06H | PCL      | IECC     | 46H | PTM0C0     |          |
| 07H | TBLP     |          | 47H | PTM0C1     |          |
| 08H | TBLH     |          | 48H | PTM0DL     | IFS0     |
| 09H | TBHP     |          | 49H | PTM0DH     | IFS1     |
| 0AH | STATUS   |          | 4AH | PTM0AL     | IFS2     |
| 0BH |          |          | 4BH | PTM0AH     | IFS3     |
| 0CH | IAR2     |          | 4CH | PTM0RPL    |          |
| 0DH | MP2L     |          | 4DH | PTM0RPH    | PAS0     |
| 0EH | MP2H     |          | 4EH | STM0C0     | PAS1     |
| 0FH | RSTFC    |          | 4FH | STM0C1     | PBS0     |
| 10H | INTC0    | U0SR     | 50H | STM0DL     | PBS1     |
| 11H | INTC1    | U0CR1    | 51H | STM0DH     | PCS0     |
| 12H | INTC2    | U0CR2    | 52H | STM0AL     | PCS1     |
| 13H | INTC3    | TXR_RXR0 | 53H | STM0AH     | PDS0     |
| 14H | PA       | BRG0     | 54H | STM0RP     | PDS1     |
| 15H | PAC      | U1SR     | 55H | SLEDC0     | PES0     |
| 16H | PAPU     | U1CR1    | 56H | SLEDC1     | PES1     |
| 17H | PAWU     | U1CR2    | 57H | SLEDC2     | PFS0     |
| 18H | PB       | TXR_RXR1 | 58H |            | PFS1     |
| 19H | PBC      | BRG1     | 59H | MDUWR0     |          |
| 1AH | PBPU     | PTM1C0   | 5AH | MDUWR1     |          |
| 1BH | PC       | PTM1C1   | 5BH | MDUWR2     |          |
| 1CH | PCC      | PTM1DL   | 5CH | MDUWR3     |          |
| 1DH | PCPU     | PTM1DH   | 5DH | MDUWR4     |          |
| 1EH | PD       | PTM1AL   | 5EH | MDUWR5     |          |
| 1FH | PDC      | PTM1AH   | 5FH | MDUWCTRL   |          |
| 20H | PDPU     | PTM1RPL  | 60H | CP0VOS     |          |
| 21H | PE       | PTM1RPH  | 61H | CP1VOS     |          |
| 22H | PEC      | PTM2C0   | 62H |            |          |
| 23H | PEPU     | PTM2C1   | 63H | PSC0R      |          |
| 24H | PF       | PTM2DL   | 64H | TB0C       |          |
| 25H | PFC      | PTM2DH   | 65H | TB1C       |          |
| 26H | PFPU     | PTM2AL   | 66H | PSC1R      |          |
| 27H |          | PTM2AH   | 67H | SAD0L      |          |
| 28H |          | PTM2RPL  | 68H | SAD0H      |          |
| 29H |          | PTM2RPH  | 69H | SADC0      |          |
| 2AH |          | PTM3C0   | 6AH | SADC1      |          |
| 2BH |          | PTM3C1   | 6BH | SADC2      |          |
| 2CH |          | PTM3DL   | 6CH | SIMC0      |          |
| 2DH | PMPS     | PTM3DH   | 6DH | SIMC1      |          |
| 2EH | RSTC     | PTM3AL   | 6EH | SIMD       |          |
| 2FH | VBGRC    | PTM3AH   | 6FH | SIMA/SIMC2 |          |
| 30H |          | PTM3RPL  | 70H | SIMTOC     |          |
| 31H |          | PTM3RPH  | 71H | SPIAC0     |          |
| 32H |          | STM1C0   | 72H | SPIAC1     |          |
| 33H | MF10     | STM1C1   | 73H | SPIAD      |          |
| 34H | MF11     | STM1DL   | 74H | FARL       |          |
| 35H | MF12     | STM1DH   | 75H | FARH       |          |
| 36H | MF13     | STM1AL   | 76H | FD0L       |          |
| 37H | MF14     | STM1AH   | 77H | FD0H       |          |
| 38H | MF15     | STM1RP   | 78H | FD1L       |          |
| 39H | INTEG    | STM2C0   | 79H | FD1H       |          |
| 3AH | SCC      | STM2C1   | 7AH | FD2L       |          |
| 3BH | HIRCC    | STM2DL   | 7BH | FD2H       |          |
| 3CH | HXTC     | STM2DH   | 7CH | FD3L       |          |
| 3DH | LXTC     | STM2AL   | 7DH | FD3H       |          |
| 3EH | WDTC     | STM2AH   | 7EH |            |          |
| 3FH | LVRC     | STM2RP   | 7FH | SCOMC      |          |

■ : Unused, read as 00H

**Special Purpose Data Memory Structure – HT66F2350**

|     | Sector 0 | Sector 1 |     | Sector 0   | Sector 1 |
|-----|----------|----------|-----|------------|----------|
| 00H | IAR0     | CRCCR    | 40H | LVDC       | EEC      |
| 01H | MP0      | CRCIN    | 41H | EEA        |          |
| 02H | IAR1     | CRCDL    | 42H |            |          |
| 03H | MP1L     | CRCDH    | 43H | EED        | FC0      |
| 04H | MP1H     |          | 44H | CP0C       | FC1      |
| 05H | ACC      |          | 45H | CP1C       | FC2      |
| 06H | PCL      | IECC     | 46H | PTM0C0     |          |
| 07H | TBLP     |          | 47H | PTM0C1     |          |
| 08H | TBLH     |          | 48H | PTM0DL     | IFS0     |
| 09H | TBHP     |          | 49H | PTM0DH     | IFS1     |
| 0AH | STATUS   |          | 4AH | PTM0AL     | IFS2     |
| 0BH | PBP      |          | 4BH | PTM0AH     | IFS3     |
| 0CH | IAR2     |          | 4CH | PTMORPL    |          |
| 0DH | MP2L     |          | 4DH | PTMORPH    | PAS0     |
| 0EH | MP2H     |          | 4EH | STM0C0     | PAS1     |
| 0FH | RSTFC    |          | 4FH | STM0C1     | PBS0     |
| 10H | INTC0    | U0SR     | 50H | STM0DL     | PBS1     |
| 11H | INTC1    | U0CR1    | 51H | STM0DH     | PCS0     |
| 12H | INTC2    | U0CR2    | 52H | STM0AL     | PCS1     |
| 13H | INTC3    | TXR_RXR0 | 53H | STM0AH     | PDS0     |
| 14H | PA       | BRG0     | 54H | STM0RP     | PDS1     |
| 15H | PAC      | U1SR     | 55H | SLEDC0     | PES0     |
| 16H | PAPU     | U1CR1    | 56H | SLEDC1     | PES1     |
| 17H | PAWU     | U1CR2    | 57H | SLEDC2     | PFS0     |
| 18H | PB       | TXR_RXR1 | 58H | SLEDC3     | PFS1     |
| 19H | PBC      | BRG1     | 59H | MDUWR0     | PGS0     |
| 1AH | PBPU     | PTM1C0   | 5AH | MDUWR1     | PGS1     |
| 1BH | PC       | PTM1C1   | 5BH | MDUWR2     | PHS0     |
| 1CH | PCC      | PTM1DL   | 5CH | MDUWR3     | PHS1     |
| 1DH | PCPU     | PTM1DH   | 5DH | MDUWR4     |          |
| 1EH | PD       | PTM1AL   | 5EH | MDUWR5     |          |
| 1FH | PDC      | PTM1AH   | 5FH | MDUWCTRL   |          |
| 20H | PDPU     | PTM1RPL  | 60H | CP0VOS     |          |
| 21H | PE       | PTM1RPH  | 61H | CP1VOS     |          |
| 22H | PEC      | PTM2C0   | 62H |            |          |
| 23H | PEPU     | PTM2C1   | 63H | PSC0R      |          |
| 24H | PF       | PTM2DL   | 64H | TB0C       |          |
| 25H | PFC      | PTM2DH   | 65H | TB1C       |          |
| 26H | PFPU     | PTM2AL   | 66H | PSC1R      |          |
| 27H | PG       | PTM2AH   | 67H | SADOL      |          |
| 28H | PGC      | PTM2RPL  | 68H | SADOH      |          |
| 29H | PGPU     | PTM2RPH  | 69H | SADC0      |          |
| 2AH | PH       | PTM3C0   | 6AH | SADC1      |          |
| 2BH | PHC      | PTM3C1   | 6BH | SADC2      |          |
| 2CH | PHPU     | PTM3DL   | 6CH | SIMC0      |          |
| 2DH | PMP5     | PTM3DH   | 6DH | SIMC1      |          |
| 2EH | RSTC     | PTM3AL   | 6EH | SIMD       |          |
| 2FH | VBGRC    | PTM3AH   | 6FH | SIMA/SIMC2 |          |
| 30H |          | PTM3RPL  | 70H | SIMTOC     |          |
| 31H |          | PTM3RPH  | 71H | SPIAC0     |          |
| 32H |          | STM1C0   | 72H | SPIAC1     |          |
| 33H | MF10     | STM1C1   | 73H | SPIAD      |          |
| 34H | MF11     | STM1DL   | 74H | FARL       |          |
| 35H | MF12     | STM1DH   | 75H | FARH       |          |
| 36H | MF13     | STM1AL   | 76H | FD0L       |          |
| 37H | MF14     | STM1AH   | 77H | FD0H       |          |
| 38H | MF15     | STM1RP   | 78H | FD1L       |          |
| 39H | INTEG    | STM2C0   | 79H | FD1H       |          |
| 3AH | SCC      | STM2C1   | 7AH | FD2L       |          |
| 3BH | HIRCC    | STM2DL   | 7BH | FD2H       |          |
| 3CH | HXTC     | STM2DH   | 7CH | FD3L       |          |
| 3DH | LXTC     | STM2AL   | 7DH | FD3H       |          |
| 3EH | WDTC     | STM2AH   | 7EH |            |          |
| 3FH | LVRC     | STM2RP   | 7FH | SCOMC      |          |

■ : Unused, read as 00H

**Special Purpose Data Memory Structure – HT66F2360**

|     | Sector 0 | Sector 1 |     | Sector 0   | Sector 1 |
|-----|----------|----------|-----|------------|----------|
| 00H | IAR0     | CRCCR    | 40H | LVDC       | EEC      |
| 01H | MP0      | CRCIN    | 41H | EEAL       |          |
| 02H | IAR1     | CRCDL    | 42H | EEAH       |          |
| 03H | MP1L     | CRCDH    | 43H | EED        | FC0      |
| 04H | MP1H     |          | 44H | CP0C       | FC1      |
| 05H | ACC      |          | 45H | CP1C       | FC2      |
| 06H | PCL      | IECC     | 46H | PTM0C0     |          |
| 07H | TBLP     |          | 47H | PTM0C1     |          |
| 08H | TBLH     |          | 48H | PTM0DL     | IFS0     |
| 09H | TBHP     |          | 49H | PTM0DH     | IFS1     |
| 0AH | STATUS   |          | 4AH | PTM0AL     | IFS2     |
| 0BH | PBP      | U2SR     | 4BH | PTM0AH     | IFS3     |
| 0CH | IAR2     | U2CR1    | 4CH | PTM0RPL    |          |
| 0DH | MP2L     | U2CR2    | 4DH | PTM0RPH    | PAS0     |
| 0EH | MP2H     | TXR_RXR2 | 4EH | STM0C0     | PAS1     |
| 0FH | RSTFC    | BRG2     | 4FH | STM0C1     | PBS0     |
| 10H | INTC0    | U0SR     | 50H | STM0DL     | PBS1     |
| 11H | INTC1    | U0CR1    | 51H | STM0DH     | PCS0     |
| 12H | INTC2    | U0CR2    | 52H | STM0AL     | PCS1     |
| 13H | INTC3    | TXR_RXR0 | 53H | STM0AH     | PDS0     |
| 14H | PA       | BRG0     | 54H | STM0RP     | PDS1     |
| 15H | PAC      | U1SR     | 55H | SLEDC0     | PES0     |
| 16H | PAPU     | U1CR1    | 56H | SLEDC1     | PES1     |
| 17H | PAWU     | U1CR2    | 57H | SLEDC2     | PFS0     |
| 18H | PB       | TXR_RXR1 | 58H | SLEDC3     | PFS1     |
| 19H | PBC      | BRG1     | 59H | MDUWR0     | PGS0     |
| 1AH | PBPU     | PTM1C0   | 5AH | MDUWR1     | PGS1     |
| 1BH | PC       | PTM1C1   | 5BH | MDUWR2     | PHS0     |
| 1CH | PCC      | PTM1DL   | 5CH | MDUWR3     | PHS1     |
| 1DH | PCPU     | PTM1DH   | 5DH | MDUWR4     |          |
| 1EH | PD       | PTM1AL   | 5EH | MDUWR5     |          |
| 1FH | PDC      | PTM1AH   | 5FH | MDUWCTRL   |          |
| 20H | PDPU     | PTM1RPL  | 60H | CP0VOS     |          |
| 21H | PE       | PTM1RPH  | 61H | CP1VOS     |          |
| 22H | PEC      | PTM2C0   | 62H |            |          |
| 23H | PEPU     | PTM2C1   | 63H | PSC0R      |          |
| 24H | PF       | PTM2DL   | 64H | TB0C       |          |
| 25H | PFC      | PTM2DH   | 65H | TB1C       |          |
| 26H | PFFU     | PTM2AL   | 66H | PSC1R      |          |
| 27H | PG       | PTM2AH   | 67H | SAD0L      |          |
| 28H | PGC      | PTM2RPL  | 68H | SAD0H      |          |
| 29H | PGPU     | PTM2RPH  | 69H | SADC0      |          |
| 2AH | PH       | PTM3C0   | 6AH | SADC1      |          |
| 2BH | PHC      | PTM3C1   | 6BH | SADC2      |          |
| 2CH | PHPU     | PTM3DL   | 6CH | SIMC0      | ≈        |
| 2DH | PMPS     | PTM3DH   | 6DH | SIMC1      | ≈        |
| 2EH | RSTC     | PTM3AL   | 6EH | SIMD       |          |
| 2FH | VBGRC    | PTM3AH   | 6FH | SIMA/SIMC2 |          |
| 30H |          | PTM3RPL  | 70H | SIMTOC     |          |
| 31H |          | PTM3RPH  | 71H | SPIAC0     |          |
| 32H |          | STM1C0   | 72H | SPIAC1     |          |
| 33H | MF10     | STM1C1   | 73H | SPIAD      |          |
| 34H | MF11     | STM1DL   | 74H | FARL       |          |
| 35H | MF12     | STM1DH   | 75H | FARH       |          |
| 36H | MF13     | STM1AL   | 76H | FD0L       |          |
| 37H | MF14     | STM1AH   | 77H | FD0H       |          |
| 38H | MF15     | STM1RP   | 78H | FD1L       |          |
| 39H | INTEG    | STM2C0   | 79H | FD1H       |          |
| 3AH | SCC      | STM2C1   | 7AH | FD2L       |          |
| 3BH | HIRCC    | STM2DL   | 7BH | FD2H       |          |
| 3CH | HXTC     | STM2DH   | 7CH | FD3L       |          |
| 3DH | LXTC     | STM2AL   | 7DH | FD3H       |          |
| 3EH | WDTC     | STM2AH   | 7EH |            |          |
| 3FH | LVRC     | STM2RP   | 7FH | SCOMC      |          |

◻ : Unused, read as 00H

**Special Purpose Data Memory Structure – HT66F2370/HT66F2390**

## Special Function Register Description

Most of the Special Function Register details will be described in the relevant functional section. However, several registers require a separate description in this section.

### Indirect Addressing Registers – IAR0, IAR1, IAR2

The Indirect Addressing Registers, IAR0, IAR1 and IAR2, although having their locations in normal RAM register space, do not actually physically exist as normal registers. The method of indirect addressing for RAM data manipulation uses these Indirect Addressing Registers and Memory Pointers, in contrast to direct memory addressing, where the actual memory address is specified. Actions on the IAR0, IAR1 and IAR2 registers will result in no actual read or write operation to these registers but rather to the memory location specified by their corresponding Memory Pointers, MP0, MP1L/MP1H or MP2L/MP2H. Acting as a pair, IAR0 and MP0 can together access data only from Sector 0 while the IAR1 register together with MP1L/MP1H register pair and IAR2 register together with MP2L/MP2H register pair can access data from any Data Memory sector. As the Indirect Addressing Registers are not physically implemented, reading the Indirect Addressing Registers indirectly will return a result of "00H" and writing to the registers indirectly will result in no operation.

### Memory Pointers – MP0, MP1H/MP1L, MP2H/MP2L

Five Memory Pointers, known as MP0, MP1L, MP1H, MP2L and MP2H, are provided. These Memory Pointers are physically implemented in the Data Memory and can be manipulated in the same way as normal registers providing a convenient way with which to address and track data. When any operation to the relevant Indirect Addressing Registers is carried out, the actual address that the microcontroller is directed to is the address specified by the related Memory Pointer. MP0, together with Indirect Addressing Register, IAR0, are used to access data from Sector 0, while MP1L/MP1H together with IAR1 and MP2L/MP2H together with IAR2 are used to access data from all data sectors according to the corresponding MP1H or MP2H register. Direct Addressing can be used in all data sectors using the corresponding instruction which can address all available data memory space.

### Indirect Addressing Program Example

- **Example 1**

```
data .section 'data'
adres1 db ?
adres2 db ?
adres3 db ?
adres4 db ?
block db ?
code .section at 0 code
org 00h
start:
mov a,04h           ; setup size of block
mov block,a
mov a,offset adres1 ; Accumulator loaded with first RAM address
mov mp0,a          ; setup memory pointer with first RAM address
loop:
clr IAR0           ; clear the data at address defined by MP0
inc mp0           ; increment memory pointer
sdz block         ; check if last memory location has been cleared
jmp loop
continue:
:
```

• **Example 2**

```

data .section 'data'
adres1 db ?
adres2 db ?
adres3 db ?
adres4 db ?
block db ?
code .section at 0 'code'
org 00h
start:
mov a,04h                ; setup size of block
mov block,a
mov a,01h                ; setup the memory sector
mov mplh,a
mov a,offset adres1     ; Accumulator loaded with first RAM address
mov mp1l,a               ; setup memory pointer with first RAM address
loop:
clr IAR1                 ; clear the data at address defined by MP1L
inc mp1l                 ; increment memory pointer MP1L
sdz block                ; check if last memory location has been cleared
jmp loop
continue:
:
```

The important point to note here is that in the example shown above, no reference is made to specific RAM addresses.

**Direct Addressing Program Example using extended instructions**

```

data .section 'data'
temp db ?
code .section at 0 code
org 00h
start:
lmov a,[m]               ; move [m] data to acc
lsub a, [m+1]            ; compare [m] and [m+1] data
snz c                    ; [m]>[m+1]?
jmp continue            ; no
lmov a,[m]               ; yes, exchange [m] and [m+1] data
mov temp,a
lmov a,[m+1]
lmov [m],a
mov a,temp
lmov [m+1],a
continue:
:
```

Note: Here "m" is a data memory address located in any data memory sectors. For example, m=1F0H, it indicates address 0F0H in Sector 1.

## Program Memory Bank Pointer – PBP

For the series of devices the Program Memory is divided into several banks except for the HT66F2350 device. Selecting the required Program Memory area is achieved using the Program Memory Bank Pointer, PBP. The PBP register should be properly configured before the device executes the "Branch" operation using the "JMP" or "CALL" instruction. After that a jump to a non-consecutive Program Memory address which is located in a certain bank selected by the program memory bank pointer bits will occur.

### • PBP Register – HT66F2360

| Bit  | 7   | 6   | 5   | 4   | 3   | 2   | 1   | 0    |
|------|-----|-----|-----|-----|-----|-----|-----|------|
| Name | D7  | D6  | D5  | D4  | D3  | D2  | D1  | PBP0 |
| R/W  | R/W | R/W | R/W | R/W | R/W | R/W | R/W | R/W  |
| POR  | 0   | 0   | 0   | 0   | 0   | 0   | 0   | 0    |

Bit 7~1 **D7~D1**: General data bits and can be read or written.

Bit 0 **PBP0**: Program Memory Bank Point bit 0  
 0: Bank 0  
 1: Bank 1

### • PBP Register – HT66F2370

| Bit  | 7   | 6   | 5   | 4   | 3   | 2   | 1    | 0    |
|------|-----|-----|-----|-----|-----|-----|------|------|
| Name | D7  | D6  | D5  | D4  | D3  | D2  | PBP1 | PBP0 |
| R/W  | R/W | R/W | R/W | R/W | R/W | R/W | R/W  | R/W  |
| POR  | 0   | 0   | 0   | 0   | 0   | 0   | 0    | 0    |

Bit 7~2 **D7~D2**: General data bits and can be read or written.

Bit 1~0 **PBP1~PBP0**: Program Memory Bank Point bit 1 ~ bit 0  
 00: Bank 0  
 01: Bank 1  
 10: Bank 2  
 11: Bank 3

### • PBP Register – HT66F2390

| Bit  | 7   | 6   | 5   | 4   | 3   | 2    | 1    | 0    |
|------|-----|-----|-----|-----|-----|------|------|------|
| Name | D7  | D6  | D5  | D4  | D3  | PBP2 | PBP1 | PBP0 |
| R/W  | R/W | R/W | R/W | R/W | R/W | R/W  | R/W  | R/W  |
| POR  | 0   | 0   | 0   | 0   | 0   | 0    | 0    | 0    |

Bit 7~3 **D7~D3**: General data bits and can be read or written.

Bit 2~0 **PBP2~PBP0**: Program Memory Bank Point bit 2 ~ bit 0  
 000: Bank 0  
 001: Bank 1  
 010: Bank 2  
 011: Bank 3  
 100: Bank 4  
 101: Bank 5  
 110: Bank 6  
 111: Bank 7

### **Accumulator – ACC**

The Accumulator is central to the operation of any microcontroller and is closely related with operations carried out by the ALU. The Accumulator is the place where all intermediate results from the ALU are stored. Without the Accumulator it would be necessary to write the result of each calculation or logical operation such as addition, subtraction, shift, etc., to the Data Memory resulting in higher programming and timing overheads. Data transfer operations usually involve the temporary storage function of the Accumulator; for example, when transferring data between one user-defined register and another, it is necessary to do this by passing the data through the Accumulator as no direct transfer between two registers is permitted.

### **Program Counter Low Register – PCL**

To provide additional program control functions, the low byte of the Program Counter is made accessible to programmers by locating it within the Special Purpose area of the Data Memory. By manipulating this register, direct jumps to other program locations are easily implemented. Loading a value directly into this PCL register will cause a jump to the specified Program Memory location; however, as the register is only 8-bit wide, only jumps within the current Program Memory page are permitted. When such operations are used, note that a dummy cycle will be inserted.

### **Look-up Table Registers – TBLP, TBHP, TBLH**

These three special function registers are used to control operation of the look-up table which is stored in the Program Memory. The TBLP and TBHP registers are the table pointer pair and indicates the location where the table data is located. Their value must be setup before any table read instructions are executed. Their value can be changed, for example using the "INC" or "DEC" instructions, allowing for easy table data pointing and reading. TBLH is the location where the high order byte of the table data is stored after a table read data instruction has been executed. Note that the lower order table data byte is transferred to a user defined location.

## Status Register – STATUS

This 8-bit register contains the zero flag (Z), carry flag (C), auxiliary carry flag (AC), overflow flag (OV), SC flag, CZ flag, power down flag (PDF), and watchdog time-out flag (TO). These arithmetic/logical operation and system management flags are used to record the status and operation of the microcontroller.

With the exception of the TO and PDF flags, bits in the status register can be altered by instructions like most other registers. Any data written into the status register will not change the TO or PDF flag. In addition, operations related to the status register may give different results due to the different instruction operations. The TO flag can be affected only by a system power-up, a WDT time-out or by executing the "CLR WDT" or "HALT" instruction. The PDF flag is affected only by executing the "HALT" or "CLR WDT" instruction or during a system power-up.

The Z, OV, AC, C, SC and CZ flags generally reflect the status of the latest operations.

- C is set if an operation results in a carry during an addition operation or if a borrow does not take place during a subtraction operation; otherwise C is cleared. C is also affected by a rotate through carry instruction.
- AC is set if an operation results in a carry out of the low nibbles in addition, or no borrow from the high nibble into the low nibble in subtraction; otherwise AC is cleared.
- Z is set if the result of an arithmetic or logical operation is zero; otherwise Z is cleared.
- OV is set if an operation results in a carry into the highest-order bit but not a carry out of the highest-order bit, or vice versa; otherwise OV is cleared.
- PDF is cleared by a system power-up or executing the "CLR WDT" instruction. PDF is set by executing the "HALT" instruction.
- TO is cleared by a system power-up or executing the "CLR WDT" or "HALT" instruction. TO is set by a WDT time-out.
- SC is the result of the "XOR" operation which is performed by the OV flag and the MSB of the current instruction operation result.
- CZ is the operational result of different flags for different instructions. Refer to register definitions for more details.

In addition, on entering an interrupt sequence or executing a subroutine call, the status register will not be pushed onto the stack automatically. If the contents of the status registers are important and if the subroutine can corrupt the status register, precautions must be taken to correctly save it.

• **STATUS Register**

| Bit  | 7  | 6  | 5  | 4   | 3   | 2   | 1   | 0   |
|------|----|----|----|-----|-----|-----|-----|-----|
| Name | SC | CZ | TO | PDF | OV  | Z   | AC  | C   |
| R/W  | R  | R  | R  | R   | R/W | R/W | R/W | R/W |
| POR  | x  | x  | 0  | 0   | x   | x   | x   | x   |

"x": unknown

- Bit 7      **SC**: The result of the "XOR" operation which is performed by the OV flag and the MSB of the instruction operation result.
- Bit 6      **CZ**: The operational result of different flags for different instructions.  
 For SUB/SUBM/LSUB/LSUBM instructions, the CZ flag is equal to the Z flag.  
 For SBC/ SBCM/ LSBC/ LSBCM instructions, the CZ flag is the "AND" operation result which is performed by the previous operation CZ flag and current operation zero flag. For other instructions, the CZ flag will not be affected.
- Bit 5      **TO**: Watchdog Time-out flag  
 0: After power up or executing the "CLR WDT" or "HALT" instruction  
 1: A watchdog time-out occurred
- Bit 4      **PDF**: Power down flag  
 0: After power up or executing the "CLR WDT" instruction  
 1: By executing the "HALT" instruction
- Bit 3      **OV**: Overflow flag  
 0: No overflow  
 1: An operation results in a carry into the highest-order bit but not a carry out of the highest-order bit or vice versa
- Bit 2      **Z**: Zero flag  
 0: The result of an arithmetic or logical operation is not zero  
 1: The result of an arithmetic or logical operation is zero
- Bit 1      **AC**: Auxiliary flag  
 0: No auxiliary carry  
 1: An operation results in a carry out of the low nibbles, in addition, or no borrow from the high nibble into the low nibble in subtraction
- Bit 0      **C**: Carry flag  
 0: No carry-out  
 1: An operation results in a carry during an addition operation or if a borrow does not take place during a subtraction operation  
 The "C" flag is also affected by a rotate through carry instruction.

## EEPROM Data Memory

These devices contain an area of internal EEPROM Data Memory. EEPROM, which stands for Electrically Erasable Programmable Read Only Memory, is by its nature a non-volatile form of re-programmable memory, with data retention even when its power supply is removed. By incorporating this kind of data memory, a whole new host of application possibilities are made available to the designer. The availability of EEPROM storage allows information such as product identification numbers, calibration values, specific user data, system setup data or other product information to be stored directly within the product microcontroller. The process of reading and writing data to the EEPROM memory has been reduced to a very trivial affair.

| Device    | Capacity | Address     |
|-----------|----------|-------------|
| HT66F2350 | 256×8    | 00H ~ FFH   |
| HT66F2360 |          |             |
| HT66F2370 | 512×8    | 000H ~ 1FFH |
| HT66F2390 | 1024×8   | 000H ~ 3FFH |

### EEPROM Data Memory Structure

The EEPROM Data Memory capacity is up to 1024×8 bits for the series of devices. Unlike the Program Memory and RAM Data Memory, the EEPROM Data Memory is not directly mapped into memory space and is therefore not directly addressable in the same way as the other types of memory. Read and Write operations to the EEPROM are carried out in single byte operations using an address and data register in sector 0 and a single control register in sector 1.

### EEPROM Registers

Three registers control the overall operation of the internal EEPROM Data Memory. These are the address register, EEA, the data register, EED and a single control register, EEC. As both the EEA and EED registers are located in sector 0, they can be directly accessed in the same way as any other Special Function Register. The EEC register, however, being located in sector 1, can be read from or written to indirectly using the MP1H/MP1L or MP2H/MP2L Memory Pointer pair and Indirect Addressing Register, IAR1 or IAR2. Because the EEC control register is located at address 40H in sector 1, the Memory Pointer low byte register, MP1L or MP2L, must first be set to the value 40H and the Memory Pointer high byte register, MP1H or MP2H, set to the value, 01H, before any operations on the EEC register are executed.

| Register Name       | Bit   |       |       |       |       |       |       |       |
|---------------------|-------|-------|-------|-------|-------|-------|-------|-------|
|                     | 7     | 6     | 5     | 4     | 3     | 2     | 1     | 0     |
| EEA (HT66F2350/60)  | EEA7  | EEA6  | EEA5  | EEA4  | EEA3  | EEA2  | EEA1  | EEA0  |
| EEAL (HT66F2370/90) | EEAL7 | EEAL6 | EEAL5 | EEAL4 | EEAL3 | EEAL2 | EEAL1 | EEAL0 |
| EEAH (HT66F2370)    | —     | —     | —     | —     | —     | —     | —     | EEAH0 |
| EEAH (HT66F2390)    | —     | —     | —     | —     | —     | —     | EEAH1 | EEAH0 |
| EED                 | D7    | D6    | D5    | D4    | D3    | D2    | D1    | D0    |
| EEC                 | —     | —     | —     | —     | WREN  | WR    | RDEN  | RD    |

EEPROM Registers List

• **EAA Register – HT66F2350/HT66F2360**

| Bit  | 7    | 6    | 5    | 4    | 3    | 2    | 1    | 0    |
|------|------|------|------|------|------|------|------|------|
| Name | EEA7 | EEA6 | EEA5 | EEA4 | EEA3 | EEA2 | EEA1 | EEA0 |
| R/W  | R/W  | R/W  | R/W  | R/W  | R/W  | R/W  | R/W  | R/W  |
| POR  | 0    | 0    | 0    | 0    | 0    | 0    | 0    | 0    |

Bit 7~0      **EEA7~EEA0**: Data EEPROM address bit 7 ~ bit0

• **EEAL Register – HT66F2370/HT66F2390**

| Bit  | 7     | 6     | 5     | 4     | 3     | 2     | 1     | 0     |
|------|-------|-------|-------|-------|-------|-------|-------|-------|
| Name | EEAL7 | EEAL6 | EEAL5 | EEAL4 | EEAL3 | EEAL2 | EEAL1 | EEAL0 |
| R/W  | R/W   | R/W   | R/W   | R/W   | R/W   | R/W   | R/W   | R/W   |
| POR  | 0     | 0     | 0     | 0     | 0     | 0     | 0     | 0     |

Bit 7~0      **EEAL7~EEAL0**: Data EEPROM low byte address bit 7 ~ bit0

• **EEAH Register – HT66F2370**

| Bit  | 7 | 6 | 5 | 4 | 3 | 2 | 1 | 0     |
|------|---|---|---|---|---|---|---|-------|
| Name | — | — | — | — | — | — | — | EEAH0 |
| R/W  | — | — | — | — | — | — | — | R/W   |
| POR  | — | — | — | — | — | — | — | 0     |

Bit 7~1      Unimplemented, read as "0"

Bit 0      **EEAH0**: Data EEPROM high byte address bit 0

• **EEAH Register – HT66F2390**

| Bit  | 7 | 6 | 5 | 4 | 3 | 2 | 1     | 0     |
|------|---|---|---|---|---|---|-------|-------|
| Name | — | — | — | — | — | — | EEAH1 | EEAH0 |
| R/W  | — | — | — | — | — | — | R/W   | R/W   |
| POR  | — | — | — | — | — | — | 0     | 0     |

Bit 7~2      Unimplemented, read as "0"

Bit 1~0      **EEAH1~EEAH0**: Data EEPROM high byte address bit 1 ~ bit 0

• **EED Register**

| Bit  | 7   | 6   | 5   | 4   | 3   | 2   | 1   | 0   |
|------|-----|-----|-----|-----|-----|-----|-----|-----|
| Name | D7  | D6  | D5  | D4  | D3  | D2  | D1  | D0  |
| R/W  | R/W | R/W | R/W | R/W | R/W | R/W | R/W | R/W |
| POR  | 0   | 0   | 0   | 0   | 0   | 0   | 0   | 0   |

Bit 7~0      **D7~D0**: Data EEPROM data bit 7~bit0

• **EEC Register**

| Bit  | 7 | 6 | 5 | 4 | 3    | 2   | 1    | 0   |
|------|---|---|---|---|------|-----|------|-----|
| Name | — | — | — | — | WREN | WR  | RDEN | RD  |
| R/W  | — | — | — | — | R/W  | R/W | R/W  | R/W |
| POR  | — | — | — | — | 0    | 0   | 0    | 0   |

Bit 7~4 Unimplemented, read as "0"

Bit 3 **WREN**: Data EEPROM write enable

0: Disable

1: Enable

This is the Data EEPROM Write Enable Bit which must be set high before Data EEPROM write operations are carried out. Clearing this bit to zero will inhibit Data EEPROM write operations. Note that the WREN bit will automatically be cleared to zero after the write operation is finished.

Bit 2 **WR**: EEPROM write control

0: Write cycle has finished

1: Activate a write cycle

This is the Data EEPROM Write Control Bit and when set high by the application program will activate a write cycle. This bit will be automatically reset to zero by the hardware after the write cycle has finished. Setting this bit high will have no effect if the WREN has not first been set high.

Bit 1 **RDEN**: Data EEPROM read enable

0: Disable

1: Enable

This is the Data EEPROM Read Enable Bit which must be set high before Data EEPROM read operations are carried out. Clearing this bit to zero will inhibit Data EEPROM read operations.

Bit 0 **RD**: EEPROM read control

0: Read cycle has finished

1: Activate a read cycle

This is the Data EEPROM Read Control Bit and when set high by the application program will activate a read cycle. This bit will be automatically reset to zero by the hardware after the read cycle has finished. Setting this bit high will have no effect if the RDEN has not first been set high.

Note: The WREN, WR, RDEN and RD can not be set to "1" at the same time in one instruction. The WR and RD can not be set to "1" at the same time.

**Reading Data from the EEPROM**

To read data from the EEPROM, the EEPROM address of the data to be read must first be placed in the EEA register or EEAL/EEAH register pair. Then the read enable bit, RDEN, in the EEC register must be set high to enable the read function. If the RD bit in the EEC register is now set high, a read cycle will be initiated. Setting the RD bit high will not initiate a read operation if the RDEN bit has not been set. When the read cycle terminates, the RD bit will be automatically cleared to zero, after which the data can be read from the EED register. The data will remain in the EED register until another read or write operation is executed. The application program can poll the RD bit to determine when the data is valid for reading.

## Writing Data to the EEPROM

To write data to the EEPROM, the EEPROM address of the data to be written must first be placed in the EEA register or EEAL/EEAH register pair and the data placed in the EED register. To initiate a write cycle the write enable bit, WREN, in the EEC register must first be set high to enable the write function. After this, the WR bit in the EEC register must be immediately set high to initiate a write cycle successfully. These two instructions must be executed consecutively. The global interrupt bit EMI should also first be cleared before implementing any write operations, and then set high again after the write cycle has started. Note that setting the WR bit high will not initiate a write cycle if the WREN bit has not been set. As the EEPROM write cycle is controlled using an internal timer whose operation is asynchronous to microcontroller system clock, a certain time will elapse before the data will have been written into the EEPROM. Detecting when the write cycle has finished can be implemented either by polling the WR bit in the EEC register or by using the EEPROM interrupt. When the write cycle terminates, the WR bit will be automatically cleared to zero by the microcontroller, informing the user that the data has been written to the EEPROM. The application program can therefore poll the WR bit to determine when the write cycle has ended.

## Write Protection

Protection against inadvertent write operation is provided in several ways. After the device is powered on, the Write Enable bit in the control register will be cleared preventing any write operations. Also at power-on the Memory Pointer high byte register, MP1H or MP2H, will be reset to zero, which means that Data Memory sector 0 will be selected. As the EEPROM control register is located in sector 1, this adds a further measure of protection against spurious write operations. During normal program operation, ensuring that the Write Enable bit in the control register is cleared will safeguard against incorrect write operations.

## EEPROM Interrupt

The EEPROM write interrupt is generated when an EEPROM write cycle has ended. The EEPROM interrupt must first be enabled by setting the DEE bit in the relevant interrupt register. However, as the EEPROM is contained within a Multi-function Interrupt, the associated multi-function interrupt enable bit must also be set. When an EEPROM write cycle ends, the DEF request flag and its associated multi-function interrupt request flag will both be set. If the global, EEPROM and Multi-function interrupts are enabled and the stack is not full, a jump to the associated Multi-function Interrupt vector will take place. When the interrupt is serviced only the Multi-function interrupt flag will be automatically reset, the EEPROM interrupt flag must be manually reset by the application program.

## Programming Considerations

Care must be taken that data is not inadvertently written to the EEPROM. Protection can be Periodic by ensuring that the Write Enable bit is normally cleared to zero when not writing. Also the Memory Pointer high byte register could be normally cleared to zero as this would inhibit access to sector 1 where the EEPROM control register exist. Although certainly not necessary, consideration might be given in the application program to the checking of the validity of new write data by a simple read back process. When writing data the WR bit must be set high immediately after the WREN bit has been set high, to ensure the write cycle executes correctly. The global interrupt bit EMI should also be cleared before a write cycle is executed and then re-enabled after the write cycle starts. Note that the device should not enter the IDLE or SLEEP mode until the EEPROM read or write operation is totally complete. Otherwise, the EEPROM read or write operation will fail.

### Programming Example – for HT66F2350

#### Reading data from the EEPROM – polling method

```
MOV A, EEPROM_ADRES          ; user defined address
MOV EEA, A
MOV A, 040H                  ; setup memory pointer low byte MP1L
MOV MP1L, A                  ; MP1L points to EEC register
MOV A, 01H                   ; setup Memory Pointer high byte MP1H
MOV MP1H, A
SET IAR1.1                   ; set RDEN bit, enable read operations
SET IAR1.0                   ; start Read Cycle - set RD bit
BACK:
SZ IAR1.0                    ; check for read cycle end
JMP BACK
CLR IAR1                      ; disable EEPROM write
CLR MP1H
MOV A, EED                   ; move read data to register
MOV READ_DATA, A
```

#### Writing Data to the EEPROM – polling method

```
MOV A, EEPROM_ADRES          ; user defined address
MOV EEA, A
MOV A, EEPROM_DATA           ; user defined data
MOV EED, A
MOV A, 040H                  ; setup memory pointer low byte MP1L
MOV MP1L, A                  ; MP1L points to EEC register
MOV A, 01H                   ; setup Memory Pointer high byte MP1H
MOV MP1H, A
CLR EMI
SET IAR1.3                   ; set WREN bit, enable write operations
SET IAR1.2                   ; start Write Cycle - set WR bit
SET EMI
BACK:
SZ IAR1.2                    ; check for write cycle end
JMP BACK
CLR IAR1                      ; disable EEPROM write
CLR MP1H
```

## Oscillators

Various oscillator types offer the user a wide range of functions according to their various application requirements. The flexible features of the oscillator functions ensure that the best optimisation can be achieved in terms of speed and power saving. Oscillator selections and operation are selected through a combination of application program and relevant control registers.

### Oscillator Overview

In addition to being the source of the main system clock the oscillators also provide clock sources for the Watchdog Timer and Time Base Interrupts. External oscillators requiring some external components as well as fully integrated internal oscillators, requiring no external components, are provided to form a wide range of both fast and slow system oscillators. All oscillator options are selected through register programming. The higher frequency oscillators provide higher performance but carry with it the disadvantage of higher power requirements, while the opposite is of course true for the lower frequency oscillators. With the capability of dynamically switching between fast and slow system clock, the device has the flexibility to optimize the performance/power ratio, a feature especially important in power sensitive portable applications.

| Type                        | Name | Frequency    | Pins      |
|-----------------------------|------|--------------|-----------|
| External High Speed Crystal | HXT  | 400kHz~16MHz | OSC1/OSC2 |
| Internal High Speed RC      | HIRC | 8/12/16MHz   | —         |
| External Low Speed Crystal  | LXT  | 32.768kHz    | XT1/XT2   |
| Internal Low Speed RC       | LIRC | 32kHz        | —         |

**Oscillator Types**

### System Clock Configurations

There are four methods of generating the system clock, two high speed oscillators and two low speed oscillators for all devices. The high speed oscillator is the external crystal/ceramic oscillator, HXT, and the internal 8/12/16MHz RC oscillator, HIRC. The two low speed oscillators are the internal 32kHz RC oscillator, LIRC, and the external 32.768kHz crystal oscillator, LXT. Selecting whether the low or high speed oscillator is used as the system oscillator is implemented using the CKS2~CKS0 bits in the SCC register and as the system clock can be dynamically selected.

The actual source clock used for the low speed oscillators is chosen via the FSS bit in the SCC register while for the high speed oscillator the source clock is selected by the FHS bit in the SCC register. The frequency of the slow speed or high speed system clock is determined using the CKS2~CKS0 bits in the SCC register. Note that two oscillator selections must be made namely one high speed and one low speed system oscillators. It is not possible to choose a no-oscillator selection for either the high or low speed oscillator.

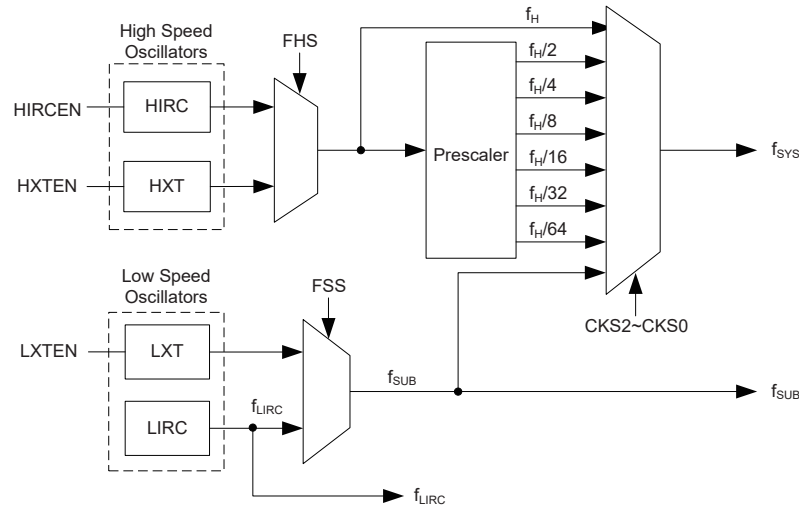

**System Clock Configurations**

**External Crystal/Ceramic Oscillator – HXT**

The External Crystal/Ceramic System Oscillator is the high frequency oscillator, which is the default oscillator clock source after power on. For most crystal oscillator configurations, the simple connection of a crystal across OSC1 and OSC2 will create the necessary phase shift and feedback for oscillation, without requiring external capacitors. However, for some crystal types and frequencies, to ensure oscillation, it may be necessary to add two small value capacitors, C1 and C2. Using a ceramic resonator will usually require two small value capacitors, C1 and C2, to be connected as shown for oscillation to occur. The values of C1 and C2 should be selected in consultation with the crystal or resonator manufacturer’s specification.

For oscillator stability and to minimise the effects of noise and crosstalk, it is important to ensure that the crystal and any associated resistors and capacitors along with interconnecting lines are all located as close to the MCU as possible.

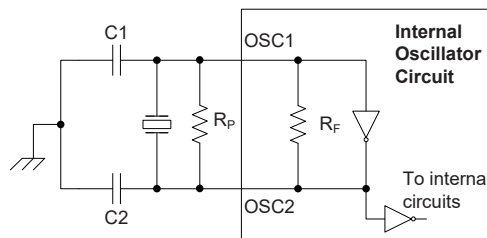

- Note: 1.  $R_p$  is normally not required. C1 and C2 are required.
- 2. Although not shown OSC1/OSC2 pins have a parasitic capacitance of around 7pF.

**Crystal/Resonator Oscillator**

| HXT Oscillator C1 and C2 Values |        |        |
|---------------------------------|--------|--------|
| Crystal Frequency               | C1     | C2     |
| 12MHz                           | 0 pF   | 0 pF   |
| 8MHz                            | 0 pF   | 0 pF   |
| 4MHz                            | 0 pF   | 0 pF   |
| 1MHz                            | 100 pF | 100 pF |

**Note:** C1 and C2 values are for guidance only.

**Crystal Recommended Capacitor Values**

### Internal High Speed RC Oscillator – HIRC

The internal RC oscillator is a fully integrated system oscillator requiring no external components. The internal RC oscillator has a fixed frequency of 8/12/16 MHz. Device trimming during the manufacturing process and the inclusion of internal frequency compensation circuits are used to ensure that the influence of the power supply voltage, temperature and process variations on the oscillation frequency are minimised. As a result, at a power supply of 3V or 5V and at a temperature of 25°C degrees, the selected trimmed oscillation frequency will have a tolerance within 1%. Note that if this internal system clock is selected, as it requires no external pins for its operation, I/O pins are free for use as normal I/O pins or other pin-shared functional pins.

### External 32.768kHz Crystal Oscillator – LXT

The External 32.768kHz Crystal System Oscillator is one of the low frequency oscillator choices, which is selected via a software control bit, FSS. This clock source has a fixed frequency of 32.768kHz and requires a 32.768kHz crystal to be connected between pins XT1 and XT2. The external resistor and capacitor components connected to the 32.768kHz crystal are necessary to provide oscillation. For applications where precise frequencies are essential, these components may be required to provide frequency compensation due to different crystal manufacturing tolerances. After the LXT oscillator is enabled by setting the LXTEN bit to 1, there is a time delay associated with the LXT oscillator waiting for it to start-up.

When the microcontroller enters the SLEEP or IDLE Mode, the system clock is switched off to stop microcontroller activity and to conserve power. However, in many microcontroller applications it may be necessary to keep the internal timers operational even when the microcontroller is in the SLEEP or IDLE Mode. To do this, another clock, independent of the system clock, must be provided.

However, for some crystals, to ensure oscillation and accurate frequency generation, it is necessary to add two small value external capacitors, C1 and C2. The exact values of C1 and C2 should be selected in consultation with the crystal or resonator manufacturer’s specification. The external parallel feedback resistor, R<sub>p</sub>, and the pull high resistor, R<sub>u</sub>, are required.

The pin-shared software control bits determine if the XT1/XT2 pins are used for the LXT oscillator or as I/O or other pin-shared functional pins.

- If the LXT oscillator is not used for any clock source, the XT1/XT2 pins can be used as normal I/O or other pin-shared functional pins.
- If the LXT oscillator is used for any clock source, the 32.768kHz crystal should be connected to the XT1/XT2 pins.

For oscillator stability and to minimise the effects of noise and crosstalk, it is important to ensure that the crystal and any associated resistors and capacitors along with interconnecting lines are all located as close to the MCU as possible.

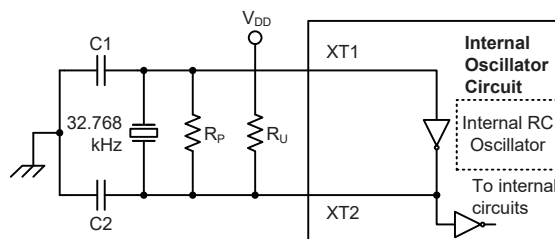

- Note: 1. R<sub>p</sub>, R<sub>u</sub>, C1 and C2 are required.  
 2. Although not shown XT1/XT2 pins have a parasitic capacitance of around 7pF.

**External LXT Oscillator**

| LXT Oscillator C1 and C2 Values |      |      |
|---------------------------------|------|------|
| Crystal Frequency               | C1   | C2   |
| 32.768kHz                       | 10pF | 10pF |

Note: 1. C1 and C2 values are for guidance only.  
2.  $R_P=5M\sim 10M\Omega$  is recommended.  
3.  $R_U=10M\Omega$  is recommended.

**32.768kHz Crystal Recommended Capacitor Values**

### Internal 32kHz Oscillator – LIRC

The Internal 32 kHz System Oscillator is one of the low frequency oscillator choices, which is selected via a software control bit, FSS. It is a fully integrated RC oscillator with a typical frequency of 32 kHz at 5V, requiring no external components for its implementation. Device trimming during the manufacturing process and the inclusion of internal frequency compensation circuits are used to ensure that the influence of the power supply voltage, temperature and process variations on the oscillation frequency are minimised. As a result, at a power supply of 5V and at a temperature of 25°C degrees, the fixed oscillation frequency of 32 kHz will have a tolerance within 2%.

## Operating Modes and System Clocks

Present day applications require that their microcontrollers have high performance but often still demand that they consume as little power as possible, conflicting requirements that are especially true in battery powered portable applications. The fast clocks required for high performance will by their nature increase current consumption and of course vice-versa lower speed clocks reduce current consumption. As Holtek has provided these devices with both high and low speed clock sources and the means to switch between them dynamically, the user can optimise the operation of their microcontroller to achieve the best performance/power ratio.

### System Clocks

Each device has different clock sources for both the CPU and peripheral function operation. By providing the user with a wide range of clock selections using register programming, a clock system can be configured to obtain maximum application performance.

The main system clock, can come from either a high frequency,  $f_H$ , or low frequency,  $f_{SUB}$ , source, and is selected using the CKS2~CKS0 bits in the SCC register. The high speed system clock is sourced from an HXT or HIRC oscillator, selected via configuring the FHS bit in the SCC register. The low speed system clock source can be sourced from the internal clock  $f_{SUB}$ . If  $f_{SUB}$  is selected then it can be sourced by either the LXT or LIRC oscillators, selected via configuring the FSS bit in the SCC register. The other choice, which is a divided version of the high speed system oscillator has a range of  $f_H/2\sim f_H/64$ .

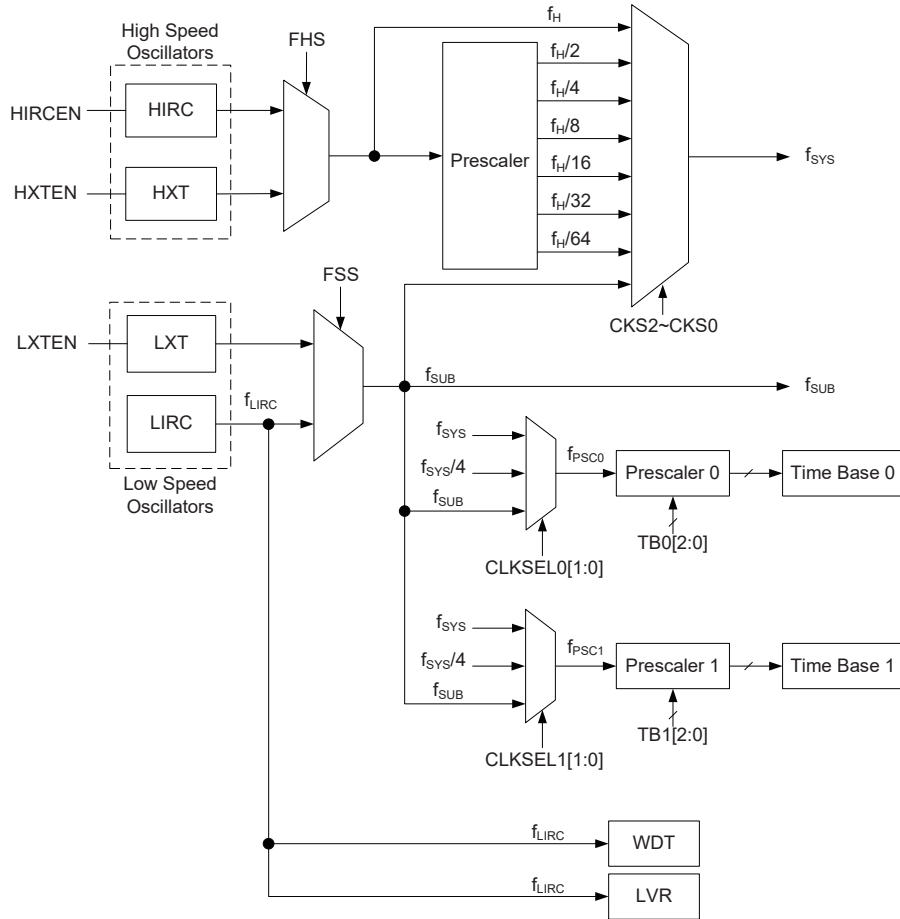

**Device Clock Configurations**

Note: When the system clock source  $f_{SYS}$  is switched to  $f_{SUB}$  from  $f_H$ , the high speed oscillation can be stopped to conserve the power or continue to oscillate to provide the clock source,  $f_H \sim f_H/64$ , for peripheral circuit to use, which is determined by configuring the corresponding high speed oscillator enable control bit.

## System Operation Modes

There are six different modes of operation for the microcontroller, each one with its own special characteristics and which can be chosen according to the specific performance and power requirements of the application. There are two modes allowing normal operation of the microcontroller, the FAST Mode and SLOW Mode. The remaining four modes, the SLEEP, IDLE0, IDLE1 and IDLE2 Mode are used when the microcontroller CPU is switched off to conserve power.

| Operation Mode | CPU | Register Setting |        |           | f <sub>sys</sub>                   | f <sub>H</sub>        | f <sub>SUB</sub> | f <sub>LIRC</sub> |
|----------------|-----|------------------|--------|-----------|------------------------------------|-----------------------|------------------|-------------------|
|                |     | FHIDEN           | FSIDEN | CKS2~CKS0 |                                    |                       |                  |                   |
| FAST           | On  | x                | x      | 000~110   | f <sub>H</sub> ~f <sub>H</sub> /64 | On                    | On               | On                |
| SLOW           | On  | x                | x      | 111       | f <sub>SUB</sub>                   | On/Off <sup>(1)</sup> | On               | On                |
| IDLE0          | Off | 0                | 1      | 000~110   | Off                                | Off                   | On               | On                |
|                |     |                  |        | 111       | On                                 |                       |                  |                   |
| IDLE1          | Off | 1                | 1      | xxx       | On                                 | On                    | On               | On                |
| IDLE2          | Off | 1                | 0      | 000~110   | On                                 | On                    | Off              | On                |
|                |     |                  |        | 111       | Off                                |                       |                  |                   |
| SLEEP          | Off | 0                | 0      | xxx       | Off                                | Off                   | Off              | On <sup>(2)</sup> |

Note: 1. The f<sub>H</sub> clock will be switched on or off by configuring the corresponding oscillator enable bit in the SLOW mode.

2. The f<sub>LIRC</sub> clock will be switched on if the WDT function is enabled.

### FAST Mode

As the name suggests this is one of the main operating modes where the microcontroller has all of its functions operational and where the system clock is provided by one of the high speed oscillators. This mode operates allowing the microcontroller to operate normally with a clock source will come from one of the high speed oscillators, either the HXT or HIRC oscillators. The high speed oscillator will however first be divided by a ratio ranging from 1 to 64, the actual ratio being selected by the CKS2~CKS0 bits in the SCC register. Although a high speed oscillator is used, running the microcontroller at a divided clock ratio reduces the operating current.

### SLOW Mode

This is also a mode where the microcontroller operates normally although now with a slower speed clock source. The clock source used will be from f<sub>SUB</sub>. The f<sub>SUB</sub> clock is derived from either the LIRC or LXT oscillator.

### SLEEP Mode

The SLEEP Mode is entered when a HALT instruction is executed and when the FHIDEN and FSIDEN bit are low. In the SLEEP mode the CPU will be stopped and both the high and low speed oscillators will be switched off. However the f<sub>LIRC</sub> clock will continue to operate if the WDT function is enabled by the WDTC register.

### IDLE0 Mode

The IDLE0 Mode is entered when a HALT instruction is executed and when the FHIDEN bit in the SCC register is low and the FSIDEN bit in the SCC register is high. In the IDLE0 Mode the CPU will be switched off but the low speed oscillator will be turned on to drive some peripheral functions.

### IDLE1 Mode

The IDLE1 Mode is entered when a HALT instruction is executed and when the FHIDEN bit in the SCC register is high and the FSIDEN bit in the SCC register is high. In the IDLE1 Mode the CPU will be switched off but both the high and low speed oscillators will be turned on to provide a clock source to keep some peripheral functions operational.

### IDLE2 Mode

The IDLE2 Mode is entered when a HALT instruction is executed and when the FHIDEN bit in the SCC register is high and the FSIDEN bit in the SCC register is low. In the IDLE2 Mode the CPU and low speed oscillator will be switched off but the high speed oscillator will be turned on to provide a clock source to keep some peripheral functions operational.

### Control Registers

The registers, SCC, HIRCC, HXTC and LXTC, are used to control the system clock and the corresponding oscillator configurations.

| Register Name | Bit  |      |      |   |       |       |        |        |
|---------------|------|------|------|---|-------|-------|--------|--------|
|               | 7    | 6    | 5    | 4 | 3     | 2     | 1      | 0      |
| SCC           | CKS2 | CKS1 | CKS0 | — | FHS   | FSS   | FHIDEN | FSIDEN |
| HIRCC         | —    | —    | —    | — | HIRC1 | HIRC0 | HIRCF  | HIRCEN |
| HXTC          | —    | —    | —    | — | —     | HXTM  | HXTF   | HXTEN  |
| LXTC          | —    | —    | —    | — | —     | —     | LXTF   | LXTEN  |

**System Operating Mode Control Registers List**

#### • SCC Register

| Bit  | 7    | 6    | 5    | 4 | 3   | 2   | 1      | 0      |
|------|------|------|------|---|-----|-----|--------|--------|
| Name | CKS2 | CKS1 | CKS0 | — | FHS | FSS | FHIDEN | FSIDEN |
| R/W  | R/W  | R/W  | R/W  | — | R/W | R/W | R/W    | R/W    |
| POR  | 0    | 0    | 0    | — | 0   | 0   | 0      | 0      |

Bit 7~5 **CKS2~CKS0**: System clock selection

000:  $f_H$   
 001:  $f_H/2$   
 010:  $f_H/4$   
 011:  $f_H/8$   
 100:  $f_H/16$   
 101:  $f_H/32$   
 110:  $f_H/64$   
 111:  $f_{SUB}$

These three bits are used to select which clock is used as the system clock source. In addition to the system clock source directly derived from  $f_H$  or  $f_{SUB}$ , a divided version of the high speed system oscillator can also be chosen as the system clock source.

Bit 4 Unimplemented, read as "0"

Bit 3 **FHS**: High Frequency clock selection

0: HIRC  
 1: HXT

Bit 2 **FSS**: Low Frequency clock selection

0: LIRC  
 1: LXT

Bit 1 **FHIDEN**: High Frequency oscillator control when CPU is switched off

0: Disable  
 1: Enable

This bit is used to control whether the high speed oscillator is activated or stopped when the CPU is switched off by executing a "HALT" instruction.

Bit 0 **FSIDEN**: Low Frequency oscillator control when CPU is switched off

0: Disable  
 1: Enable

This bit is used to control whether the low speed oscillator is activated or stopped when the CPU is switched off by executing a "HALT" instruction. The LIRC oscillator is controlled by this bit together with the WDT function enable control when the LIRC is selected to be the low speed oscillator clock source or the WDT function is enabled respectively. If this bit is cleared to 0 but the WDT function is enabled, the LIRC oscillator will also be enabled.

• **HIRCC Register**

| Bit  | 7 | 6 | 5 | 4 | 3     | 2     | 1     | 0      |
|------|---|---|---|---|-------|-------|-------|--------|
| Name | — | — | — | — | HIRC1 | HIRC0 | HIRCF | HIRCEN |
| R/W  | — | — | — | — | R/W   | R/W   | R     | R/W    |
| POR  | — | — | — | — | 0     | 0     | 0     | 1      |

Bit 7~4 Unimplemented, read as "0"

Bit 3~2 **HIRC1~HIRC0**: HIRC frequency selection

- 00: 8 MHz
- 01: 12 MHz
- 10: 16 MHz
- 11: 8 MHz

When the HIRC oscillator is enabled or the HIRC frequency selection is changed by the application program, the clock frequency will automatically be changed after the HIRCF flag is set to 1.

Bit 1 **HIRCF**: HIRC oscillator stable flag

- 0: HIRC unstable
- 1: HIRC stable

This bit is used to indicate whether the HIRC oscillator is stable or not. When the HIRCEN bit is set to 1 to enable the HIRC oscillator or the HIRC frequency selection is changed by the application program, the HIRCF bit will first be cleared to 0 and then set to 1 after the HIRC oscillator is stable.

Bit 0 **HIRCEN**: HIRC oscillator enable control

- 0: Disable
- 1: Enable

• **HXTC Register**

| Bit  | 7 | 6 | 5 | 4 | 3 | 2    | 1    | 0     |
|------|---|---|---|---|---|------|------|-------|
| Name | — | — | — | — | — | HXTM | HXTF | HXTEN |
| R/W  | — | — | — | — | — | R/W  | R    | R/W   |
| POR  | — | — | — | — | — | 0    | 0    | 0     |

Bit 7~3 Unimplemented, read as "0"

Bit 2 **HXTM**: HXT mode selection

- 0: HXT frequency  $\leq$  10 MHz
- 1: HXT frequency  $>$ 10 MHz

This bit is used to select the HXT oscillator operating mode. Note that this bit must be properly configured before the HXT is enabled. When the OSC1 and OSC2 pins are enabled and the HXTEN bit is set to 1 to enable the HXT oscillator, it is invalid to change the value of this bit. Otherwise, this bit value can be changed with no operation on the HXT function.

Bit 1 **HXTF**: HXT oscillator stable flag

- 0: HXT unstable
- 1: HXT stable

This bit is used to indicate whether the HXT oscillator is stable or not. When the HXTEN bit is set to 1 to enable the HXT oscillator, the HXTF bit will first be cleared to 0 and then set to 1 after the HXT oscillator is stable.

Bit 0 **HXTEN**: HXT oscillator enable control

- 0: Disable
- 1: Enable

• **LXTC Register**

| Bit  | 7 | 6 | 5 | 4 | 3 | 2 | 1    | 0     |
|------|---|---|---|---|---|---|------|-------|
| Name | — | — | — | — | — | — | LXTF | LXTEN |
| R/W  | — | — | — | — | — | — | R    | R/W   |
| POR  | — | — | — | — | — | — | 0    | 0     |

Bit 7~2 Unimplemented, read as "0"

Bit 1 **LXTF**: LXT oscillator stable flag  
 0: LXT unstable  
 1: LXT stable

This bit is used to indicate whether the LXT oscillator is stable or not. When the LXTEN bit is set to 1 to enable the LXT oscillator, the LXTF bit will first be cleared to 0 and then set to 1 after the LXT oscillator is stable.

Bit 0 **LXTEN**: LXT oscillator enable control  
 0: Disable  
 1: Enable

**Operating Mode Switching**

These devices can switch between operating modes dynamically allowing the user to select the best performance/power ratio for the present task in hand. In this way microcontroller operations that do not require high performance can be executed using slower clocks thus requiring less operating current and prolonging battery life in portable applications.

In simple terms, Mode Switching between the FAST Mode and SLOW Mode is executed using the CKS2~CKS0 bits in the SCC register while Mode Switching from the FAST/SLOW Modes to the SLEEP/IDLE Modes is executed via the HALT instruction. When a HALT instruction is executed, whether the device enters the IDLE Mode or the SLEEP Mode is determined by the condition of the FHIDEN and FSIDEN bits in the SCC register.

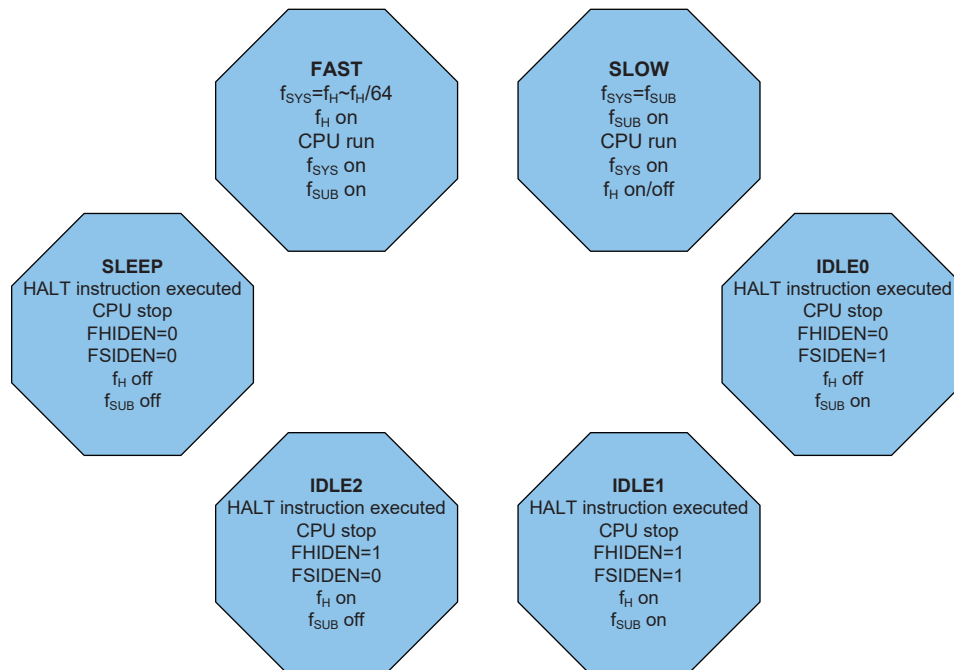

### FAST Mode to SLOW Mode Switching

When running in the FAST Mode, which uses the high speed system oscillator, and therefore consumes more power, the system clock can switch to run in the SLOW Mode by set the CKS2~CKS0 bits to "111" in the SCC register. This will then use the low speed system oscillator which will consume less power. Users may decide to do this for certain operations which do not require high performance and can subsequently reduce power consumption.

The SLOW Mode is sourced from the LXT or LIRC oscillator determined by the FSS bit in the SCC register and therefore requires this oscillator to be stable before full mode switching occurs.

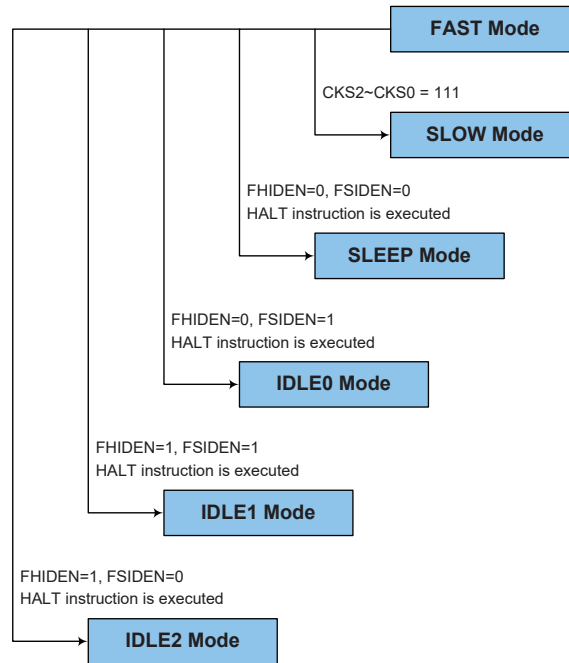

### SLOW Mode to FAST Mode Switching

In SLOW mode the system clock is derived from  $f_{SUB}$ . When system clock is switched back to the FAST mode from  $f_{SUB}$ , the CKS2 ~ CKS0 bits should be set to "000" ~ "110" and then the system clock will respectively be switched to  $f_H \sim f_H/64$ .

However, if  $f_H$  is not used in SLOW mode and thus switched off, it will take some time to re-oscillate and stabilise when switching to the FAST mode from the SLOW Mode. This is monitored using the HXTF bit in the HXTC register or the HIRCF bit in the HIRCC register. The time duration required for the high speed system oscillator stabilization is specified in the relevant characteristics.

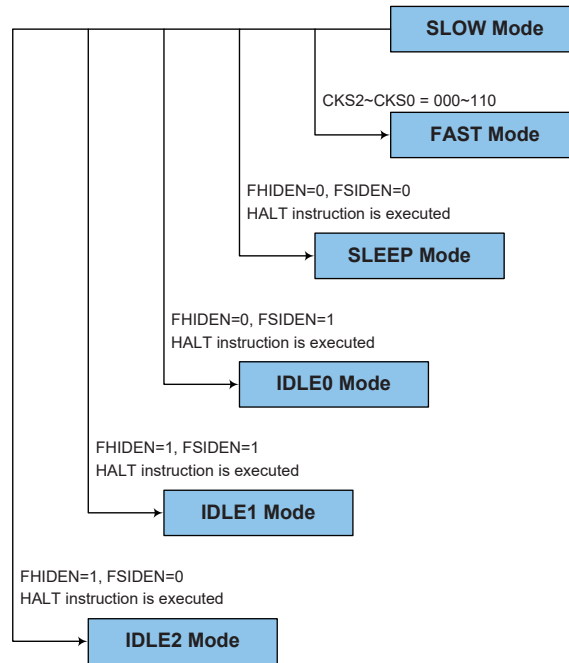

### Entering the SLEEP Mode

There is only one way for the device to enter the SLEEP Mode and that is to execute the "HALT" instruction in the application program with both the FHIDEN and FSIDEN bits in the SCC register equal to "0". In this mode all the clocks and functions will be switched off except the WDT function. When this instruction is executed under the conditions described above, the following will occur:

- The system clock will be stopped and the application program will stop at the "HALT" instruction.
- The Data Memory contents and registers will maintain their present condition.
- The I/O ports will maintain their present conditions.
- In the status register, the Power Down flag PDF will be set, and WDT timeout flag TO will be cleared.
- The WDT will be cleared and resume counting if the WDT function is enabled by the WDTC register.

### Entering the IDLE0 Mode

There is only one way for the device to enter the IDLE0 Mode and that is to execute the "HALT" instruction in the application program with the FHIDEN bit in the SCC register equal to "0" and the FSIDEN bit in the SCC register equal to "1". When this instruction is executed under the conditions described above, the following will occur:

- The  $f_H$  clock will be stopped and the application program will stop at the "HALT" instruction, but the  $f_{SUB}$  clock will be on.
- The Data Memory contents and registers will maintain their present condition.
- The I/O ports will maintain their present conditions.
- In the status register, the Power Down flag PDF will be set, and WDT timeout flag TO will be cleared.
- The WDT will be cleared and resume counting if the WDT function is enabled by the WDTC register.

### Entering the IDLE1 Mode

There is only one way for the device to enter the IDLE1 Mode and that is to execute the "HALT" instruction in the application program with both the FHIDEN and FSIDEN bits in the SCC register equal to "1". When this instruction is executed under the conditions described above, the following will occur:

- The  $f_H$  and  $f_{SUB}$  clocks will be on but the application program will stop at the "HALT" instruction.
- The Data Memory contents and registers will maintain their present condition.
- The I/O ports will maintain their present conditions.
- In the status register, the Power Down flag PDF will be set, and WDT timeout flag TO will be cleared.
- The WDT will be cleared and resume counting if the WDT function is enabled by the WDTC register.

### Entering the IDLE2 Mode

There is only one way for the device to enter the IDLE2 Mode and that is to execute the "HALT" instruction in the application program with the FHIDEN bit in the SCC register equal to "1" and the FSIDEN bit in the SCC register equal to "0". When this instruction is executed under the conditions described above, the following will occur:

- The  $f_H$  clock will be on but the  $f_{SUB}$  clock will be off and the application program will stop at the "HALT" instruction.
- The Data Memory contents and registers will maintain their present condition.
- The I/O ports will maintain their present conditions.
- In the status register, the Power Down flag PDF will be set, and WDT timeout flag TO will be cleared.
- The WDT will be cleared and resume counting if the WDT function is enabled by the WDTC register.

## Standby Current Considerations

As the main reason for entering the SLEEP or IDLE Mode is to keep the current consumption of the device to as low a value as possible, perhaps only in the order of several micro-amps except in the IDLE1 and IDLE2 Mode, there are other considerations which must also be taken into account by the circuit designer if the power consumption is to be minimised. Special attention must be made to the I/O pins on the device. All high-impedance input pins must be connected to either a fixed high or low level as any floating input pins could create internal oscillations and result in increased current consumption. This also applies to devices which have different package types, as there may be unbonded pins. These must either be setup as outputs or if setup as inputs must have pull-high resistors connected.

Care must also be taken with the loads, which are connected to I/O pins, which are setup as outputs. These should be placed in a condition in which minimum current is drawn or connected only to external circuits that do not draw current, such as other CMOS inputs. Also note that additional standby current will also be required if the LIRC oscillator has enabled.

In the IDLE1 and IDLE 2 Mode the high speed oscillator is on, if the peripheral function clock source is derived from the high speed oscillator, the additional standby current will also be perhaps in the order of several hundred micro-amps.

## Wake-up

To minimise power consumption the device can enter the SLEEP or any IDLE Mode, where the CPU will be switched off. However, when the device is woken up again, it will take a considerable time for the original system oscillator to restart, stabilise and allow normal operation to resume.

After the system enters the SLEEP or IDLE Mode, it can be woken up from one of various sources listed as follows:

- An external falling edge on Port A
- An external reset
- A system interrupt
- A WDT overflow

When the device executes the "HALT" instruction, the PDF flag will be set to 1. The PDF flag will be cleared to 0 if the device experiences a system power-up or executes the clear Watchdog Timer instruction. If the system is woken up by a WDT overflow, a Watchdog Timer reset will be initiated and the TO flag will be set to 1. The TO flag is set if a WDT time-out occurs and causes a wake-up that only resets the Program Counter and Stack Pointer, other flags remain in their original status.

Each pin on Port A can be setup using the PAWU register to permit a negative transition on the pin to wake up the system. When a Port A pin wake-up occurs, the program will resume execution at the instruction following the "HALT" instruction. If the system is woken up by an interrupt, then two possible situations may occur. The first is where the related interrupt is disabled or the interrupt is enabled but the stack is full, in which case the program will resume execution at the instruction following the "HALT" instruction. In this situation, the interrupt which woke up the device will not be immediately serviced, but will rather be serviced later when the related interrupt is finally enabled or when a stack level becomes free. The other situation is where the related interrupt is enabled and the stack is not full, in which case the regular interrupt response takes place. If an interrupt request flag is set high before entering the SLEEP or IDLE Mode, the wake-up function of the related interrupt will be disabled.

## Watchdog Timer

The Watchdog Timer is provided to prevent program malfunctions or sequences from jumping to unknown locations, due to certain uncontrollable external events such as electrical noise.

### Watchdog Timer Clock Source

The Watchdog Timer clock source is provided by the internal RC oscillator,  $f_{LIRC}$ . The LIRC internal oscillator has an approximate frequency of 32 kHz and this specified internal clock period can vary with  $V_{DD}$ , temperature and process variations. The Watchdog Timer source clock is then subdivided by a ratio of  $2^8$  to  $2^{18}$  to give longer timeouts, the actual value being chosen using the WS2~WS0 bits in the WDTC register.

### Watchdog Timer Control Register

A single register, WDTC, controls the required timeout period as well as the enable/disable operation. This register controls the overall operation of the Watchdog Timer.

#### • WDTC Register

| Bit  | 7   | 6   | 5   | 4   | 3   | 2   | 1   | 0   |
|------|-----|-----|-----|-----|-----|-----|-----|-----|
| Name | WE4 | WE3 | WE2 | WE1 | WE0 | WS2 | WS1 | WS0 |
| R/W  | R/W | R/W | R/W | R/W | R/W | R/W | R/W | R/W |
| POR  | 0   | 1   | 0   | 1   | 0   | 0   | 1   | 1   |

Bit 7~3 **WE4~WE0**: WDT function enable control

10101: Disabled

01010: Enabled

Other values: Reset MCU

If these bits are changed due to adverse environmental conditions, the microcontroller will be reset. The reset operation will be activated after a delay time,  $t_{SRESET}$ , and the WRF bit in the RSTFC register will be set to 1.

Bit 2~0 **WS2~WS0**: WDT time-out period selection

000:  $2^8/f_{LIRC}$

001:  $2^{10}/f_{LIRC}$

010:  $2^{12}/f_{LIRC}$

011:  $2^{14}/f_{LIRC}$

100:  $2^{15}/f_{LIRC}$

101:  $2^{16}/f_{LIRC}$

110:  $2^{17}/f_{LIRC}$

111:  $2^{18}/f_{LIRC}$

These three bits determine the division ratio of the watchdog timer source clock, which in turn determines the time-out period.

#### • RSTFC Register

| Bit  | 7 | 6 | 5 | 4 | 3    | 2    | 1   | 0   |
|------|---|---|---|---|------|------|-----|-----|
| Name | — | — | — | — | RSTF | LVRF | LRF | WRF |
| R/W  | — | — | — | — | R/W  | R/W  | R/W | R/W |
| POR  | — | — | — | — | 0    | x    | 0   | 0   |

"x": unknown

Bit 7~4 Unimplemented, read as "0"

Bit 3 **RSTF**: Reset control register software reset flag

Described elsewhere.

Bit 2 **LVRF**: LVR function reset flag

Described elsewhere.

- Bit 1      **LRF:** LVR control register software reset flag  
                  Described elsewhere.
- Bit 0      **WRF:** WDT control register software reset flag  
                  0: Not occurred  
                  1: Occurred  
                  This bit is set to 1 by the WDT control register software reset and cleared by the application program. Note that this bit can only be cleared to 0 by the application program.

### Watchdog Timer Operation

The Watchdog Timer operates by providing a device reset when its timer overflows. This means that in the application program and during normal operation the user has to strategically clear the Watchdog Timer before it overflows to prevent the Watchdog Timer from executing a reset. This is done using the clear watchdog instruction. If the program malfunctions for whatever reason, jumps to an unknown location, or enters an endless loop, the clear instruction will not be executed in the correct manner, in which case the Watchdog Timer will overflow and reset the device. With regard to the Watchdog Timer enable/disable function, there are five bits, WE4~WE0, in the WDTC register to offer the enable/disable control and reset control of the Watchdog Timer. The WDT function will be enabled when the WE4~WE0 bits are set to a value of 01010B while the WDT function will be disabled if the WE4~WE0 bits are equal to 10101B. If the WE4~WE0 bits are set to any other values rather than 01010B and 10101B, it will reset the device after a delay time,  $t_{SRESET}$ . After power on these bits will have a value of 01010B.

| WE4 ~ WE0 Bits  | WDT Function |
|-----------------|--------------|
| 10101B          | Disable      |
| 01010B          | Enable       |
| Any other value | Reset MCU    |

#### Watchdog Timer Enable/Disable Control

Under normal program operation, a Watchdog Timer time-out will initialise a device reset and set the status bit TO. However, if the system is in the SLEEP or IDLE Mode, when a Watchdog Timer time-out occurs, the TO bit in the status register will be set and only the Program Counter and Stack Pointer will be reset. Four methods can be adopted to clear the contents of the Watchdog Timer. The first is a WDT reset, which means a certain value except 01010B and 10101B written into the WE4~WE0 field, the second is using the Watchdog Timer software clear instruction and the third is via a HALT instruction. The last is an external hardware reset, which means a low level on the external reset pin if the external reset pin exists by the RSTC register.

There is only one method of using software instruction to clear the Watchdog Timer. That is to use the single "CLR WDT" instruction to clear the WDT contents.

The maximum time out period is when the  $2^{18}$  division ratio is selected. As an example, with a 32 kHz LIRC oscillator as its source clock, this will give a maximum watchdog period of around 8 second for the  $2^{18}$  division ratio and a minimum timeout of 8ms for the  $2^8$  division ratio.

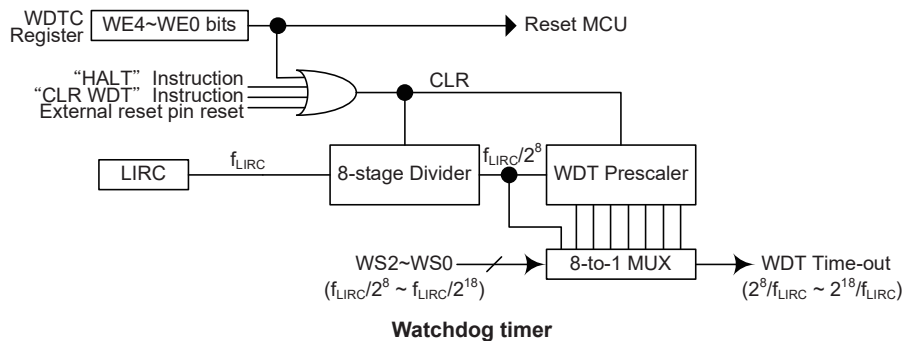

## Reset and Initialisation

A reset function is a fundamental part of any microcontroller ensuring that the device can be set to some predetermined condition irrespective of outside parameters. The most important reset condition is after power is first applied to the microcontroller. In this case, internal circuitry will ensure that the microcontroller, after a short delay, will be in a well defined state and ready to execute the first program instruction. After this power-on reset, certain important internal registers will be set to defined states before the program commences. One of these registers is the Program Counter, which will be reset to zero forcing the microcontroller to begin program execution from the lowest Program Memory address.

In addition to the power-on reset, situations may arise where it is necessary to forcefully apply a reset condition when the microcontroller is already running, the  $\overline{\text{RES}}$  line is forcefully pulled low. In such a case, known as a normal operation reset, some of the microcontroller registers remain unchanged allowing the microcontroller to proceed with normal operation after the reset line is allowed to return high.

The Watchdog Timer overflow is one of many reset types and will reset the microcontroller. Another reset exists in the form of a Low Voltage Reset, LVR, where a full reset, similar to the  $\overline{\text{RES}}$  reset is implemented in situations where the power supply voltage falls below a certain threshold. Another type of reset is when the Watchdog Timer overflows and resets the microcontroller. All types of reset operations result in different register conditions being setup.

### Reset Functions

There are five ways in which a microcontroller reset can occur, through events occurring both internally and externally.

#### Power-on Reset

The most fundamental and unavoidable reset is the one that occurs after power is first applied to the microcontroller. As well as ensuring that the Program Memory begins execution from the first memory address, a power-on reset also ensures that certain other registers are preset to known conditions. All the I/O port and port control registers will power up in a high condition ensuring that all pins will be first set to inputs.

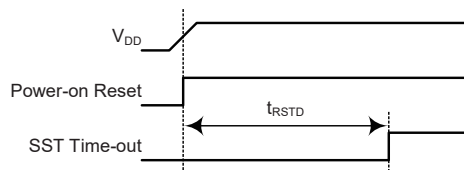

Note:  $t_{RSTD}$  is power-on delay with typical time=48 ms

**Power-On Reset Timing Chart**

### RES Pin Reset

As the reset pin is shared with I/O pins, the reset function must be selected using a control register, RSTC. Although the microcontroller has an internal RC reset function, if the VDD power supply rise time is not fast enough or does not stabilise quickly at power-on, the internal reset function may be incapable of providing proper reset operation. For this reason it is recommended that an external RC network is connected to the  $\overline{\text{RES}}$  pin, whose additional time delay will ensure that the  $\overline{\text{RES}}$  pin remains low for an extended period to allow the power supply to stabilise. During this time delay, normal operation of the microcontroller will be inhibited. After the  $\overline{\text{RES}}$  line reaches a certain voltage value, the reset delay time,  $t_{\text{RSTD}}$ , is invoked to provide an extra delay time after which the microcontroller will begin normal operation. The abbreviation SST in the figures stands for System Start-up Time. For most applications a resistor connected between VDD and the RES line and a capacitor connected between VSS and the RES pin will provide a suitable external reset circuit. Any wiring connected to the  $\overline{\text{RES}}$  pin should be kept as short as possible to minimise any stray noise interference. For applications that operate within an environment where more noise is present the Enhanced Reset Circuit shown is recommended.

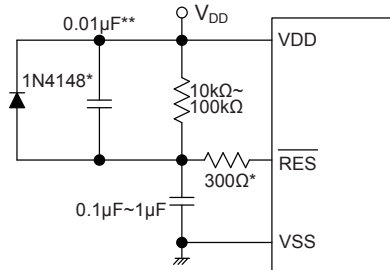

Note: "\*" It is recommended that this component is added for added ESD protection.

"\*\*" It is recommended that this component is added in environments where power line noise is significant.

### External $\overline{\text{RES}}$ Circuit

Pulling the  $\overline{\text{RES}}$  pin low using external hardware will also execute a device reset. In this case, as in the case of other resets, the Program Counter will reset to zero and program execution initiated from this point.

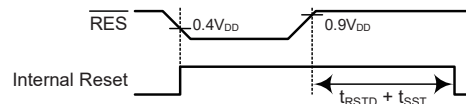

Note:  $t_{\text{RSTD}}$  is power-on delay with typical time=16 ms

### RES Reset Timing Chart

There is an internal reset control register, RSTC, which is used to select the external  $\overline{\text{RES}}$  pin function and provide a reset when the device operates abnormally due to the environmental noise interference. If the content of the RSTC register is set to any value other than 01010101B or 10101010B, it will reset the device after a delay time,  $t_{\text{RRESET}}$ . After power on the register will have a value of 01010101B.

| RSTC7 ~ RSTC0 Bits | Reset Function          |
|--------------------|-------------------------|
| 01010101B          | I/O                     |
| 10101010B          | $\overline{\text{RES}}$ |
| Any other value    | Reset MCU               |

### Internal Reset Function Control

• **RSTC Register**

| Bit  | 7     | 6     | 5     | 4     | 3     | 2     | 1     | 0     |
|------|-------|-------|-------|-------|-------|-------|-------|-------|
| Name | RSTC7 | RSTC6 | RSTC5 | RSTC4 | RSTC3 | RSTC2 | RSTC1 | RSTC0 |
| R/W  | R/W   | R/W   | R/W   | R/W   | R/W   | R/W   | R/W   | R/W   |
| POR  | 0     | 1     | 0     | 1     | 0     | 1     | 0     | 1     |

Bit 7~0 **RSTC7~RSTC0**: Reset function control  
 01010101: I/O pin  
 10101010:  $\overline{\text{RES}}$  pin  
 Other values: Reset MCU  
 If these bits are changed due to adverse environmental conditions, the microcontroller will be reset. The reset operation will be activated after a delay time,  $t_{\text{SRESET}}$ , and the RSTF bit in the RSTFC register will be set to 1.  
 All resets will reset this register to POR value except the WDT time out hardware warm reset. Note that if the register is set to 10101010 to select the  $\overline{\text{RES}}$  pin, this configuration has higher priority than other related pin-shared controls.

• **RSTFC Register**

| Bit  | 7 | 6 | 5 | 4 | 3    | 2    | 1   | 0   |
|------|---|---|---|---|------|------|-----|-----|
| Name | — | — | — | — | RSTF | LVRF | LRF | WRF |
| R/W  | — | — | — | — | R/W  | R/W  | R/W | R/W |
| POR  | — | — | — | — | 0    | x    | 0   | 0   |

"x": unknown

Bit 7~4 Unimplemented, read as "0"  
 Bit 3 **RSTF**: Reset control register software reset flag  
 0: Not occurred  
 1: Occurred  
 This bit is set to 1 by the RSTC control register software reset and cleared by the application program. Note that this bit can only be cleared to 0 by the application program.  
 Bit 2 **LVRF**: LVR function reset flag  
 Described elsewhere.  
 Bit 1 **LRF**: LVR control register software reset flag  
 Described elsewhere.  
 Bit 0 **WRF**: WDT control register software reset flag  
 Described elsewhere.

**Low Voltage Reset – LVR**

The microcontroller contains a low voltage reset circuit in order to monitor the supply voltage of the device. The LVR function is always enabled with a specific LVR voltage,  $V_{\text{LVR}}$ . If the supply voltage of the device drops to within a range of  $0.9V \sim V_{\text{LVR}}$  such as might occur when changing the battery, the LVR will automatically reset the device internally and the LVRF bit in the RSTFC register will also be set to 1. For a valid LVR signal, a low supply voltage, i.e., a voltage in the range between  $0.9V \sim V_{\text{LVR}}$  must exist for a time greater than that specified by  $t_{\text{LVR}}$  in the LVD/LVR Electrical Characteristics. If the low supply voltage state does not exceed this value, the LVR will ignore the low supply voltage and will not perform a reset function. The actual  $V_{\text{LVR}}$  value can be selected by the LVS bits in the LVRC register. If the LVS7~LVS0 bits have any other value, which may perhaps occur due to adverse environmental conditions such as noise, the LVR will reset the device after a delay time,  $t_{\text{SRESET}}$ . When this happens, the LRF bit in the RSTFC register will be set to 1. After power on the register will have the value of 01010101B. Note that the LVR function will be automatically disabled when the device enters the power down mode.

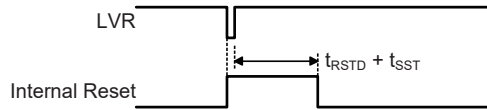

Note:  $t_{RSTD}$  is power-on delay with typical time=48ms

**Low Voltage Reset Timing Chart**

• **LVRC Register**

| Bit  | 7    | 6    | 5    | 4    | 3    | 2    | 1    | 0    |
|------|------|------|------|------|------|------|------|------|
| Name | LVS7 | LVS6 | LVS5 | LVS4 | LVS3 | LVS2 | LVS1 | LVS0 |
| R/W  | R/W  | R/W  | R/W  | R/W  | R/W  | R/W  | R/W  | R/W  |
| POR  | 0    | 1    | 0    | 1    | 0    | 1    | 0    | 1    |

Bit 7~0 **LVS7~LVS0:** LVR voltage select

01010101: 2.1V  
00110011: 2.55V  
10011001: 3.15V  
10101010: 3.8V

Other values: Generates a MCU reset – register is reset to POR value

When an actual low voltage condition occurs, as specified by one of the four defined LVR voltage value above, an MCU reset will generated. The reset operation will be activated after the low voltage condition keeps more than a  $t_{LVR}$  time. In this situation the register contents will remain the same after such a reset occurs.

Any register value, other than the four defined register values above, will also result in the generation of an MCU reset. The reset operation will be activated after a delay time,  $t_{SRESET}$ . However in this situation the register contents will be reset to the POR value.

• **RSTFC Register**

| Bit  | 7 | 6 | 5 | 4 | 3    | 2    | 1   | 0   |
|------|---|---|---|---|------|------|-----|-----|
| Name | — | — | — | — | RSTF | LVRF | LRF | WRF |
| R/W  | — | — | — | — | R/W  | R/W  | R/W | R/W |
| POR  | — | — | — | — | 0    | x    | 0   | 0   |

"x": unknown

Bit 7~4 Unimplemented, read as "0"

Bit 3 **RSTF:** Reset control register software reset flag  
Described elsewhere.

Bit 2 **LVRF:** LVR function reset flag  
0: Not occurred  
1: Occurred

This bit is set to 1 when a specific low voltage reset condition occurs. Note that this bit can only be cleared to 0 by the application program.

Bit 1 **LRF:** LVR control register software reset flag  
0: Not occurred  
1: Occurred

This bit is set to 1 by the LVRC control register contains any undefined LVR voltage register values. This in effect acts like a software-reset function. Note that this bit can only be cleared to 0 by the application program.

Bit 0 **WRF:** WDT control register software reset flag  
Described elsewhere.

### Watchdog Time-out Reset during Normal Operation

The Watchdog time-out Reset during normal operation is the same as the hardware Low Voltage Reset except that the Watchdog time-out flag TO will be set to "1".

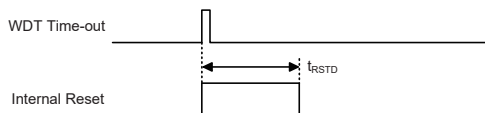

Note:  $t_{RSTD}$  is power-on delay with typical time=16 ms

**WDT Time-out Reset during NORMAL Operation Timing Chart**

### Watchdog Time-out Reset during SLEEP or IDLE Mode

The Watchdog time-out Reset during SLEEP or IDLE Mode is a little different from other kinds of reset. Most of the conditions remain unchanged except that the Program Counter and the Stack Pointer will be cleared to "0" and the TO flag will be set to "1". Refer to the A.C. Characteristics for  $t_{SST}$  details.

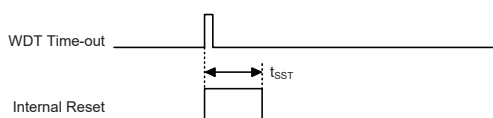

**WDT Time-out Reset during SLEEP or IDLE Mode Timing Chart**

### Reset Initial Conditions

The different types of reset described affect the reset flags in different ways. These flags, known as PDF and TO are located in the status register and are controlled by various microcontroller operations, such as the SLEEP or IDLE Mode function or Watchdog Timer. The reset flags are shown in the table:

| TO | PDF | Reset Function   |
|----|-----|--|
| 0  | 0   | Power-on reset   |
| u  | u   | RES or LVR reset during FAST or SLOW Mode operation    |
| 1  | u   | WDT time-out reset during FAST or SLOW Mode operation  |
| 1  | 1   | WDT time-out reset during IDLE or SLEEP Mode operation |

Note "u" stands for unchanged

The following table indicates the way in which the various components of the microcontroller are affected after a power-on reset occurs.

| Item               | Reset Function                                   |
|--------------------|--|
| Program Counter    | Reset to zero                                    |
| Interrupts         | All interrupts will be disabled                  |
| WDT, Time Base     | Clear after reset, WDT begins counting           |
| Timer Modules      | Timer Modules will be turned off                 |
| Input/Output Ports | I/O ports will be setup as inputs                |
| Stack pointer      | Stack pointer will point to the top of the stack |

The different kinds of resets all affect the internal registers of the microcontroller in different ways. To ensure reliable continuation of normal program execution after a reset occurs, it is important to know what condition the microcontroller is in after a particular reset occurs. The following table describes how each type of reset affects the microcontroller internal registers.

| Register | HT66F2350 | HT66F2360 | HT66F2370 | HT66F2390 | Reset (Power On) | RES Reset (Normal Operation) | LVR Reset (Normal Operation) | WDT Time-out (Normal Operation) | WDT Time-out (IDLE/SLEEP) |
|----------|-----------|-----------|-----------|-----------|------------------|------------------------------|------------------------------|---------------------------------|---------------------------|
| IAR0     | •         | •         | •         | •         | 0000 0000        | 0000 0000                    | 0000 0000                    | 0000 0000                       | uuuu uuuu                 |
| MP0      | •         | •         | •         | •         | 0000 0000        | 0000 0000                    | 0000 0000                    | 0000 0000                       | uuuu uuuu                 |
| IAR1     | •         | •         | •         | •         | 0000 0000        | 0000 0000                    | 0000 0000                    | 0000 0000                       | uuuu uuuu                 |
| MP1L     | •         | •         | •         | •         | 0000 0000        | 0000 0000                    | 0000 0000                    | 0000 0000                       | uuuu uuuu                 |
| MP1H     | •         | •         | •         | •         | 0000 0000        | 0000 0000                    | 0000 0000                    | 0000 0000                       | uuuu uuuu                 |
| ACC      | •         | •         | •         | •         | xxxx xxxx        | uuuu uuuu                    | uuuu uuuu                    | uuuu uuuu                       | uuuu uuuu                 |
| PCL      | •         | •         | •         | •         | 0000 0000        | 0000 0000                    | 0000 0000                    | 0000 0000                       | 0000 0000                 |
| TBLP     | •         | •         | •         | •         | xxxx xxxx        | uuuu uuuu                    | uuuu uuuu                    | uuuu uuuu                       | uuuu uuuu                 |
| TBLH     | •         | •         | •         | •         | xxxx xxxx        | uuuu uuuu                    | uuuu uuuu                    | uuuu uuuu                       | uuuu uuuu                 |
| TBHP     | •         |           |           |           | ---x xxxx        | ---u uuuu                    | ---u uuuu                    | ---u uuuu                       | ---u uuuu                 |
| TBHP     |           | •         |           |           | --xx xxxx        | --uu uuuu                    | --uu uuuu                    | --uu uuuu                       | --uu uuuu                 |
| TBHP     |           |           | •         |           | -xxx xxxx        | -uuu uuuu                    | -uuu uuuu                    | -uuu uuuu                       | -uuu uuuu                 |
| TBHP     |           |           |           | •         | xxxx xxxx        | uuuu uuuu                    | uuuu uuuu                    | uuuu uuuu                       | uuuu uuuu                 |
| STATUS   | •         | •         | •         | •         | xx00 xxxx        | uuuu uuuu                    | uuuu uuuu                    | xx1u uuuu                       | uu11 uuuu                 |
| PBP      |           | •         |           |           | ---- --0         | ---- --0                     | ---- --0                     | ---- --0                        | ---- --u                  |
| PBP      |           |           | •         |           | ---- --00        | ---- --00                    | ---- --00                    | ---- --00                       | ---- --uu                 |
| PBP      |           |           |           | •         | ---- -000        | ---- -000                    | ---- -000                    | ---- -000                       | ---- -uuu                 |
| IAR2     | •         | •         | •         | •         | xxxx xxxx        | uuuu uuuu                    | uuuu uuuu                    | uuuu uuuu                       | uuuu uuuu                 |
| MP2L     | •         | •         | •         | •         | 0000 0000        | 0000 0000                    | 0000 0000                    | 0000 0000                       | uuuu uuuu                 |
| MP2H     | •         | •         | •         | •         | 0000 0000        | 0000 0000                    | 0000 0000                    | 0000 0000                       | uuuu uuuu                 |
| RSTFC    | •         | •         | •         | •         | ---- 0x00        | ---- uuuu                    | ---- u1uu                    | ---- uuuu                       | ---- uuuu                 |
| INTC0    | •         | •         | •         | •         | -000 0000        | -000 0000                    | -000 0000                    | -000 0000                       | -uuu uuuu                 |
| INTC1    | •         | •         | •         | •         | 0000 0000        | 0000 0000                    | 0000 0000                    | 0000 0000                       | uuuu uuuu                 |
| INTC2    | •         | •         | •         | •         | 0000 0000        | 0000 0000                    | 0000 0000                    | 0000 0000                       | uuuu uuuu                 |
| INTC3    | •         | •         | •         | •         | 0000 0000        | 0000 0000                    | 0000 0000                    | 0000 0000                       | uuuu uuuu                 |
| PA       | •         | •         | •         | •         | 1111 1111        | 1111 1111                    | 1111 1111                    | 1111 1111                       | uuuu uuuu                 |
| PAC      | •         | •         | •         | •         | 1111 1111        | 1111 1111                    | 1111 1111                    | 1111 1111                       | uuuu uuuu                 |
| PAPU     | •         | •         | •         | •         | 0000 0000        | 0000 0000                    | 0000 0000                    | 0000 0000                       | uuuu uuuu                 |
| PAWU     | •         | •         | •         | •         | 0000 0000        | 0000 0000                    | 0000 0000                    | 0000 0000                       | uuuu uuuu                 |
| PB       | •         | •         | •         | •         | 1111 1111        | 1111 1111                    | 1111 1111                    | 1111 1111                       | uuuu uuuu                 |
| PBC      | •         | •         | •         | •         | 1111 1111        | 1111 1111                    | 1111 1111                    | 1111 1111                       | uuuu uuuu                 |
| PBPU     | •         | •         | •         | •         | 0000 0000        | 0000 0000                    | 0000 0000                    | 0000 0000                       | uuuu uuuu                 |
| PC       | •         | •         | •         | •         | 1111 1111        | 1111 1111                    | 1111 1111                    | 1111 1111                       | uuuu uuuu                 |
| PCC      | •         | •         | •         | •         | 1111 1111        | 1111 1111                    | 1111 1111                    | 1111 1111                       | uuuu uuuu                 |
| PCPU     | •         | •         | •         | •         | 0000 0000        | 0000 0000                    | 0000 0000                    | 0000 0000                       | uuuu uuuu                 |
| PD       | •         | •         | •         | •         | -111 1111        | -111 1111                    | -111 1111                    | -111 1111                       | -uuu uuuu                 |
| PDC      | •         | •         | •         | •         | -111 1111        | -111 1111                    | -111 1111                    | -111 1111                       | -uuu uuuu                 |
| PDPU     | •         | •         | •         | •         | -000 0000        | -000 0000                    | -000 0000                    | -000 0000                       | -uuu uuuu                 |
| PE       | •         | •         | •         | •         | ---1 1111        | ---1 1111                    | ---1 1111                    | ---1 1111                       | ---u uuuu                 |
| PEC      | •         | •         | •         | •         | ---1 1111        | ---1 1111                    | ---1 1111                    | ---1 1111                       | ---u uuuu                 |
| PEPU     | •         | •         | •         | •         | ---0 0000        | ---0 0000                    | ---0 0000                    | ---0 0000                       | ---u uuuu                 |
| PF       | •         | •         | •         | •         | 1111 1111        | 1111 1111                    | 1111 1111                    | 1111 1111                       | uuuu uuuu                 |
| PFC      | •         | •         | •         | •         | 1111 1111        | 1111 1111                    | 1111 1111                    | 1111 1111                       | uuuu uuuu                 |
| PFPU     | •         | •         | •         | •         | 0000 0000        | 0000 0000                    | 0000 0000                    | 0000 0000                       | uuuu uuuu                 |
| PG       |           | •         | •         | •         | 1111 1111        | 1111 1111                    | 1111 1111                    | 1111 1111                       | uuuu uuuu                 |

| Register | HT66F2350 | HT66F2360 | HT66F2370 | HT66F2390 | Reset (Power On) | RES Reset (Normal Operation) | LVR Reset (Normal Operation) | WDT Time-out (Normal Operation) | WDT Time-out (IDLE/SLEEP) |
|----------|-----------|-----------|-----------|-----------|------------------|------------------------------|------------------------------|---------------------------------|---------------------------|
| PGC      |           | •         | •         | •         | 1111 1111        | 1111 1111                    | 1111 1111                    | 1111 1111                       | uuuu uuuu                 |
| PGPU     |           | •         | •         | •         | 0000 0000        | 0000 0000                    | 0000 0000                    | 0000 0000                       | uuuu uuuu                 |
| PH       |           | •         | •         | •         | --11 1111        | --11 1111                    | --11 1111                    | --11 1111                       | --uu uuuu                 |
| PHC      |           | •         | •         | •         | --11 1111        | --11 1111                    | --11 1111                    | --11 1111                       | --uu uuuu                 |
| PHPU     |           | •         | •         | •         | --00 0000        | --00 0000                    | --00 0000                    | --00 0000                       | --uu uuuu                 |
| PMPS     | •         | •         | •         | •         | ---- --00        | ---- --00                    | ---- --00                    | ---- --00                       | ---- --uu                 |
| RSTC     | •         | •         | •         | •         | 0101 0101        | 0101 0101                    | 0101 0101                    | 0101 0101                       | uuuu uuuu                 |
| VBGRC    | •         | •         | •         | •         | ---- --0         | ---- --0                     | ---- --0                     | ---- --0                        | ---- --u                  |
| MF10     | •         | •         | •         | •         | 0000 0000        | 0000 0000                    | 0000 0000                    | 0000 0000                       | uuuu uuuu                 |
| MF11     | •         | •         | •         | •         | 0000 0000        | 0000 0000                    | 0000 0000                    | 0000 0000                       | uuuu uuuu                 |
| MF12     | •         | •         | •         | •         | --00 --00        | --00 --00                    | --00 --00                    | --00 --00                       | --uu --uu                 |
| MF13     | •         | •         | •         | •         | 0000 0000        | 0000 0000                    | 0000 0000                    | 0000 0000                       | uuuu uuuu                 |
| MF14     | •         | •         | •         | •         | 0000 0000        | 0000 0000                    | 0000 0000                    | 0000 0000                       | uuuu uuuu                 |
| MF15     | •         | •         |           |           | --00 --00        | --00 --00                    | --00 --00                    | --00 --00                       | --uu --uu                 |
| MF15     |           |           | •         | •         | -000 -000        | -000 -000                    | -000 -000                    | -000 -000                       | -uuu -uuu                 |
| INTEG    | •         | •         | •         | •         | 0000 0000        | 0000 0000                    | 0000 0000                    | 0000 0000                       | uuuu uuuu                 |
| SCC      | •         | •         | •         | •         | 000- 0000        | 000- 0000                    | 000- 0000                    | 000- 0000                       | uuu- uuuu                 |
| HIRCC    | •         | •         | •         | •         | ---- 0001        | ---- 0001                    | ---- 0001                    | ---- 0001                       | ---- uuuu                 |
| HXTC     | •         | •         | •         | •         | ---- -000        | ---- -000                    | ---- -000                    | ---- -000                       | ---- -uuu                 |
| LXTC     | •         | •         | •         | •         | ---- --00        | ---- --00                    | ---- --00                    | ---- --00                       | ---- --uu                 |
| WDTC     | •         | •         | •         | •         | 0101 0011        | 0101 0011                    | 0101 0011                    | 0101 0011                       | uuuu uuuu                 |
| LVRC     | •         | •         | •         | •         | 0101 0101        | 0101 0101                    | 0101 0101                    | 0101 0101                       | uuuu uuuu                 |
| LVDC     | •         | •         | •         | •         | --00 0000        | --00 0000                    | --00 0000                    | --00 0000                       | --uu uuuu                 |
| EEA      | •         | •         |           |           | 0000 0000        | 0000 0000                    | 0000 0000                    | 0000 0000                       | uuuu uuuu                 |
| EEAL     |           |           | •         | •         | 0000 0000        | 0000 0000                    | 0000 0000                    | 0000 0000                       | uuuu uuuu                 |
| EEAH     |           |           | •         |           | ---- --0         | ---- --0                     | ---- --0                     | ---- --0                        | ---- --u                  |
| EEAH     |           |           |           | •         | ---- --00        | ---- --00                    | ---- --00                    | ---- --00                       | ---- --uu                 |
| EED      | •         | •         | •         | •         | 0000 0000        | 0000 0000                    | 0000 0000                    | 0000 0000                       | uuuu uuuu                 |
| CP0C     | •         | •         | •         | •         | -000 00--        | -000 00--                    | -000 00--                    | -000 00--                       | -uuu uu--                 |
| CP1C     | •         | •         | •         | •         | -000 00--        | -000 00--                    | -000 00--                    | -000 00--                       | -uuu uu--                 |
| PTM0C0   | •         | •         | •         | •         | 0000 0---        | 0000 0---                    | 0000 0---                    | 0000 0---                       | uuuu u---                 |
| PTM0C1   | •         | •         | •         | •         | 0000 0000        | 0000 0000                    | 0000 0000                    | 0000 0000                       | uuuu uuuu                 |
| PTM0DL   | •         | •         | •         | •         | 0000 0000        | 0000 0000                    | 0000 0000                    | 0000 0000                       | uuuu uuuu                 |
| PTM0DH   | •         | •         | •         | •         | ---- --00        | ---- --00                    | ---- --00                    | ---- --00                       | ---- --uu                 |
| PTM0AL   | •         | •         | •         | •         | 0000 0000        | 0000 0000                    | 0000 0000                    | 0000 0000                       | uuuu uuuu                 |
| PTM0AH   | •         | •         | •         | •         | ---- --00        | ---- --00                    | ---- --00                    | ---- --00                       | ---- --uu                 |
| PTM0RPL  | •         | •         | •         | •         | 0000 0000        | 0000 0000                    | 0000 0000                    | 0000 0000                       | uuuu uuuu                 |
| PTM0RPH  | •         | •         | •         | •         | ---- --00        | ---- --00                    | ---- --00                    | ---- --00                       | ---- --uu                 |
| STM0C0   | •         | •         | •         | •         | 0000 0---        | 0000 0---                    | 0000 0---                    | 0000 0---                       | uuuu u---                 |
| STM0C1   | •         | •         | •         | •         | 0000 0000        | 0000 0000                    | 0000 0000                    | 0000 0000                       | uuuu uuuu                 |
| STM0DL   | •         | •         | •         | •         | 0000 0000        | 0000 0000                    | 0000 0000                    | 0000 0000                       | uuuu uuuu                 |
| STM0DH   | •         | •         | •         | •         | 0000 0000        | 0000 0000                    | 0000 0000                    | 0000 0000                       | uuuu uuuu                 |
| STM0AL   | •         | •         | •         | •         | 0000 0000        | 0000 0000                    | 0000 0000                    | 0000 0000                       | uuuu uuuu                 |
| STM0AH   | •         | •         | •         | •         | 0000 0000        | 0000 0000                    | 0000 0000                    | 0000 0000                       | uuuu uuuu                 |
| STM0RP   | •         | •         | •         | •         | 0000 0000        | 0000 0000                    | 0000 0000                    | 0000 0000                       | uuuu uuuu                 |

| Register   | HT66F2350 | HT66F2360 | HT66F2370 | HT66F2390 | Reset (Power On) | RES Reset (Normal Operation) | LVR Reset (Normal Operation) | WDT Time-out (Normal Operation) | WDT Time-out (IDLE/SLEEP)                        |
|------------|-----------|-----------|-----------|-----------|------------------|------------------------------|------------------------------|---------------------------------|--|
| SLEDC0     | •         | •         | •         | •         | 0000 0000        | 0000 0000                    | 0000 0000                    | 0000 0000                       | uuuu uuuu  |
| SLEDC1     | •         | •         | •         | •         | 0000 0000        | 0000 0000                    | 0000 0000                    | 0000 0000                       | uuuu uuuu  |
| SLEDC2     | •         | •         | •         | •         | 0000 0000        | 0000 0000                    | 0000 0000                    | 0000 0000                       | uuuu uuuu  |
| SLEDC3     |           | •         | •         | •         | 0000 0000        | 0000 0000                    | 0000 0000                    | 0000 0000                       | uuuu uuuu  |
| MDUWR0     | •         | •         | •         | •         | xxxx xxxx        | 0000 0000                    | 0000 0000                    | 0000 0000                       | uuuu uuuu  |
| MDUWR1     | •         | •         | •         | •         | xxxx xxxx        | 0000 0000                    | 0000 0000                    | 0000 0000                       | uuuu uuuu  |
| MDUWR2     | •         | •         | •         | •         | xxxx xxxx        | 0000 0000                    | 0000 0000                    | 0000 0000                       | uuuu uuuu  |
| MDUWR3     | •         | •         | •         | •         | xxxx xxxx        | 0000 0000                    | 0000 0000                    | 0000 0000                       | uuuu uuuu  |
| MDUWR4     | •         | •         | •         | •         | xxxx xxxx        | 0000 0000                    | 0000 0000                    | 0000 0000                       | uuuu uuuu  |
| MDUWR5     | •         | •         | •         | •         | xxxx xxxx        | 0000 0000                    | 0000 0000                    | 0000 0000                       | uuuu uuuu  |
| MDUWCTRL   | •         | •         | •         | •         | 00-- ----        | 00-- ----                    | 00-- ----                    | 00-- ----                       | uu-- ----  |
| CP0VOS     | •         | •         | •         | •         | -001 0000        | -001 0000                    | -001 0000                    | -001 0000                       | -uuu uuuu  |
| CP1VOS     | •         | •         | •         | •         | -001 0000        | -001 0000                    | -001 0000                    | -001 0000                       | -uuu uuuu  |
| PSC0R      | •         | •         | •         | •         | ---- --00        | ---- --00                    | ---- --00                    | ---- --00                       | ---- --uu  |
| TB0C       | •         | •         | •         | •         | 0--- -000        | 0--- -000                    | 0--- -000                    | 0--- -000                       | u--- -uuu  |
| TB1C       | •         | •         | •         | •         | 0--- -000        | 0--- -000                    | 0--- -000                    | 0--- -000                       | u--- -uuu  |
| PSC1R      | •         | •         | •         | •         | ---- --00        | ---- --00                    | ---- --00                    | ---- --00                       | ---- --uu  |
| SADOL      | •         | •         | •         | •         | xxxx ----        | xxxx ----                    | xxxx ----                    | xxxx ----                       | uuuu ----<br>(ADRF5=0)<br>uuuu uuuu<br>(ADRF5=0) |
| SADOH      | •         | •         | •         | •         | xxxx xxxx        | uuuu uuuu                    | uuuu uuuu                    | uuuu uuuu                       | uuuu uuuu<br>(ADRF5=0)<br>---- uuuu<br>(ADRF5=0) |
| SADC0      | •         | •         | •         | •         | 0000 0000        | 0000 0000                    | 0000 0000                    | 0000 0000                       | uuuu uuuu  |
| SADC1      | •         | •         | •         | •         | 0000 -000        | 0000 -000                    | 0000 -000                    | 0000 -000                       | uuuu -uuu  |
| SADC2      | •         | •         | •         | •         | 0-00 0000        | 0-00 0000                    | 0-00 0000                    | 0-00 0000                       | u-uu uuuu  |
| SIMC0      | •         | •         | •         | •         | 111- 0000        | 111- 0000                    | 111- 0000                    | 111- 0000                       | uuu- uuuu  |
| SIMC1      | •         | •         | •         | •         | 1000 0001        | 1000 0001                    | 1000 0001                    | 1000 0001                       | uuuu uuuu  |
| SIMD       | •         | •         | •         | •         | xxxx xxxx        | xxxx xxxx                    | xxxx xxxx                    | xxxx xxxx                       | uuuu uuuu  |
| SIMA/SIMC2 | •         | •         | •         | •         | 0000 0000        | 0000 0000                    | 0000 0000                    | 0000 0000                       | uuuu uuuu  |
| SIMTOC     | •         | •         | •         | •         | 0000 0000        | 0000 0000                    | 0000 0000                    | 0000 0000                       | uuuu uuuu  |
| SPIAC0     | •         | •         | •         | •         | 111- --00        | 111- --00                    | 111- --00                    | 111- --00                       | uuu- --uu  |
| SPIAC1     | •         | •         | •         | •         | --00 0000        | --00 0000                    | --00 0000                    | --00 0000                       | --uu uuuu  |
| SPIAD      | •         | •         | •         | •         | xxxx xxxx        | xxxx xxxx                    | xxxx xxxx                    | xxxx xxxx                       | uuuu uuuu  |
| FARL       | •         | •         | •         | •         | 0000 0000        | 0000 0000                    | 0000 0000                    | 0000 0000                       | uuuu uuuu  |
| FARH       | •         |           |           |           | ---0 0000        | ---0 0000                    | ---0 0000                    | ---0 0000                       | ---u uuuu  |
| FARH       |           | •         |           |           | --00 0000        | --00 0000                    | --00 0000                    | --00 0000                       | --uu uuuu  |
| FARH       |           |           | •         |           | -000 0000        | -000 0000                    | -000 0000                    | -000 0000                       | -uuu uuuu  |
| FARH       |           |           |           | •         | 0000 0000        | 0000 0000                    | 0000 0000                    | 0000 0000                       | uuuu uuuu  |
| FD0L       | •         | •         | •         | •         | 0000 0000        | 0000 0000                    | 0000 0000                    | 0000 0000                       | uuuu uuuu  |
| FD0H       | •         | •         | •         | •         | 0000 0000        | 0000 0000                    | 0000 0000                    | 0000 0000                       | uuuu uuuu  |
| FD1L       | •         | •         | •         | •         | 0000 0000        | 0000 0000                    | 0000 0000                    | 0000 0000                       | uuuu uuuu  |
| FD1H       | •         | •         | •         | •         | 0000 0000        | 0000 0000                    | 0000 0000                    | 0000 0000                       | uuuu uuuu  |
| FD2L       | •         | •         | •         | •         | 0000 0000        | 0000 0000                    | 0000 0000                    | 0000 0000                       | uuuu uuuu  |

| Register | HT66F2350 | HT66F2360 | HT66F2370 | HT66F2390 | Reset (Power On) | RES Reset (Normal Operation) | LVR Reset (Normal Operation) | WDT Time-out (Normal Operation) | WDT Time-out (IDLE/SLEEP) |
|----------|-----------|-----------|-----------|-----------|------------------|------------------------------|------------------------------|---------------------------------|---------------------------|
| FD2H     | •         | •         | •         | •         | 0000 0000        | 0000 0000                    | 0000 0000                    | 0000 0000                       | uuuu uuuu                 |
| FD3L     | •         | •         | •         | •         | 0000 0000        | 0000 0000                    | 0000 0000                    | 0000 0000                       | uuuu uuuu                 |
| FD3H     | •         | •         | •         | •         | 0000 0000        | 0000 0000                    | 0000 0000                    | 0000 0000                       | uuuu uuuu                 |
| SCOMC    | •         | •         | •         | •         | -000 ----        | -000 ----                    | -000 ----                    | -000 ----                       | -uuu ----                 |
| CRCCR    | •         | •         | •         | •         | ---- --0         | ---- --0                     | ---- --0                     | ---- --0                        | ---- --u                  |
| CRCIN    | •         | •         | •         | •         | 0000 0000        | 0000 0000                    | 0000 0000                    | 0000 0000                       | uuuu uuuu                 |
| CRCDL    | •         | •         | •         | •         | 0000 0000        | 0000 0000                    | 0000 0000                    | 0000 0000                       | uuuu uuuu                 |
| CRCDH    | •         | •         | •         | •         | 0000 0000        | 0000 0000                    | 0000 0000                    | 0000 0000                       | uuuu uuuu                 |
| IECC     | •         | •         | •         | •         | 0000 0000        | 0000 0000                    | 0000 0000                    | 0000 0000                       | uuuu uuuu                 |
| U0SR     | •         | •         | •         | •         | 0000 1011        | 0000 1011                    | 0000 1011                    | 0000 1011                       | uuuu uuuu                 |
| U0CR1    | •         | •         | •         | •         | 0000 00x0        | 0000 00x0                    | 0000 00x0                    | 0000 00x0                       | uuuu uuuu                 |
| U0CR2    | •         | •         | •         | •         | 0000 0000        | 0000 0000                    | 0000 0000                    | 0000 0000                       | uuuu uuuu                 |
| TXR_RXR0 | •         | •         | •         | •         | xxxx xxxx        | xxxx xxxx                    | xxxx xxxx                    | xxxx xxxx                       | uuuu uuuu                 |
| BRG0     | •         | •         | •         | •         | xxxx xxxx        | xxxx xxxx                    | xxxx xxxx                    | xxxx xxxx                       | uuuu uuuu                 |
| U1SR     | •         | •         | •         | •         | 0000 1011        | 0000 1011                    | 0000 1011                    | 0000 1011                       | uuuu uuuu                 |
| U1CR1    | •         | •         | •         | •         | 0000 00x0        | 0000 00x0                    | 0000 00x0                    | 0000 00x0                       | uuuu uuuu                 |
| U1CR2    | •         | •         | •         | •         | 0000 0000        | 0000 0000                    | 0000 0000                    | 0000 0000                       | uuuu uuuu                 |
| TXR_RXR1 | •         | •         | •         | •         | xxxx xxxx        | xxxx xxxx                    | xxxx xxxx                    | xxxx xxxx                       | uuuu uuuu                 |
| BRG1     | •         | •         | •         | •         | xxxx xxxx        | xxxx xxxx                    | xxxx xxxx                    | xxxx xxxx                       | uuuu uuuu                 |
| U2SR     |           |           | •         | •         | 0000 1011        | 0000 1011                    | 0000 1011                    | 0000 1011                       | uuuu uuuu                 |
| U2CR1    |           |           | •         | •         | 0000 00x0        | 0000 00x0                    | 0000 00x0                    | 0000 00x0                       | uuuu uuuu                 |
| U2CR2    |           |           | •         | •         | 0000 0000        | 0000 0000                    | 0000 0000                    | 0000 0000                       | uuuu uuuu                 |
| TXR_RXR2 |           |           | •         | •         | xxxx xxxx        | xxxx xxxx                    | xxxx xxxx                    | xxxx xxxx                       | uuuu uuuu                 |
| BRG2     |           |           | •         | •         | xxxx xxxx        | xxxx xxxx                    | xxxx xxxx                    | xxxx xxxx                       | uuuu uuuu                 |
| PTM1C0   | •         | •         | •         | •         | 0000 0---        | 0000 0---                    | 0000 0---                    | 0000 0---                       | uuuu u---                 |
| PTM1C1   | •         | •         | •         | •         | 0000 0000        | 0000 0000                    | 0000 0000                    | 0000 0000                       | uuuu uuuu                 |
| PTM1DL   | •         | •         | •         | •         | 0000 0000        | 0000 0000                    | 0000 0000                    | 0000 0000                       | uuuu uuuu                 |
| PTM1DH   | •         | •         | •         | •         | ---- --0         | ---- --0                     | ---- --0                     | ---- --0                        | ---- --uu                 |
| PTM1AL   | •         | •         | •         | •         | 0000 0000        | 0000 0000                    | 0000 0000                    | 0000 0000                       | uuuu uuuu                 |
| PTM1AH   | •         | •         | •         | •         | ---- --0         | ---- --0                     | ---- --0                     | ---- --0                        | ---- --uu                 |
| PTM1RPL  | •         | •         | •         | •         | 0000 0000        | 0000 0000                    | 0000 0000                    | 0000 0000                       | uuuu uuuu                 |
| PTM1RPH  | •         | •         | •         | •         | ---- --0         | ---- --0                     | ---- --0                     | ---- --0                        | ---- --uu                 |
| PTM2C0   | •         | •         | •         | •         | 0000 0---        | 0000 0---                    | 0000 0---                    | 0000 0---                       | uuuu u---                 |
| PTM2C1   | •         | •         | •         | •         | 0000 0000        | 0000 0000                    | 0000 0000                    | 0000 0000                       | uuuu uuuu                 |
| PTM2DL   | •         | •         | •         | •         | 0000 0000        | 0000 0000                    | 0000 0000                    | 0000 0000                       | uuuu uuuu                 |
| PTM2DH   | •         | •         | •         | •         | 0000 0000        | 0000 0000                    | 0000 0000                    | 0000 0000                       | uuuu uuuu                 |
| PTM2AL   | •         | •         | •         | •         | 0000 0000        | 0000 0000                    | 0000 0000                    | 0000 0000                       | uuuu uuuu                 |
| PTM2AH   | •         | •         | •         | •         | 0000 0000        | 0000 0000                    | 0000 0000                    | 0000 0000                       | uuuu uuuu                 |
| PTM2RPL  | •         | •         | •         | •         | 0000 0000        | 0000 0000                    | 0000 0000                    | 0000 0000                       | uuuu uuuu                 |
| PTM2RPH  | •         | •         | •         | •         | 0000 0000        | 0000 0000                    | 0000 0000                    | 0000 0000                       | uuuu uuuu                 |
| PTM3C0   | •         | •         | •         | •         | 0000 0---        | 0000 0---                    | 0000 0---                    | 0000 0---                       | uuuu u---                 |
| PTM3C1   | •         | •         | •         | •         | 0000 0000        | 0000 0000                    | 0000 0000                    | 0000 0000                       | uuuu uuuu                 |
| PTM3DL   | •         | •         | •         | •         | 0000 0000        | 0000 0000                    | 0000 0000                    | 0000 0000                       | uuuu uuuu                 |
| PTM3DH   | •         | •         | •         | •         | 0000 0000        | 0000 0000                    | 0000 0000                    | 0000 0000                       | uuuu uuuu                 |
| PTM3AL   | •         | •         | •         | •         | 0000 0000        | 0000 0000                    | 0000 0000                    | 0000 0000                       | uuuu uuuu                 |

| Register | HT66F2350 | HT66F2360 | HT66F2370 | HT66F2390 | Reset (Power On) | RES Reset (Normal Operation) | LVR Reset (Normal Operation) | WDT Time-out (Normal Operation) | WDT Time-out (IDLE/SLEEP) |
|----------|-----------|-----------|-----------|-----------|------------------|------------------------------|------------------------------|---------------------------------|---------------------------|
| PTM2AH   | •         | •         | •         | •         | 0000 0000        | 0000 0000                    | 0000 0000                    | 0000 0000                       | uuuu uuuu                 |
| PTM3RPL  | •         | •         | •         | •         | 0000 0000        | 0000 0000                    | 0000 0000                    | 0000 0000                       | uuuu uuuu                 |
| PTM3RPH  | •         | •         | •         | •         | 0000 0000        | 0000 0000                    | 0000 0000                    | 0000 0000                       | uuuu uuuu                 |
| STM1C0   | •         | •         | •         | •         | 0000 0---        | 0000 0---                    | 0000 0---                    | 0000 0---                       | uuuu u---                 |
| STM1C1   | •         | •         | •         | •         | 0000 0000        | 0000 0000                    | 0000 0000                    | 0000 0000                       | uuuu uuuu                 |
| STM1DL   | •         | •         | •         | •         | 0000 0000        | 0000 0000                    | 0000 0000                    | 0000 0000                       | uuuu uuuu                 |
| STM1DH   | •         | •         | •         | •         | 0000 0000        | 0000 0000                    | 0000 0000                    | 0000 0000                       | uuuu uuuu                 |
| STM1AL   | •         | •         | •         | •         | 0000 0000        | 0000 0000                    | 0000 0000                    | 0000 0000                       | uuuu uuuu                 |
| STM1AH   | •         | •         | •         | •         | 0000 0000        | 0000 0000                    | 0000 0000                    | 0000 0000                       | uuuu uuuu                 |
| STM1RP   | •         | •         | •         | •         | 0000 0000        | 0000 0000                    | 0000 0000                    | 0000 0000                       | uuuu uuuu                 |
| STM2C0   | •         | •         | •         | •         | 0000 0---        | 0000 0---                    | 0000 0---                    | 0000 0---                       | uuuu u---                 |
| STM2C1   | •         | •         | •         | •         | 0000 0000        | 0000 0000                    | 0000 0000                    | 0000 0000                       | uuuu uuuu                 |
| STM2DL   | •         | •         | •         | •         | 0000 0000        | 0000 0000                    | 0000 0000                    | 0000 0000                       | uuuu uuuu                 |
| STM2DH   | •         | •         | •         | •         | 0000 0000        | 0000 0000                    | 0000 0000                    | 0000 0000                       | uuuu uuuu                 |
| STM2AL   | •         | •         | •         | •         | 0000 0000        | 0000 0000                    | 0000 0000                    | 0000 0000                       | uuuu uuuu                 |
| STM2AH   | •         | •         | •         | •         | 0000 0000        | 0000 0000                    | 0000 0000                    | 0000 0000                       | uuuu uuuu                 |
| STM2RP   | •         | •         | •         | •         | 0000 0000        | 0000 0000                    | 0000 0000                    | 0000 0000                       | uuuu uuuu                 |
| EEC      | •         | •         | •         | •         | ---- 0000        | ---- 0000                    | ---- 0000                    | ---- 0000                       | ---- uuuu                 |
| FC0      | •         | •         | •         | •         | 0000 0000        | 0000 0000                    | 0000 0000                    | 0000 0000                       | uuuu uuuu                 |
| FC1      | •         | •         | •         | •         | 0000 0000        | 0000 0000                    | 0000 0000                    | 0000 0000                       | uuuu uuuu                 |
| FC2      | •         | •         | •         | •         | ---- --0         | ---- --0                     | ---- --0                     | ---- --0                        | ---- --u                  |
| IFS0     | •         | •         | •         | •         | -000 0000        | -000 0000                    | -000 0000                    | -000 0000                       | -uuu uuuu                 |
| IFS1     | •         | •         | •         | •         | -000 0000        | -000 0000                    | -000 0000                    | -000 0000                       | -uuu uuuu                 |
| IFS2     | •         | •         | •         | •         | -000 0000        | -000 0000                    | -000 0000                    | -000 0000                       | -uuu uuuu                 |
| IFS3     | •         | •         |           |           | ---- --00        | ---- --00                    | ---- --00                    | ---- --00                       | ---- --uu                 |
| IFS3     |           |           | •         | •         | ---- -000        | ---- -000                    | ---- -000                    | ---- -000                       | ---- -uuu                 |
| PAS0     | •         | •         | •         | •         | 0000 0000        | 0000 0000                    | 0000 0000                    | 0000 0000                       | uuuu uuuu                 |
| PAS1     | •         | •         | •         | •         | 0000 0000        | 0000 0000                    | 0000 0000                    | 0000 0000                       | uuuu uuuu                 |
| PBS0     | •         | •         | •         | •         | 0000 0000        | 0000 0000                    | 0000 0000                    | 0000 0000                       | uuuu uuuu                 |
| PBS1     | •         | •         | •         | •         | 0000 0000        | 0000 0000                    | 0000 0000                    | 0000 0000                       | uuuu uuuu                 |
| PCS0     | •         | •         | •         | •         | 0000 0000        | 0000 0000                    | 0000 0000                    | 0000 0000                       | uuuu uuuu                 |
| PCS1     | •         | •         | •         | •         | 0000 0000        | 0000 0000                    | 0000 0000                    | 0000 0000                       | uuuu uuuu                 |
| PDS0     | •         | •         | •         | •         | 0000 0000        | 0000 0000                    | 0000 0000                    | 0000 0000                       | uuuu uuuu                 |
| PDS1     | •         | •         | •         | •         | --00 0000        | --00 0000                    | --00 0000                    | --00 0000                       | --uu uuuu                 |
| PES0     | •         | •         | •         | •         | 0000 0000        | 0000 0000                    | 0000 0000                    | 0000 0000                       | uuuu uuuu                 |
| PES1     | •         | •         | •         | •         | ---- --00        | ---- --00                    | ---- --00                    | ---- --00                       | ---- --uu                 |
| PFS0     | •         | •         | •         | •         | 0000 0000        | 0000 0000                    | 0000 0000                    | 0000 0000                       | uuuu uuuu                 |
| PFS1     | •         | •         | •         | •         | 0000 0000        | 0000 0000                    | 0000 0000                    | 0000 0000                       | uuuu uuuu                 |
| PGS0     |           | •         | •         | •         | 0000 0000        | 0000 0000                    | 0000 0000                    | 0000 0000                       | uuuu uuuu                 |
| PGS1     |           | •         | •         | •         | 0000 0000        | 0000 0000                    | 0000 0000                    | 0000 0000                       | uuuu uuuu                 |
| PHS0     |           | •         | •         | •         | 0000 0000        | 0000 0000                    | 0000 0000                    | 0000 0000                       | uuuu uuuu                 |
| PHS1     |           | •         | •         | •         | ---- 0000        | ---- 0000                    | ---- 0000                    | ---- 0000                       | ---- uuuu                 |

Note: "u" stands for unchanged  
"x" stands for "unknown"  
"-" stands for unimplemented

## Input/Output Ports

Holtek microcontrollers offer considerable flexibility on their I/O ports. With the input or output designation of every pin fully under user program control, pull-high selections for all ports and wake-up selections on certain pins, the user is provided with an I/O structure to meet the needs of a wide range of application possibilities.

These devices provide bidirectional input/output lines. These I/O ports are mapped to the RAM Data Memory with specific addresses as shown in the Special Purpose Data Memory table. All of these I/O ports can be used for input and output operations. For input operation, these ports are non-latching, which means the inputs must be ready at the T2 rising edge of instruction "MOV A, [m]", where m denotes the port address. For output operation, all the data is latched and remains unchanged until the output latch is rewritten.

| Register Name | Bit   |       |       |       |       |       |       |       |
|---------------|-------|-------|-------|-------|-------|-------|-------|-------|
|               | 7     | 6     | 5     | 4     | 3     | 2     | 1     | 0     |
| PA            | PA7   | PA6   | PA5   | PA4   | PA3   | PA2   | PA1   | PA0   |
| PAC           | PAC7  | PAC6  | PAC5  | PAC4  | PAC3  | PAC2  | PAC1  | PAC0  |
| PAPU          | PAPU7 | PAPU6 | PAPU5 | PAPU4 | PAPU3 | PAPU2 | PAPU1 | PAPU0 |
| PAWU          | PAWU7 | PAWU6 | PAWU5 | PAWU4 | PAWU3 | PAWU2 | PAWU1 | PAWU0 |
| PB            | PB7   | PB6   | PB5   | PB4   | PB3   | PB2   | PB1   | PB0   |
| PBC           | PBC7  | PBC6  | PBC5  | PBC4  | PBC3  | PBC2  | PBC1  | PBC0  |
| PBPU          | PBPU7 | PBPU6 | PBPU5 | PBPU4 | PBPU3 | PBPU2 | PBPU1 | PBPU0 |
| PC            | PC7   | PC6   | PC5   | PC4   | PC3   | PC2   | PC1   | PC0   |
| PCC           | PCC7  | PCC6  | PCC5  | PCC4  | PCC3  | PCC2  | PCC1  | PCC0  |
| PCPU          | PCPU7 | PCPU6 | PCPU5 | PCPU4 | PCPU3 | PCPU2 | PCPU1 | PCPU0 |
| PD            | —     | PD6   | PD5   | PD4   | PD3   | PD2   | PD1   | PD0   |
| PDC           | —     | PDC6  | PDC5  | PDC4  | PDC3  | PDC2  | PDC1  | PDC0  |
| PDPU          | —     | PDPU6 | PDPU5 | PDPU4 | PDPU3 | PDPU2 | PDPU1 | PDPU0 |
| PE            | —     | —     | —     | PE4   | PE3   | PE2   | PE1   | PE0   |
| PEC           | —     | —     | —     | PEC4  | PEC3  | PEC2  | PEC1  | PEC0  |
| PEPU          | —     | —     | —     | PEPU4 | PEPU3 | PEPU2 | PEPU1 | PEPU0 |
| PF            | PF7   | PF6   | PF5   | PF4   | PF3   | PF2   | PF1   | PF0   |
| PFC           | PFC7  | PFC6  | PFC5  | PFC4  | PFC3  | PFC2  | PFC1  | PFC0  |
| PFPU          | PFPU7 | PFPU6 | PFPU5 | PFPU4 | PFPU3 | PFPU2 | PFPU1 | PFPU0 |

"—": Unimplemented, read as "0"

**I/O Logic Function Registers List – HT66F2350**

| Register Name | Bit   |       |       |       |       |       |       |       |
|---------------|-------|-------|-------|-------|-------|-------|-------|-------|
|               | 7     | 6     | 5     | 4     | 3     | 2     | 1     | 0     |
| PA            | PA7   | PA6   | PA5   | PA4   | PA3   | PA2   | PA1   | PA0   |
| PAC           | PAC7  | PAC6  | PAC5  | PAC4  | PAC3  | PAC2  | PAC1  | PAC0  |
| PAPU          | PAPU7 | PAPU6 | PAPU5 | PAPU4 | PAPU3 | PAPU2 | PAPU1 | PAPU0 |
| PAWU          | PAWU7 | PAWU6 | PAWU5 | PAWU4 | PAWU3 | PAWU2 | PAWU1 | PAWU0 |
| PB            | PB7   | PB6   | PB5   | PB4   | PB3   | PB2   | PB1   | PB0   |
| PBC           | PBC7  | PBC6  | PBC5  | PBC4  | PBC3  | PBC2  | PBC1  | PBC0  |
| PBPU          | PBPU7 | PBPU6 | PBPU5 | PBPU4 | PBPU3 | PBPU2 | PBPU1 | PBPU0 |
| PC            | PC7   | PC6   | PC5   | PC4   | PC3   | PC2   | PC1   | PC0   |
| PCC           | PCC7  | PCC6  | PCC5  | PCC4  | PCC3  | PCC2  | PCC1  | PCC0  |
| PCPU          | PCPU7 | PCPU6 | PCPU5 | PCPU4 | PCPU3 | PCPU2 | PCPU1 | PCPU0 |
| PD            | —     | PD6   | PD5   | PD4   | PD3   | PD2   | PD1   | PD0   |
| PDC           | —     | PDC6  | PDC5  | PDC4  | PDC3  | PDC2  | PDC1  | PDC0  |
| PDPU          | —     | PDPU6 | PDPU5 | PDPU4 | PDPU3 | PDPU2 | PDPU1 | PDPU0 |
| PE            | —     | —     | —     | PE4   | PE3   | PE2   | PE1   | PE0   |
| PEC           | —     | —     | —     | PEC4  | PEC3  | PEC2  | PEC1  | PEC0  |
| PEPU          | —     | —     | —     | PEPU4 | PEPU3 | PEPU2 | PEPU1 | PEPU0 |
| PF            | PF7   | PF6   | PF5   | PF4   | PF3   | PF2   | PF1   | PF0   |
| PFC           | PFC7  | PFC6  | PFC5  | PFC4  | PFC3  | PFC2  | PFC1  | PFC0  |
| PFPU          | PFPU7 | PFPU6 | PFPU5 | PFPU4 | PFPU3 | PFPU2 | PFPU1 | PFPU0 |
| PG            | PG7   | PG6   | PG5   | PG4   | PG3   | PG2   | PG1   | PG0   |
| PGC           | PGC7  | PGC6  | PGC5  | PGC4  | PGC3  | PGC2  | PGC1  | PGC0  |
| PGPU          | PGPU7 | PGPU6 | PGPU5 | PGPU4 | PGPU3 | PGPU2 | PGPU1 | PGPU0 |
| PH            | —     | —     | PH5   | PH4   | PH3   | PH2   | PH1   | PH0   |
| PHC           | —     | —     | PHC5  | PHC4  | PHC3  | PHC2  | PHC1  | PHC0  |
| PHPU          | —     | —     | PHPU5 | PHPU4 | PHPU3 | PHPU2 | PHPU1 | PHPU0 |

"—": Unimplemented, read as "0"

**I/O Logic Function Registers List – HT66F2360/HT66F2370/HT66F2390**

**Pull-high Resistors**

Many product applications require pull-high resistors for their switch inputs usually requiring the use of an external resistor. To eliminate the need for these external resistors, all I/O pins, when configured as an input have the capability of being connected to an internal pull-high resistor. These pull-high resistors are selected using the relevant pull-high control registers and are implemented using weak PMOS transistors. Note that the pull-high resistor can be controlled by the relevant pull-high control register only when the pin-shared functional pin is selected as an input or NMOS output. Otherwise, the pull-high resistors can not be enabled.

• **PxPU Register**

| Bit  | 7     | 6     | 5     | 4     | 3     | 2     | 1     | 0     |
|------|-------|-------|-------|-------|-------|-------|-------|-------|
| Name | PxPU7 | PxPU6 | PxPU5 | PxPU4 | PxPU3 | PxPU2 | PxPU1 | PxPU0 |
| R/W  | R/W   | R/W   | R/W   | R/W   | R/W   | R/W   | R/W   | R/W   |
| POR  | 0     | 0     | 0     | 0     | 0     | 0     | 0     | 0     |

**PxPUn:** I/O Port x Pin pull-high function control

0: Disable

1: Enable

The PxPUn bit is used to control the pin pull-high function. Here the "x" is the Port name which can be A, B, C, D, E, F, G and H depending upon the selected device. However, the actual available bits for each I/O Port may be different.

## Port A Wake-up

The HALT instruction forces the microcontroller into the SLEEP or IDLE Mode which preserves power, a feature that is important for battery and other low-power applications. Various methods exist to wake-up the microcontroller, one of which is to change the logic condition on one of the Port A pins from high to low. This function is especially suitable for applications that can be woken up via external switches. Each pin on Port A can be selected individually to have this wake-up feature using the PAWU register. Note that the wake-up function can be controlled by the wake-up control registers only when the pin-shared functional pin is selected as general purpose input/output and the MCU enters the Power down mode.

### • PAWU Register

| Bit  | 7     | 6     | 5     | 4     | 3     | 2     | 1     | 0     |
|------|-------|-------|-------|-------|-------|-------|-------|-------|
| Name | PAWU7 | PAWU6 | PAWU5 | PAWU4 | PAWU3 | PAWU2 | PAWU1 | PAWU0 |
| R/W  | R/W   | R/W   | R/W   | R/W   | R/W   | R/W   | R/W   | R/W   |
| POR  | 0     | 0     | 0     | 0     | 0     | 0     | 0     | 0     |

Bit 7~0 **PAWU7~PAWU0**: Port A pin Wake-up function control  
 0: Disable  
 1: Enable

## I/O Port Control Registers

Each Port has its own control register which controls the input/output configuration. With this control register, each I/O pin with or without pull-high resistors can be reconfigured dynamically under software control. For the I/O pin to function as an input, the corresponding bit of the control register must be written as a "1". This will then allow the logic state of the input pin to be directly read by instructions. When the corresponding bit of the control register is written as a "0", the I/O pin will be setup as a CMOS output. If the pin is currently setup as an output, instructions can still be used to read the output register.

However, it should be noted that the program will in fact only read the status of the output data latch and not the actual logic status of the output pin.

### • PxC Register

| Bit  | 7    | 6    | 5    | 4    | 3    | 2    | 1    | 0    |
|------|------|------|------|------|------|------|------|------|
| Name | PxC7 | PxC6 | PxC5 | PxC4 | PxC3 | PxC2 | PxC1 | PxC0 |
| R/W  | R/W  | R/W  | R/W  | R/W  | R/W  | R/W  | R/W  | R/W  |
| POR  | 1    | 1    | 1    | 1    | 1    | 1    | 1    | 1    |

**PxCn**: I/O Port × Pin type selection  
 0: Output  
 1: Input

The PxCn bit is used to control the pin type selection. Here the "x" is the Port name which can be A, B, C, D, E, F, G and H depending upon the selected device. However, the actual available bits for each I/O Port may be different.

## I/O Port Source Current Control

These devices support different source current driving capability for each I/O port. With the selection register, SLEDCn, specific I/O port can support four levels of the source current driving capability. Users should refer to the I/O Port characteristics section to select the desired source current for different applications.

| Register Name | Bit     |         |         |         |         |         |         |         |
|---------------|---------|---------|---------|---------|---------|---------|---------|---------|
|               | 7       | 6       | 5       | 4       | 3       | 2       | 1       | 0       |
| SLEDC0        | SLEDC07 | SLEDC06 | SLEDC05 | SLEDC04 | SLEDC03 | SLEDC02 | SLEDC01 | SLEDC00 |
| SLEDC1        | SLEDC17 | SLEDC16 | SLEDC15 | SLEDC14 | SLEDC13 | SLEDC12 | SLEDC11 | SLEDC10 |
| SLEDC2        | SLEDC27 | SLEDC26 | SLEDC25 | SLEDC24 | SLEDC23 | SLEDC22 | SLEDC21 | SLEDC20 |

**I/O Port Source Current Control Registers List – HT66F2350**

| Register Name | Bit     |         |         |         |         |         |         |         |
|---------------|---------|---------|---------|---------|---------|---------|---------|---------|
|               | 7       | 6       | 5       | 4       | 3       | 2       | 1       | 0       |
| SLEDC0        | SLEDC07 | SLEDC06 | SLEDC05 | SLEDC04 | SLEDC03 | SLEDC02 | SLEDC01 | SLEDC00 |
| SLEDC1        | SLEDC17 | SLEDC16 | SLEDC15 | SLEDC14 | SLEDC13 | SLEDC12 | SLEDC11 | SLEDC10 |
| SLEDC2        | SLEDC27 | SLEDC26 | SLEDC25 | SLEDC24 | SLEDC23 | SLEDC22 | SLEDC21 | SLEDC20 |
| SLEDC3        | SLEDC37 | SLEDC36 | SLEDC35 | SLEDC34 | SLEDC33 | SLEDC32 | SLEDC31 | SLEDC30 |

**I/O Port Source Current Control Registers List – HT66F2360/HT66F2370/HT66F2390**

### • SLEDC0 Register

| Bit  | 7       | 6       | 5       | 4       | 3       | 2       | 1       | 0       |
|------|---------|---------|---------|---------|---------|---------|---------|---------|
| Name | SLEDC07 | SLEDC06 | SLEDC05 | SLEDC04 | SLEDC03 | SLEDC02 | SLEDC01 | SLEDC00 |
| R/W  | R/W     | R/W     | R/W     | R/W     | R/W     | R/W     | R/W     | R/W     |
| POR  | 0       | 0       | 0       | 0       | 0       | 0       | 0       | 0       |

- Bit 7~6     **SLEDC07~SLEDC06:** PB7~PB4 source current selection  
00: source current=Level 0 (min.)  
01: source current=Level 1  
10: source current=Level 2  
11: source current=Level 3 (max.)
- Bit 5~4     **SLEDC05~SLEDC04:** PB3~PB0 source current selection  
00: source current=Level 0 (min.)  
01: source current=Level 1  
10: source current=Level 2  
11: source current=Level 3 (max.)
- Bit 3~2     **SLEDC03~SLEDC02:** PA7~PA4 source current selection  
00: source current=Level 0 (min.)  
01: source current=Level 1  
10: source current=Level 2  
11: source current=Level 3 (max.)
- Bit 1~0     **SLEDC01~SLEDC00:** PA3~PA0 source current selection  
00: source current=Level 0 (min.)  
01: source current=Level 1  
10: source current=Level 2  
11: source current=Level 3 (max.)

• **SLEDC1 Register**

| Bit  | 7       | 6       | 5       | 4       | 3       | 2       | 1       | 0       |
|------|---------|---------|---------|---------|---------|---------|---------|---------|
| Name | SLEDC17 | SLEDC16 | SLEDC15 | SLEDC14 | SLEDC13 | SLEDC12 | SLEDC11 | SLEDC10 |
| R/W  | R/W     | R/W     | R/W     | R/W     | R/W     | R/W     | R/W     | R/W     |
| POR  | 0       | 0       | 0       | 0       | 0       | 0       | 0       | 0       |

- Bit 7~6     **SLEDC17~SLEDC16:** PD6~PD4 source current selection  
00: source current=Level 0 (min.)  
01: source current=Level 1  
10: source current=Level 2  
11: source current=Level 3 (max.)
- Bit 5~4     **SLEDC15~SLEDC14:** PD3~PD0 source current selection  
00: source current=Level 0 (min.)  
01: source current=Level 1  
10: source current=Level 2  
11: source current=Level 3 (max.)
- Bit 3~2     **SLEDC13~SLEDC12:** PC7~PC4 source current selection  
00: source current=Level 0 (min.)  
01: source current=Level 1  
10: source current=Level 2  
11: source current=Level 3 (max.)
- Bit 1~0     **SLEDC11~SLEDC10:** PC3~PC0 source current selection  
00: source current=Level 0 (min.)  
01: source current=Level 1  
10: source current=Level 2  
11: source current=Level 3 (max.)

• **SLEDC2 Register**

| Bit  | 7       | 6       | 5       | 4       | 3       | 2       | 1       | 0       |
|------|---------|---------|---------|---------|---------|---------|---------|---------|
| Name | SLEDC27 | SLEDC26 | SLEDC25 | SLEDC24 | SLEDC23 | SLEDC22 | SLEDC21 | SLEDC20 |
| R/W  | R/W     | R/W     | R/W     | R/W     | R/W     | R/W     | R/W     | R/W     |
| POR  | 0       | 0       | 0       | 0       | 0       | 0       | 0       | 0       |

- Bit 7~6     **SLEDC27~SLEDC26:** PF7~PF4 source current selection  
00: source current=Level 0 (min.)  
01: source current=Level 1  
10: source current=Level 2  
11: source current=Level 3 (max.)
- Bit 5~4     **SLEDC25~SLEDC24:** PF3~PF0 source current selection  
00: source current=Level 0 (min.)  
01: source current=Level 1  
10: source current=Level 2  
11: source current=Level 3 (max.)
- Bit 3~2     **SLEDC23~SLEDC22:** PE4 source current selection  
00: source current=Level 0 (min.)  
01: source current=Level 1  
10: source current=Level 2  
11: source current=Level 3 (max.)
- Bit 1~0     **SLEDC21~SLEDC20:** PE3~PE0 source current selection  
00: source current=Level 0 (min.)  
01: source current=Level 1  
10: source current=Level 2  
11: source current=Level 3 (max.)

• **SLEDC3 Register – HT66F2360/HT66F2370/HT66F2390**

| Bit  | 7       | 6       | 5       | 4       | 3       | 2       | 1       | 0       |
|------|---------|---------|---------|---------|---------|---------|---------|---------|
| Name | SLEDC37 | SLEDC36 | SLEDC35 | SLEDC34 | SLEDC33 | SLEDC32 | SLEDC31 | SLEDC30 |
| R/W  | R/W     | R/W     | R/W     | R/W     | R/W     | R/W     | R/W     | R/W     |
| POR  | 0       | 0       | 0       | 0       | 0       | 0       | 0       | 0       |

- Bit 7~6     **SLEDC37~SLEDC36:** PH5~PH4 source current selection  
00: source current=Level 0 (min.)  
01: source current=Level 1  
10: source current=Level 2  
11: source current=Level 3 (max.)
- Bit 5~4     **SLEDC35~SLEDC34:** PH3~PH0 source current selection  
00: source current=Level 0 (min.)  
01: source current=Level 1  
10: source current=Level 2  
11: source current=Level 3 (max.)
- Bit 3~2     **SLEDC33~SLEDC32:** PG7~PG4 source current selection  
00: source current=Level 0 (min.)  
01: source current=Level 1  
10: source current=Level 2  
11: source current=Level 3 (max.)
- Bit 1~0     **SLEDC31~SLEDC30:** PG3~PG0 source current selection  
00: source current=Level 0 (min.)  
01: source current=Level 1  
10: source current=Level 2  
11: source current=Level 3 (max.)

**I/O Port Power Source Control**

These devices support different I/O port power source selections for PE3~PE0. The port power can come from either the power pin VDD or VDDIO which is determined using the PMPS1~PMPS0 bits in the PMPS register. The VDDIO power pin function should first be selected using the corresponding pin-shared function selection bits if the port power is supposed to come from the VDDIO pin. An important point to know is that the input power voltage on the VDDIO pin should be equal to or less than the device supply power voltage when the VDDIO pin is selected as the port power supply pin.

• **PMPS Register**

| Bit  | 7 | 6 | 5 | 4 | 3 | 2 | 1     | 0     |
|------|---|---|---|---|---|---|-------|-------|
| Name | — | — | — | — | — | — | PMPS1 | PMPS0 |
| R/W  | — | — | — | — | — | — | R/W   | R/W   |
| POR  | — | — | — | — | — | — | 0     | 0     |

- Bit 7~2     Unimplemented, read as "0"
- Bit 1~0     **PMPS1~PMPS0:** PE3~PE0 pin power source selection  
0x: VDD  
1x: VDDIO

## **Pin-shared Functions**

The flexibility of the microcontroller range is greatly enhanced by the use of pins that have more than one function. Limited numbers of pins can force serious design constraints on designers but by supplying pins with multi-functions, many of these difficulties can be overcome. For these pins, the desired function of the multi-function I/O pins is selected by a series of registers via the application program control.

### **Pin-shared Function Selection Registers**

The limited number of supplied pins in a package can impose restrictions on the amount of functions a certain device can contain. However by allowing the same pins to share several different functions and providing a means of function selection, a wide range of different functions can be incorporated into even relatively small package sizes. Each device includes Port "x" output function Selection register "n", labeled as P<sub>x</sub>S<sub>n</sub>, and Input Function Selection register, labeled as IFS<sub>n</sub>, which can select the desired functions of the multi-function pin-shared pins.

When the pin-shared input function is selected to be used, the corresponding input and output functions selection should be properly managed. For example, if the I<sup>2</sup>C SDA line is used, the corresponding output pin-shared function should be configured as the SDI/SDA function by configuring the P<sub>x</sub>S<sub>n</sub> register and the SDA signal input should be properly selected using the IFS<sub>n</sub> register. However, if the external interrupt function is selected to be used, the relevant output pin-shared function should be selected as an I/O function and the interrupt input signal should be selected.

The most important point to note is to make sure that the desired pin-shared function is properly selected and also deselected. For most pin-shared functions, to select the desired pin-shared function, the pin-shared function should first be correctly selected using the corresponding pin-shared control register. After that the corresponding peripheral functional setting should be configured and then the peripheral function can be enabled. However, special point must be noted for some digital input pins, such as INT<sub>n</sub>, xTCK<sub>n</sub>, xTPnI, etc, which share the same pin-shared control configuration with their corresponding general purpose I/O functions when setting the relevant pin-shared control bit fields. To select these pin functions, in addition to the necessary pin-shared control and peripheral functional setup aforementioned, they must also be setup as input by setting the corresponding bit in the I/O port control register. To correctly deselect the pin-shared function, the peripheral function should first be disabled and then the corresponding pin-shared function control register can be modified to select other pin-shared functions.

| Register Name             | Bit   |         |          |          |         |         |         |         |
|---------------------------|-------|---------|----------|----------|---------|---------|---------|---------|
|                           | 7     | 6       | 5        | 4        | 3       | 2       | 1       | 0       |
| PAS0                      | PAS07 | PAS06   | PAS05    | PAS04    | PAS03   | PAS02   | PAS01   | PAS00   |
| PAS1                      | PAS17 | PAS16   | PAS15    | PAS14    | PAS13   | PAS12   | PAS11   | PAS10   |
| PBS0                      | PBS07 | PBS06   | PBS05    | PBS04    | PBS03   | PBS02   | PBS01   | PBS00   |
| PBS1                      | PBS17 | PBS16   | PBS15    | PBS14    | PBS13   | PBS12   | PBS11   | PBS10   |
| PCS0                      | PCS07 | PCS06   | PCS05    | PCS04    | PCS03   | PCS02   | PCS01   | PCS00   |
| PCS1                      | PCS17 | PCS16   | PCS15    | PCS14    | PCS13   | PCS12   | PCS11   | PCS10   |
| PDS0                      | PDS07 | PDS06   | PDS05    | PDS04    | PDS03   | PDS02   | PDS01   | PDS00   |
| PDS1                      | —     | —       | PDS15    | PDS14    | PDS13   | PDS12   | PDS11   | PDS10   |
| PES0                      | PES07 | PES06   | PES05    | PES04    | PES03   | PES02   | PES01   | PES00   |
| PES1                      | —     | —       | —        | —        | —       | —       | PES11   | PES10   |
| PFS0                      | PFS07 | PFS06   | PFS05    | PFS04    | PFS03   | PFS02   | PFS01   | PFS00   |
| PFS1                      | PFS17 | PFS16   | PFS15    | PFS14    | PFS13   | PFS12   | PFS11   | PFS10   |
| PGS0<br>(HT66F2360/70/90) | PGS07 | PGS06   | PGS05    | PGS04    | PGS03   | PGS02   | PGS01   | PGS00   |
| PGS1<br>(HT66F2360/70/90) | PGS17 | PGS16   | PGS15    | PGS14    | PGS13   | PGS12   | PGS11   | PGS10   |
| PHS0<br>(HT66F2360/70/90) | PHS07 | PHS06   | PHS05    | PHS04    | PHS03   | PHS02   | PHS01   | PHS00   |
| PHS1<br>(HT66F2360/70/90) | —     | —       | —        | —        | PHS13   | PHS12   | PHS11   | PHS10   |
| IFS0                      | —     | PTCK3PS | PTCK2PS  | PTCK1PS  | PTCK0PS | STCK2PS | STCK1PS | STCK0PS |
| IFS1                      | —     | PTP3IPS | PTP2IPS  | PTP1IPS  | PTP0IPS | STP2IPS | STP1IPS | STP0IPS |
| IFS2                      | —     | SCSBPS  | SDISDAPS | SCKSCLPS | INT3PS  | INT2PS  | INT1PS  | INT0PS  |
| IFS3 (HT66F2350/60)       | —     | —       | —        | —        | —       | —       | RX1PS   | RX0PS   |
| IFS3 (HT66F2370/90)       | —     | —       | —        | —        | —       | RX2PS   | RX1PS   | RX0PS   |

**Pin-shared Function Selection Registers List**

• **PAS0 Register**

| Bit  | 7     | 6     | 5     | 4     | 3     | 2     | 1     | 0     |
|------|-------|-------|-------|-------|-------|-------|-------|-------|
| Name | PAS07 | PAS06 | PAS05 | PAS04 | PAS03 | PAS02 | PAS01 | PAS00 |
| R/W  | R/W   | R/W   | R/W   | R/W   | R/W   | R/W   | R/W   | R/W   |
| POR  | 0     | 0     | 0     | 0     | 0     | 0     | 0     | 0     |

- Bit 7~6     **PAS07~PAS06:** PA3 pin function selection  
00, 01, 10: PA3/INT1  
11: SDO
- Bit 5~4     **PAS05~PAS04:** PA2 pin function selection  
00, 01, 10, 11: PA2
- Bit 3~2     **PAS03~PAS02:** PA1 pin function selection  
00, 01, 10: PA1/INT0  
11:  $\overline{SCS}$
- Bit 1~0     **PAS01~PAS00:** PA0 pin function selection  
00, 01, 10, 11: PA0

• **PAS1 Register**

| Bit  | 7     | 6     | 5     | 4     | 3     | 2     | 1     | 0     |
|------|-------|-------|-------|-------|-------|-------|-------|-------|
| Name | PAS17 | PAS16 | PAS15 | PAS14 | PAS13 | PAS12 | PAS11 | PAS10 |
| R/W  | R/W   | R/W   | R/W   | R/W   | R/W   | R/W   | R/W   | R/W   |
| POR  | 0     | 0     | 0     | 0     | 0     | 0     | 0     | 0     |

- Bit 7~6     **PAS17~PAS16:** PA7 pin function selection  
00, 01, 10: PA7/INT1  
11: TX0
- Bit 5~4     **PAS15~PAS14:** PA6 pin function selection  
00, 01, 10: PA6/INT0  
11: RX0
- Bit 3~2     **PAS13~PAS12:** PA5 pin function selection  
00, 01, 10: PA5/INT3  
11: SCK/SCL
- Bit 1~0     **PAS11~PAS10:** PA4 pin function selection  
00, 01, 10: PA4/INT2  
11: SDI/SDA

• **PBS0 Register – HT66F2350/HT66F2360**

| Bit  | 7     | 6     | 5     | 4     | 3     | 2     | 1     | 0     |
|------|-------|-------|-------|-------|-------|-------|-------|-------|
| Name | PBS07 | PBS06 | PBS05 | PBS04 | PBS03 | PBS02 | PBS01 | PBS00 |
| R/W  | R/W   | R/W   | R/W   | R/W   | R/W   | R/W   | R/W   | R/W   |
| POR  | 0     | 0     | 0     | 0     | 0     | 0     | 0     | 0     |

- Bit 7~6     **PBS07~PBS06:** PB3 pin function selection  
00, 01, 10: PB3/PTP21  
11: PTP2
- Bit 5~4     **PBS05~PBS04:** PB2 pin function selection  
00, 01, 10: PB2/PTP31/PTCK2  
11: PTP3
- Bit 3~2     **PBS03~PBS02:** PB1 pin function selection  
00, 01, 10, 11: PB1/PTCK3
- Bit 1~0     **PBS01~PBS00:** PB0 pin function selection  
00, 01, 10: PB0/STCK2  
11: C0X

• **PBS0 Register – HT66F2370/HT66F2390**

| Bit  | 7     | 6     | 5     | 4     | 3     | 2     | 1     | 0     |
|------|-------|-------|-------|-------|-------|-------|-------|-------|
| Name | PBS07 | PBS06 | PBS05 | PBS04 | PBS03 | PBS02 | PBS01 | PBS00 |
| R/W  | R/W   | R/W   | R/W   | R/W   | R/W   | R/W   | R/W   | R/W   |
| POR  | 0     | 0     | 0     | 0     | 0     | 0     | 0     | 0     |

- Bit 7~6     **PBS07~PBS06:** PB3 pin function selection  
00, 01, 10: PB3/PTP21  
11: PTP2
- Bit 5~4     **PBS05~PBS04:** PB2 pin function selection  
00, 01: PB2/PTP31/PTCK2  
10: RX2  
11: PTP3
- Bit 3~2     **PBS03~PBS02:** PB1 pin function selection  
00, 01, 10: PB1/PTCK3  
11: TX2
- Bit 1~0     **PBS01~PBS00:** PB0 pin function selection  
00, 01, 10: PB0/STCK2  
11: C0X

• **PBS1 Register**

| Bit  | 7     | 6     | 5     | 4     | 3     | 2     | 1     | 0     |
|------|-------|-------|-------|-------|-------|-------|-------|-------|
| Name | PBS17 | PBS16 | PBS15 | PBS14 | PBS13 | PBS12 | PBS11 | PBS10 |
| R/W  | R/W   | R/W   | R/W   | R/W   | R/W   | R/W   | R/W   | R/W   |
| POR  | 0     | 0     | 0     | 0     | 0     | 0     | 0     | 0     |

- Bit 7~6     **PBS17~PBS16:** PB7 pin function selection  
00, 01, 10: PB7/STCK1  
11: OSC2
- Bit 5~4     **PBS15~PBS14:** PB6 pin function selection  
00, 01: PB6/STP1I  
10: STP1  
11: OSC1
- Bit 3~2     **PBS13~PBS12:** PB5 pin function selection  
00, 01, 10, 11: PB5/RES
- Bit 1~0     **PBS11~PBS10:** PB4 pin function selection  
00, 01, 10: PB4  
11: C1X

• **PCS0 Register**

| Bit  | 7     | 6     | 5     | 4     | 3     | 2     | 1     | 0     |
|------|-------|-------|-------|-------|-------|-------|-------|-------|
| Name | PCS07 | PCS06 | PCS05 | PCS04 | PCS03 | PCS02 | PCS01 | PCS00 |
| R/W  | R/W   | R/W   | R/W   | R/W   | R/W   | R/W   | R/W   | R/W   |
| POR  | 0     | 0     | 0     | 0     | 0     | 0     | 0     | 0     |

- Bit 7~6     **PCS07~PCS06:** PC3 pin function selection  
00, 01, 10: PC3/PTCK0  
11: AN3
- Bit 5~4     **PCS05~PCS04:** PC2 pin function selection  
00, 01: PC2/PTP0I  
10: PTP0  
11: AN2
- Bit 3~2     **PCS03~PCS02:** PC1 pin function selection  
00: PC1  
01: C0X  
10: VREF  
11: AN1
- Bit 1~0     **PCS01~PCS00:** PC0 pin function selection  
0x: PC0  
10: VREFI  
11: AN0

• **PCS1 Register**

| Bit  | 7     | 6     | 5     | 4     | 3     | 2     | 1     | 0     |
|------|-------|-------|-------|-------|-------|-------|-------|-------|
| Name | PCS17 | PCS16 | PCS15 | PCS14 | PCS13 | PCS12 | PCS11 | PCS10 |
| R/W  | R/W   | R/W   | R/W   | R/W   | R/W   | R/W   | R/W   | R/W   |
| POR  | 0     | 0     | 0     | 0     | 0     | 0     | 0     | 0     |

- Bit 7~6     **PCS17~PCS16:** PC7 pin function selection  
00, 01, 10: PC7/INT3/STCK0  
11: AN7
- Bit 5~4     **PCS15~PCS14:** PC6 pin function selection  
00, 01: PC6/STP0I  
10: STP0  
11: AN6
- Bit 3~2     **PCS13~PCS12:** PC5 pin function selection  
00, 01, 10: PC5/PTCK1  
11: AN5
- Bit 1~0     **PCS11~PCS10:** PC4 pin function selection  
00, 01: PC4/PTP1I  
10: PTP1  
11: AN4

• **PDS0 Register**

| Bit  | 7     | 6     | 5     | 4     | 3     | 2     | 1     | 0     |
|------|-------|-------|-------|-------|-------|-------|-------|-------|
| Name | PDS07 | PDS06 | PDS05 | PDS04 | PDS03 | PDS02 | PDS01 | PDS00 |
| R/W  | R/W   | R/W   | R/W   | R/W   | R/W   | R/W   | R/W   | R/W   |
| POR  | 0     | 0     | 0     | 0     | 0     | 0     | 0     | 0     |

- Bit 7~6     **PDS07~PDS06:** PD3 pin function selection  
00, 01, 10: PD3/PTCK2  
11: AN11
- Bit 5~4     **PDS05~PDS04:** PD2 pin function selection  
00: PD2/PTP2I  
01: PTP2  
10: TX1  
11: AN10
- Bit 3~2     **PDS03~PDS02:** PD1 pin function selection  
00, 01: PD1/STCK1  
10: RX1  
11: AN9
- Bit 1~0     **PDS01~PDS00:** PD0 pin function selection  
00, 01: PD0/INT2/STP1I  
10: STP1  
11: AN8

• **PDS1 Register**

| Bit  | 7 | 6 | 5     | 4     | 3     | 2     | 1     | 0     |
|------|---|---|-------|-------|-------|-------|-------|-------|
| Name | — | — | PDS15 | PDS14 | PDS13 | PDS12 | PDS11 | PDS10 |
| R/W  | — | — | R/W   | R/W   | R/W   | R/W   | R/W   | R/W   |
| POR  | — | — | 0     | 0     | 0     | 0     | 0     | 0     |

- Bit 7~6 Unimplemented, read as "0"
- Bit 5~4 **PDS15~PDS14**: PD6 pin function selection  
 00, 01: PD6/STP2I  
 10: STP2  
 11: C1X
- Bit 3~2 **PDS13~PDS12**: PD5 pin function selection  
 00, 01: PD5/PTCK3  
 10: TX0  
 11: C1+
- Bit 1~0 **PDS11~PDS10**: PD4 pin function selection  
 00: PD4/PTP3I  
 01: RX0  
 10: PTP3  
 11: C1-

• **PES0 Register**

| Bit  | 7     | 6     | 5     | 4     | 3     | 2     | 1     | 0     |
|------|-------|-------|-------|-------|-------|-------|-------|-------|
| Name | PES07 | PES06 | PES05 | PES04 | PES03 | PES02 | PES01 | PES00 |
| R/W  | R/W   | R/W   | R/W   | R/W   | R/W   | R/W   | R/W   | R/W   |
| POR  | 0     | 0     | 0     | 0     | 0     | 0     | 0     | 0     |

- Bit 7~6 **PES07~PES06**: PE3 pin function selection  
 00, 01: PE3/PTP1I  
 10: PTP1  
 11: SCKA
- Bit 5~4 **PES05~PES04**: PE2 pin function selection  
 00, 01, 10: PE2/PTCK1  
 11: SDIA
- Bit 3~2 **PES03~PES02**: PE1 pin function selection  
 00, 01: PE1/STP0I  
 10: STP0  
 11: SDOA
- Bit 1~0 **PES01~PES00**: PE0 pin function selection  
 00, 01, 10: PE0/STCK0  
 11:  $\overline{\text{SCSA}}$

• **PES1 Register**

| Bit  | 7 | 6 | 5 | 4 | 3 | 2 | 1     | 0     |
|------|---|---|---|---|---|---|-------|-------|
| Name | — | — | — | — | — | — | PES11 | PES10 |
| R/W  | — | — | — | — | — | — | R/W   | R/W   |
| POR  | — | — | — | — | — | — | 0     | 0     |

- Bit 7~2 Unimplemented, read as "0"
- Bit 1~0 **PES11~PES10**: PE4 pin function selection  
 00, 01, 10: PE4  
 11: VDDIO

• **PFS0 Register**

| Bit  | 7     | 6     | 5     | 4     | 3     | 2     | 1     | 0     |
|------|-------|-------|-------|-------|-------|-------|-------|-------|
| Name | PFS07 | PFS06 | PFS05 | PFS04 | PFS03 | PFS02 | PFS01 | PFS00 |
| R/W  | R/W   | R/W   | R/W   | R/W   | R/W   | R/W   | R/W   | R/W   |
| POR  | 0     | 0     | 0     | 0     | 0     | 0     | 0     | 0     |

- Bit 7~6     **PFS07~PFS06:** PF3 pin function selection  
00, 01: PF3  
10: SCK/SCL  
11: SCOM3
- Bit 5~4     **PFS05~PFS04:** PF2 pin function selection  
00, 01: PF2  
10: SDI/SDA  
11: SCOM2
- Bit 3~2     **PFS03~PFS02:** PF1 pin function selection  
00, 01: PF1  
10: SDO  
11: SCOM1
- Bit 1~0     **PFS01~PFS00:** PF0 pin function selection  
00, 01: PF0  
10: SCS  
11: SCOM0

• **PFS1 Register**

| Bit  | 7     | 6     | 5     | 4     | 3     | 2     | 1     | 0     |
|------|-------|-------|-------|-------|-------|-------|-------|-------|
| Name | PFS17 | PFS16 | PFS15 | PFS14 | PFS13 | PFS12 | PFS11 | PFS10 |
| R/W  | R/W   | R/W   | R/W   | R/W   | R/W   | R/W   | R/W   | R/W   |
| POR  | 0     | 0     | 0     | 0     | 0     | 0     | 0     | 0     |

- Bit 7~6     **PFS17~PFS16:** PF7 pin function selection  
00: PF7/STP2I  
01: TX1  
10: STP2  
11: C0+
- Bit 5~4     **PFS15~PFS14:** PF6 pin function selection  
00, 01: PF6/STCK2  
10: RX1  
11: C0-
- Bit 3~2     **PFS13~PFS12:** PF5 pin function selection  
00, 01: PF5/PTP0I  
10: PTP0  
11: XT1
- Bit 1~0     **PFS11~PFS10:** PF4 pin function selection  
00, 01, 10: PF4/PTCK0  
11: XT2

• **PGS0 Register – HT66F2360**

| Bit  | 7     | 6     | 5     | 4     | 3     | 2     | 1     | 0     |
|------|-------|-------|-------|-------|-------|-------|-------|-------|
| Name | PGS07 | PGS06 | PGS05 | PGS04 | PGS03 | PGS02 | PGS01 | PGS00 |
| R/W  | R/W   | R/W   | R/W   | R/W   | R/W   | R/W   | R/W   | R/W   |
| POR  | 0     | 0     | 0     | 0     | 0     | 0     | 0     | 0     |

- Bit 7~6     **PGS07~PGS06:** PG3 pin function selection  
00, 01, 10, 11: PG3
- Bit 5~4     **PGS05~PGS04:** PG2 pin function selection  
00, 01, 10, 11: PG2
- Bit 3~2     **PGS03~PGS02:** PG1 pin function selection  
00, 01, 10, 11: PG1
- Bit 1~0     **PGS01~PGS00:** PG0 pin function selection  
00, 01, 10, 11: PG0

• **PGS0 Register – HT66F2370/HT66F2390**

| Bit  | 7     | 6     | 5     | 4     | 3     | 2     | 1     | 0     |
|------|-------|-------|-------|-------|-------|-------|-------|-------|
| Name | PGS07 | PGS06 | PGS05 | PGS04 | PGS03 | PGS02 | PGS01 | PGS00 |
| R/W  | R/W   | R/W   | R/W   | R/W   | R/W   | R/W   | R/W   | R/W   |
| POR  | 0     | 0     | 0     | 0     | 0     | 0     | 0     | 0     |

- Bit 7~6     **PGS07~PGS06:** PG3 pin function selection  
00, 01, 10, 11: PG3
- Bit 5~4     **PGS05~PGS04:** PG2 pin function selection  
00, 01, 10, 11: PG2
- Bit 3~2     **PGS03~PGS02:** PG1 pin function selection  
00, 01, 10: PG1  
11: TX2
- Bit 1~0     **PGS01~PGS00:** PG0 pin function selection  
00, 01, 10: PG0  
11: RX2

• **PGS1 Register – HT66F2360/HT66F2370/HT66F2390**

| Bit  | 7     | 6     | 5     | 4     | 3     | 2     | 1     | 0     |
|------|-------|-------|-------|-------|-------|-------|-------|-------|
| Name | PGS17 | PGS16 | PGS15 | PGS14 | PGS13 | PGS12 | PGS11 | PGS10 |
| R/W  | R/W   | R/W   | R/W   | R/W   | R/W   | R/W   | R/W   | R/W   |
| POR  | 0     | 0     | 0     | 0     | 0     | 0     | 0     | 0     |

- Bit 7~6     **PGS17~PGS16:** PG7 pin function selection  
00, 01, 10, 11: PG7
- Bit 5~4     **PGS15~PGS14:** PG6 pin function selection  
00, 01, 10, 11: PG6
- Bit 3~2     **PGS13~PGS12:** PG5 pin function selection  
00, 01, 10, 11: PG5
- Bit 1~0     **PGS11~PGS10:** PG4 pin function selection  
00, 01, 10, 11: PG4

• **PHS0 Register – HT66F2360/HT66F2370/HT66F2390**

| Bit  | 7     | 6     | 5     | 4     | 3     | 2     | 1     | 0     |
|------|-------|-------|-------|-------|-------|-------|-------|-------|
| Name | PHS07 | PHS06 | PHS05 | PHS04 | PHS03 | PHS02 | PHS01 | PHS00 |
| R/W  | R/W   | R/W   | R/W   | R/W   | R/W   | R/W   | R/W   | R/W   |
| POR  | 0     | 0     | 0     | 0     | 0     | 0     | 0     | 0     |

- Bit 7~6 **PHS07~PHS06**: PH3 pin function selection  
00, 01, 10: PH3  
11: AN13
- Bit 5~4 **PHS05~PHS04**: PH2 pin function selection  
00, 01, 10: PH2  
11: AN12
- Bit 3~2 **PHS03~PHS02**: PH1 pin function selection  
00, 01, 10, 11: PH1
- Bit 1~0 **PHS01~PHS00**: PH0 pin function selection  
00, 01, 10, 11: PH0

• **PHS1 Register – HT66F2360/HT66F2370/HT66F2390**

| Bit  | 7 | 6 | 5 | 4 | 3     | 2     | 1     | 0     |
|------|---|---|---|---|-------|-------|-------|-------|
| Name | — | — | — | — | PHS13 | PHS12 | PHS11 | PHS10 |
| R/W  | — | — | — | — | R/W   | R/W   | R/W   | R/W   |
| POR  | — | — | — | — | 0     | 0     | 0     | 0     |

- Bit 7~4 Unimplemented, read as "0"
- Bit 3~2 **PHS13~PHS12**: PH5 pin function selection  
00, 01, 10: PH5  
11: AN15
- Bit 1~0 **PHS11~PHS10**: PH4 pin function selection  
00, 01, 10: PH4  
11: AN14

• **IFS0 Register**

| Bit  | 7 | 6       | 5       | 4       | 3       | 2       | 1       | 0       |
|------|---|---------|---------|---------|---------|---------|---------|---------|
| Name | — | PTCK3PS | PTCK2PS | PTCK1PS | PTCK0PS | STCK2PS | STCK1PS | STCK0PS |
| R/W  | — | R/W     | R/W     | R/W     | R/W     | R/W     | R/W     | R/W     |
| POR  | — | 0       | 0       | 0       | 0       | 0       | 0       | 0       |

- Bit 7 Unimplemented, read as "0"
- Bit 6 **PTCK3PS**: PTCK3 input source pin selection  
0: PD5  
1: PB1
- Bit 5 **PTCK2PS**: PTCK2 input source pin selection  
0: PD3  
1: PB2
- Bit 4 **PTCK1PS**: PTCK1 input source pin selection  
0: PC5  
1: PE2
- Bit 3 **PTCK0PS**: PTCK0 input source pin selection  
0: PC3  
1: PF4
- Bit 2 **STCK2PS**: STCK2 input source pin selection  
0: PF6  
1: PB0
- Bit 1 **STCK1PS**: STCK1 input source pin selection  
0: PD1  
1: PB7
- Bit 0 **STCK0PS**: STCK0 input source pin selection  
0: PC7  
1: PE0

• **IFS1 Register**

| Bit  | 7 | 6       | 5       | 4       | 3       | 2       | 1       | 0       |
|------|---|---------|---------|---------|---------|---------|---------|---------|
| Name | — | PTP3IPS | PTP2IPS | PTP1IPS | PTP0IPS | STP2IPS | STP1IPS | STP0IPS |
| R/W  | — | R/W     | R/W     | R/W     | R/W     | R/W     | R/W     | R/W     |
| POR  | — | 0       | 0       | 0       | 0       | 0       | 0       | 0       |

- Bit 7 Unimplemented, read as "0"
- Bit 6 **PTP3IPS**: PTP3I input source pin selection  
0: PD4  
1: PB2
- Bit 5 **PTP2IPS**: PTP2I input source pin selection  
0: PD2  
1: PB3
- Bit 4 **PTP1IPS**: PTP1I input source pin selection  
0: PC4  
1: PE3
- Bit 3 **PTP0IPS**: PTP0I input source pin selection  
0: PC2  
1: PF5
- Bit 2 **STP2IPS**: STP2I input source pin selection  
0: PD6  
1: PF7
- Bit 1 **STP1IPS**: STP1I input source pin selection  
0: PD0  
1: PB6
- Bit 0 **STP0IPS**: STP0I input source pin selection  
0: PC6  
1: PE1

• **IFS2 Register**

| Bit  | 7 | 6      | 5        | 4        | 3      | 2      | 1      | 0      |
|------|---|--------|----------|----------|--------|--------|--------|--------|
| Name | — | SCSBPS | SDISDAPS | SCKSCLPS | INT3PS | INT2PS | INT1PS | INT0PS |
| R/W  | — | R/W    | R/W      | R/W      | R/W    | R/W    | R/W    | R/W    |
| POR  | — | 0      | 0        | 0        | 0      | 0      | 0      | 0      |

- Bit 7 Unimplemented, read as "0"
- Bit 6 **SCSBPS**: SCS input source pin selection  
0: PA1  
1: PF0
- Bit 5 **SDISDAPS**: SDI/SDA input source pin selection  
0: PA4  
1: PF2
- Bit 4 **SCKSCLPS**: SCK/SCL input source pin selection  
0: PA5  
1: PF3
- Bit 3 **INT3PS**: INT3 input source pin selection  
0: PA5  
1: PC7
- Bit 2 **INT2PS**: INT2 input source pin selection  
0: PA4  
1: PD0
- Bit 1 **INT1PS**: INT1 input source pin selection  
0: PA3  
1: PA7
- Bit 0 **INT0PS**: INT0 input source pin selection  
0: PA1  
1: PA6

• **IFS3 Register – HT66F2350/HT66F2360**

| Bit  | 7 | 6 | 5 | 4 | 3 | 2 | 1     | 0     |
|------|---|---|---|---|---|---|-------|-------|
| Name | — | — | — | — | — | — | RX1PS | RX0PS |
| R/W  | — | — | — | — | — | — | R/W   | R/W   |
| POR  | — | — | — | — | — | — | 0     | 0     |

- Bit 7~2 Unimplemented, read as "0"
- Bit 1 **RX1PS**: RX1 input source pin selection  
 0: PD1  
 1: PF6
- Bit 0 **RX0PS**: RX0 input source pin selection  
 0: PA6  
 1: PD4

• **IFS3 Register – HT66F2370/HT66F2390**

| Bit  | 7 | 6 | 5 | 4 | 3 | 2     | 1     | 0     |
|------|---|---|---|---|---|-------|-------|-------|
| Name | — | — | — | — | — | RX2PS | RX1PS | RX0PS |
| R/W  | — | — | — | — | — | R/W   | R/W   | R/W   |
| POR  | — | — | — | — | — | 0     | 0     | 0     |

- Bit 7~3 Unimplemented, read as "0"
- Bit 2 **RX2PS**: RX2 input source pin selection  
 0: PB2  
 1: PG0
- Bit 1 **RX1PS**: RX1 input source pin selection  
 0: PD1  
 1: PF6
- Bit 0 **RX0PS**: RX0 input source pin selection  
 0: PA6  
 1: PD4

### I/O Pin Structures

The accompanying diagram illustrates the internal structures of the I/O logic function. As the exact logical construction of the I/O pin will differ from this drawing, it is supplied as a guide only to assist with the functional understanding of the logic function I/O pins. The wide range of pin-shared structures does not permit all types to be shown.

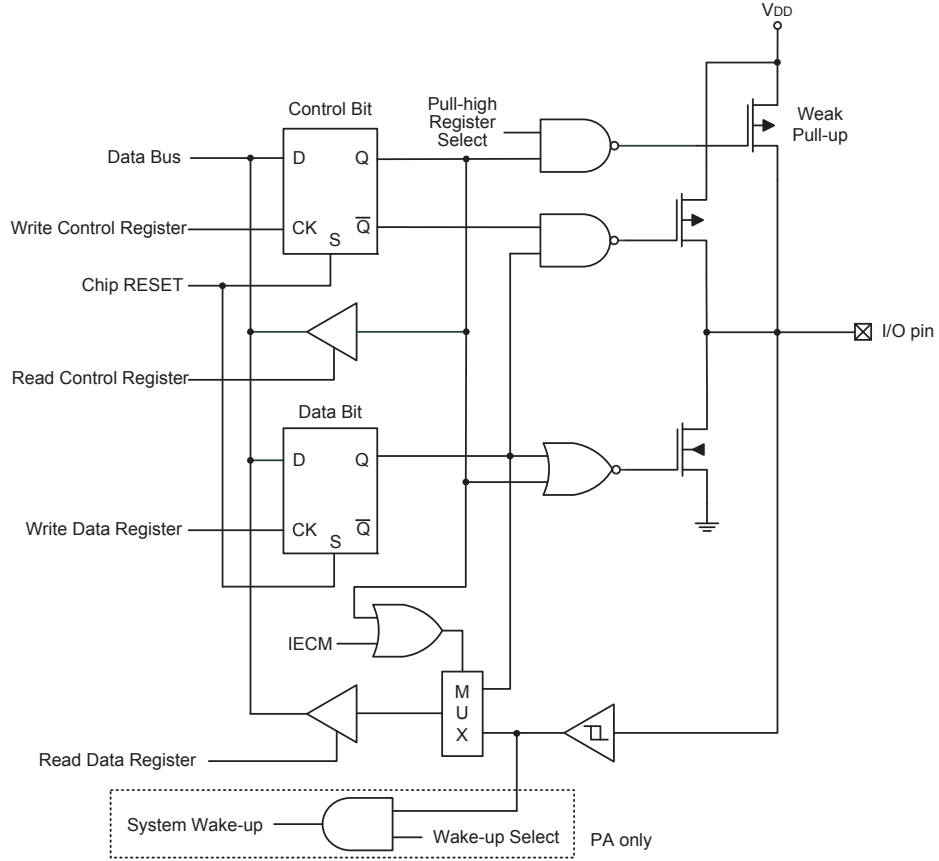

**Logic Function Input/Output Structure**

## Read Port Function

The READ PORT function is used to manage the reading of the output data from the data latch or I/O pin, which is specially designed for the IEC60730 self-diagnostic test on the I/O function and A/D paths. There is a register, IECC, which is used to control the READ PORT function. If the READ PORT function is disabled, the pin function will operate as the selected pin-shared function. When a specific data pattern, “11001010”, is written into the IECC register, the internal signal named IECM will be set high to enable the READ PORT function. If the READ PORT function is enabled, the value on the corresponding pins will be passed to the accumulator ACC when the read port instruction “mov acc, Px” is executed where the “x” stands for the corresponding I/O port name.

## IECC Register

| Bit  | 7     | 6     | 5     | 4     | 3     | 2     | 1     | 0     |
|------|-------|-------|-------|-------|-------|-------|-------|-------|
| Name | IECS7 | IECS6 | IECS5 | IECS4 | IECS3 | IECS2 | IECS1 | IECS0 |
| R/W  | R/W   | R/W   | R/W   | R/W   | R/W   | R/W   | R/W   | R/W   |
| POR  | 0     | 0     | 0     | 0     | 0     | 0     | 0     | 0     |

Bit 7~0 **IECS7~IECS0**: READ PORT function enable control bit 7~ bit 0  
 11001010: IECM=1 – READ PORT function is enabled  
 Others: IECM=0 – READ PORT function is disabled

| READ PORT Function  | Disabled  |                  | Enabled   |   |
|---|-----------|------------------|-----------|---|
| Port Control Register Bit – Px.C.n                        | 1         | 0                | 1         | 0 |
| I/O Function  | Pin value | Data latch value | Pin value |   |
| Digital Input Function                                    |           |                  |           |   |
| Digital Output Function (except I <sup>2</sup> C SDA/SCL) | 0         |                  |           |   |
| I <sup>2</sup> C SDA/SCL                                  | Pin value |                  |           |   |
| Analog Function   | 0         |                  |           |   |

Note: The value on the above table is the content of the ACC register after “mov a, Px” instruction is executed where “x” means the relevant port name.

The additional function of the READ PORT mode is to check the A/D path. When the READ PORT function is disabled, the A/D path from the external pin to the internal analog input will be switched off if the A/D input pin function is not selected by the corresponding selection bits. For the MCU with A/D converter channels, such as A/D AN15~AN0, the desired A/D channel can be switched on by properly configuring the external analog input channel selection bits in the A/D Control Register together with the corresponding analog input pin function is selected. However, the additional function of the READ PORT mode is to force the A/D path to be switched on. For example, when the AN0 is selected as the analog input channel as the READ PORT function is enabled, the AN0 analog input path will be switched on even if the AN0 analog input pin function is not selected. In this way, the AN0 analog input path can be examined by internally connecting the digital output on this shared pin with the AN0 analog input pin switch and then converting the corresponding digital data without any external analog input voltage connected.

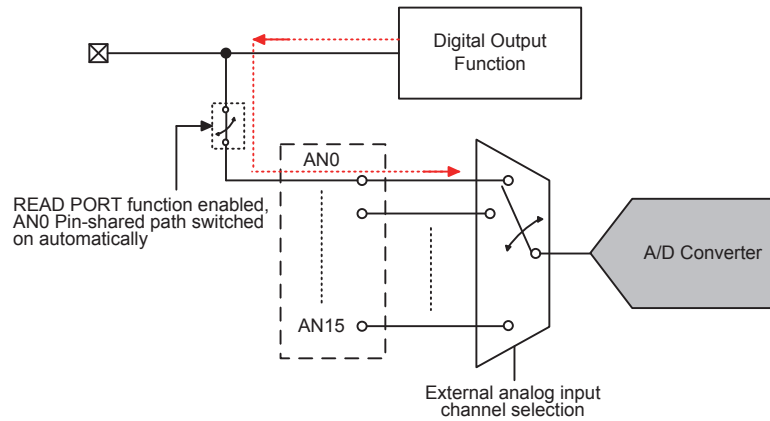

**A/D Channel Input Path Internally Connection**

### Programming Considerations

Within the user program, one of the things first to consider is port initialisation. After a reset, all of the I/O data and port control registers will be set to high. This means that all I/O pins will be defaulted to an input state, the level of which depends on the other connected circuitry and whether pull-high selections have been chosen. If the port control registers are then programmed to setup some pins as outputs, these output pins will have an initial high output value unless the associated port data registers are first programmed. Selecting which pins are inputs and which are outputs can be achieved byte-wide by loading the correct values into the appropriate port control register or by programming individual bits in the port control register using the "SET [m].i" and "CLR [m].i" instructions. Note that when using these bit control instructions, a read-modify-write operation takes place. The microcontroller must first read in the data on the entire port, modify it to the required new bit values and then rewrite this data back to the output ports.

Port A has the additional capability of providing wake-up functions. When the device is in the SLEEP or IDLE Mode, various methods are available to wake the device up. One of these is a high to low transition of any of the Port A pins. Single or multiple pins on Port A can be setup to have this function.

## Timer Modules – TM

One of the most fundamental functions in any microcontroller devices is the ability to control and measure time. To implement time related functions the device includes several Timer Modules, generally abbreviated to the name TM. The TMs are multi-purpose timing units and serve to provide operations such as Timer/Counter, Input Capture, Compare Match Output and Single Pulse Output as well as being the functional unit for the generation of PWM signals. Each of the TMs has two interrupts. The addition of input and output pins for each TM ensures that users are provided with timing units with a wide and flexible range of features.

The common features of the different TM types are described here with more detailed information provided in the individual Standard and Periodic TM sections.

### Introduction

These devices contain seven TMs and each individual TM can be categorised as a certain type, namely Standard Type TM or Periodic Type TM. Although similar in nature, the different TM types vary in their feature complexity. The common features to all of the Standard and Periodic TMs will be described in this section and the detailed operation regarding each of the TM types will be described in separate sections. The main features and differences between the two types of TMs are summarised in the accompanying table.

| TM Function                  | STM            | PTM            |
|------------------------------|----------------|----------------|
| Timer/Counter                | √              | √              |
| Input Capture                | √              | √              |
| Compare Match Output         | √              | √              |
| PWM Channels                 | 1              | 1              |
| Single Pulse Output          | 1              | 1              |
| PWM Alignment                | Edge           | Edge           |
| PWM Adjustment Period & Duty | Duty or Period | Duty or Period |

**TM Function Summary**

### TM Operation

The different types of TM offer a diverse range of functions, from simple timing operations to PWM signal generation. The key to understanding how the TM operates is to see it in terms of a free running count-up counter whose value is then compared with the value of pre-programmed internal comparators. When the free running count-up counter has the same value as the pre-programmed comparator, known as a compare match situation, a TM interrupt signal will be generated which can clear the counter and perhaps also change the condition of the TM output pin. The internal TM counter is driven by a user selectable clock source, which can be an internal clock or an external pin.

### TM Clock Source

The clock source which drives the main counter in each TM can originate from various sources. The selection of the required clock source is implemented using the xTnCK2~xTnCK0 bits in the xTMn control registers, where "x" stands for S or P type TM and "n" stands for the specific TM serial number. The clock source can be a ratio of the system clock,  $f_{SYS}$ , or the internal high clock,  $f_H$ , the  $f_{SUB}$  clock source or the external xTCKn pin. The xTCKn pin clock source is used to allow an external signal to drive the TM as an external clock source for event counting.

### TM Interrupts

The Standard or Periodic type TM has two internal interrupt, one for each of the internal comparator A or comparator P, which generate a TM interrupt when a compare match condition occurs. When a TM interrupt is generated, it can be used to clear the counter and also to change the state of the TM output pin.

### TM External Pins

Each of the TMs, irrespective of what type, has two TM input pins, with the label xTCKn and xTPnI respectively. The xTMn input pin, xTCKn, is essentially a clock source for the xTMn and is selected using the xTnCK2~xTnCK0 bits in the xTMnC0 register. This external TM input pin allows an external clock source to drive the internal TM. The xTCKn input pin can be chosen to have either a rising or falling active edge. The STCKn and PTCKn pins are also used as the external trigger input pin in single pulse output mode for the STMn and PTMn respectively.

The other xTM input pin, STPnI or PTPnI, is the capture input whose active edge can be a rising edge, a falling edge or both rising and falling edges and the active edge transition type is selected using the STnIO1~STnIO0 or PTnIO1~PTnIO0 bits in the STMnC1 or PTMnC1 register respectively. There is another capture input, PTCKn, for PTMn capture input mode, which can be used as the external trigger input source except the PTPnI pin.

The TMs each have one output pin, xTPn. The TM output pin can be selected using the corresponding pin-shared function selection bits described in the Pin-shared Function section. When the TM is in the Compare Match Output Mode, these pins can be controlled by the TM to switch to a high or low level or to toggle when a compare match situation occurs. The external xTPn output pin is also the pin where the TM generates the PWM output waveform. As the TM output pins are pin-shared with other functions, the TM output function must first be setup using relevant pin-shared function selection register.

| Device    | STM          |        | PTM          |        |
|-----------|--------------|--------|--------------|--------|
|           | Input        | Output | Input        | Output |
| HT66F2350 | STCK0, STP0I | STP0   | PTCK0, PTP0I | PTP0   |
| HT66F2360 |              |        | PTCK1, PTP1I | PTP1   |
| HT66F2370 | STCK1, STP1I | STP1   | PTCK2, PTP2I | PTP2   |
| HT66F2390 |              |        | PTCK3, PTP3I | PTP3   |

**TM External Pins**

## TM Input/Output Pin Selection

Selecting to have a TM input/output or whether to retain its other shared function is implemented using the relevant pin-shared function selection registers, with the corresponding selection bits in each pin-shared function register corresponding to a TM input/output pin. Configuring the selection bits correctly will setup the corresponding pin as a TM input/output. The details of the pin-shared function selection are described in the pin-shared function section.

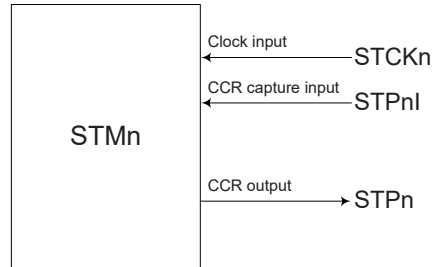

STM Function Pin Control Block Diagram (n=0 ~ 2)

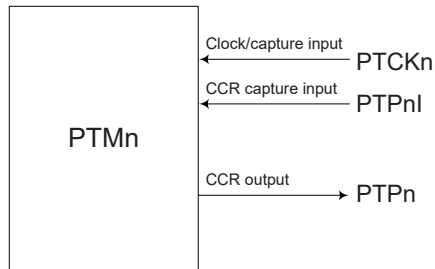

PTM Function Pin Control Block Diagram (n=0 ~ 3)

## Programming Considerations

The TM Counter Registers and the Capture/Compare CCRA and CCRP registers, all have a low and high byte structure. The high bytes can be directly accessed, but as the low bytes can only be accessed via an internal 8-bit buffer, reading or writing to these register pairs must be carried out in a specific way. The important point to note is that data transfer to and from the 8-bit buffer and its related low byte only takes place when a write or read operation to its corresponding high byte is executed.

As the CCRA and CCRP registers are implemented in the way shown in the following diagram and accessing these register pairs is carried out in a specific way as described above, it is recommended to use the "MOV" instruction to access the CCRA and CCRP low byte registers, named xTMnAL and PTMnRPL, using the following access procedures. Accessing the CCRA or CCRB low byte registers without following these access procedures will result in unpredictable values.

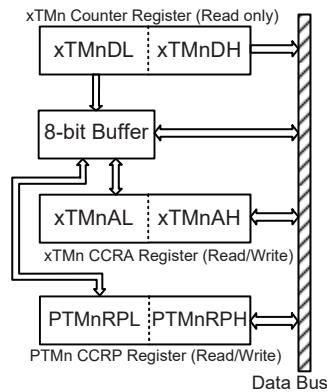

The following steps show the read and write procedures:

- Writing Data to CCRA or CCRP
  - ♦ Step 1. Write data to Low Byte xTMnAL or PTMnRPL
    - note that here data is only written to the 8-bit buffer.
  - ♦ Step 2. Write data to High Byte xTMnAH or PTMnRPH
    - here data is written directly to the high byte registers and simultaneously data is latched from the 8-bit buffer to the Low Byte registers.
- Reading Data from the Counter Registers and CCRA or CCRP
  - ♦ Step 1. Read data from the High Byte xTMnDH, xTMnAH or PTMnRPH
    - here data is read directly from the High Byte registers and simultaneously data is latched from the Low Byte register into the 8-bit buffer.
  - ♦ Step 2. Read data from the Low Byte xTMnDL, xTMnAL or PTMnRPL
    - this step reads data from the 8-bit buffer.

## Standard Type TM – STM

The Standard Type TM contains five operating modes, which are Compare Match Output, Timer/Event Counter, Capture Input, Single Pulse Output and PWM Output modes. The Standard TM can also be controlled with two external input pins and can drive one external output pin.

| Device   | STM Core                         | STM Input Pin                                | STM Output Pin       |
|--|----------------------------------|--|----------------------|
| HT66F2350<br>HT66F2360<br>HT66F2370<br>HT66F2390 | 16-bit STM<br>(STM0, STM1, STM2) | STCK0, STP0I<br>STCK1, STP1I<br>STCK2, STP2I | STP0<br>STP1<br>STP2 |

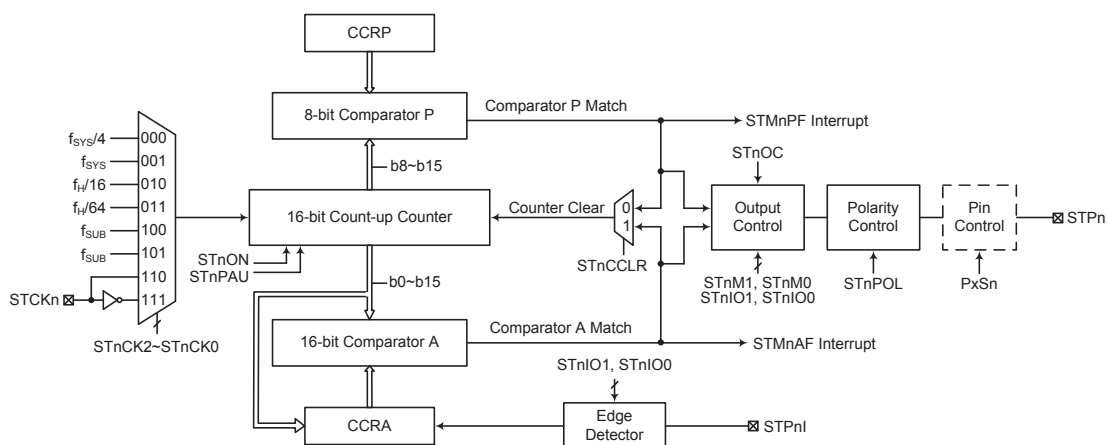

**Standard Type TM Block Diagram (n=0 ~ 2)**

### Standard TM Operation

The size of Standard TM is 16-bit wide and its core is a 16-bit count-up counter which is driven by a user selectable internal or external clock source. There are also two internal comparators with the names, Comparator A and Comparator P. These comparators will compare the value in the counter with CCRP and CCRA registers. The CCRP comparator is 8-bit wide whose value is compared the with highest 8 bits in the counter while the CCRA is the sixteen bits and therefore compares all counter bits.

The only way of changing the value of the 16-bit counter using the application program, is to clear the counter by changing the STnON bit from low to high. The counter will also be cleared automatically by a counter overflow or a compare match with one of its associated comparators. When these conditions occur, a STM interrupt signal will also usually be generated. The Standard Type TM can operate in a number of different operational modes, can be driven by different clock sources including an input pin and can also control an output pin. All operating setup conditions are selected using relevant internal registers.

### Standard Type TM Register Description

Overall operation of the Standard TM is controlled using a series of registers. A read only register pair exists to store the internal counter 16-bit value, while a read/write register pair exists to store the internal 16-bit CCRA value. The STMnRP register is used to store the 8-bit CCRP value. The remaining two registers are control registers which setup the different operating and control modes.

| Register Name | Bit    |        |        |        |        |        |        |         |
|---------------|--------|--------|--------|--------|--------|--------|--------|---------|
|               | 7      | 6      | 5      | 4      | 3      | 2      | 1      | 0       |
| STMnC0        | STnPAU | STnCK2 | STnCK1 | STnCK0 | STnON  | —      | —      | —       |
| STMnC1        | STnM1  | STnM0  | STnIO1 | STnIO0 | STnOC  | STnPOL | STnDPX | STnCCLR |
| STMnDL        | D7     | D6     | D5     | D4     | D3     | D2     | D1     | D0      |
| STMnDH        | D15    | D14    | D13    | D12    | D11    | D10    | D9     | D8      |
| STMnAL        | D7     | D6     | D5     | D4     | D3     | D2     | D1     | D0      |
| STMnAH        | D15    | D14    | D13    | D12    | D11    | D10    | D9     | D8      |
| STMnRP        | STnRP7 | STnRP6 | STnRP5 | STnRP4 | STnRP3 | STnRP2 | STnRP1 | STnRP0  |

**16-bit Standard TM Registers List (n=0 ~ 2)**

- **STMnDL Register**

| Bit  | 7  | 6  | 5  | 4  | 3  | 2  | 1  | 0  |
|------|----|----|----|----|----|----|----|----|
| Name | D7 | D6 | D5 | D4 | D3 | D2 | D1 | D0 |
| R/W  | R  | R  | R  | R  | R  | R  | R  | R  |
| POR  | 0  | 0  | 0  | 0  | 0  | 0  | 0  | 0  |

Bit 7~0      STMn Counter Low Byte Register bit 7 ~ bit 0  
 STMn 16-bit Counter bit 7 ~ bit 0

- **STMnDH Register**

| Bit  | 7   | 6   | 5   | 4   | 3   | 2   | 1  | 0  |
|------|-----|-----|-----|-----|-----|-----|----|----|
| Name | D15 | D14 | D13 | D12 | D11 | D10 | D9 | D8 |
| R/W  | R   | R   | R   | R   | R   | R   | R  | R  |
| POR  | 0   | 0   | 0   | 0   | 0   | 0   | 0  | 0  |

Bit 7~0      STMn Counter High Byte Register bit 7 ~ bit 0  
 STMn 16-bit Counter bit 15 ~ bit 8

- **STMnAL Register**

| Bit  | 7   | 6   | 5   | 4   | 3   | 2   | 1   | 0   |
|------|-----|-----|-----|-----|-----|-----|-----|-----|
| Name | D7  | D6  | D5  | D4  | D3  | D2  | D1  | D0  |
| R/W  | R/W | R/W | R/W | R/W | R/W | R/W | R/W | R/W |
| POR  | 0   | 0   | 0   | 0   | 0   | 0   | 0   | 0   |

Bit 7~0      STMn CCRA Low Byte Register bit 7 ~ bit 0  
 STMn 16-bit CCRA bit 7 ~ bit 0

- **STMnAH Register**

| Bit  | 7   | 6   | 5   | 4   | 3   | 2   | 1   | 0   |
|------|-----|-----|-----|-----|-----|-----|-----|-----|
| Name | D15 | D14 | D13 | D12 | D11 | D10 | D9  | D8  |
| R/W  | R/W | R/W | R/W | R/W | R/W | R/W | R/W | R/W |
| POR  | 0   | 0   | 0   | 0   | 0   | 0   | 0   | 0   |

Bit 7~0      STMn CCRA High Byte Register bit 7 ~ bit 0  
 STMn 16-bit CCRA bit 15 ~ bit 8

• **STMnC0 Register**

| Bit  | 7      | 6      | 5      | 4      | 3     | 2 | 1 | 0 |
|------|--------|--------|--------|--------|-------|---|---|---|
| Name | STnPAU | STnCK2 | STnCK1 | STnCK0 | STnON | — | — | — |
| R/W  | R/W    | R/W    | R/W    | R/W    | R/W   | — | — | — |
| POR  | 0      | 0      | 0      | 0      | 0     | — | — | — |

Bit 7 **STnPAU**: STMn Counter Pause control

0: Run  
1: Pause

The counter can be paused by setting this bit high. Clearing the bit to zero restores normal counter operation. When in a Pause condition the STMn will remain powered up and continue to consume power. The counter will retain its residual value when this bit changes from low to high and resume counting from this value when the bit changes to a low value again.

Bit 6~4 **STnCK2~STnCK0**: Select STMn Counter clock

000:  $f_{SYS}/4$   
 001:  $f_{SYS}$   
 010:  $f_H/16$   
 011:  $f_H/64$   
 100:  $f_{SUB}$   
 101:  $f_{SUB}$   
 110: STCKn rising edge clock  
 111: STCKn falling edge clock

These three bits are used to select the clock source for the STMn. The external pin clock source can be chosen to be active on the rising or falling edge. The clock source  $f_{SYS}$  is the system clock, while  $f_H$  and  $f_{SUB}$  are other internal clocks, the details of which can be found in the oscillator section.

Bit 3 **STnON**: STMn Counter On/Off control

0: Off  
1: On

This bit controls the overall on/off function of the STMn. Setting the bit high enables the counter to run while clearing the bit disables the STMn. Clearing this bit to zero will stop the counter from counting and turn off the STMn which will reduce its power consumption. When the bit changes state from low to high the internal counter value will be reset to zero, however when the bit changes from high to low, the internal counter will retain its residual value until the bit returns high again. If the STMn is in the Compare Match Output Mode then the STMn output pin will be reset to its initial condition, as specified by the STnOC bit, when the STnON bit changes from low to high.

Bit 2~0 Unimplemented, read as "0"

• **STMnC1 Register**

| Bit  | 7     | 6     | 5      | 4      | 3     | 2      | 1      | 0       |
|------|-------|-------|--------|--------|-------|--------|--------|---------|
| Name | STnM1 | STnM0 | STnIO1 | STnIO0 | STnOC | STnPOL | STnDPX | STnCCLR |
| R/W  | R/W   | R/W   | R/W    | R/W    | R/W   | R/W    | R/W    | R/W     |
| POR  | 0     | 0     | 0      | 0      | 0     | 0      | 0      | 0       |

Bit 7~6 **STnM1~STnM0**: Select STMn Operating Mode

- 00: Compare Match Output Mode
- 01: Capture Input Mode
- 10: PWM Mode or Single Pulse Output Mode
- 11: Timer/Counter Mode

These bits setup the required operating mode for the STMn. To ensure reliable operation the STMn should be switched off before any changes are made to the STnM1 and STnM0 bits. In the Timer/Counter Mode, the STMn output pin control will be disabled.

Bit 5~4 **STnIO1~STnIO0**: Select STMn external pin STPn function

Compare Match Output Mode

- 00: No change
- 01: Output low
- 10: Output high
- 11: Toggle output

PWM Output Mode/Single Pulse Output Mode

- 00: PWM output inactive state
- 01: PWM output active state
- 10: PWM output
- 11: Single Pulse Output

Capture Input Mode

- 00: Input capture at rising edge of STPnI
- 01: Input capture at falling edge of STPnI
- 10: Input capture at rising/falling edge of STPnI
- 11: Input capture disabled

Timer/Counter Mode

Unused

These two bits are used to determine how the STMn output pin changes state when a certain condition is reached. The function that these bits select depends upon in which mode the STMn is running.

In the Compare Match Output Mode, the STnIO1 and STnIO0 bits determine how the STMn output pin changes state when a compare match occurs from the Comparator A. The TM output pin can be setup to switch high, switch low or to toggle its present state when a compare match occurs from the Comparator A. When the bits are both zero, then no change will take place on the output. The initial value of the STMn output pin should be setup using the STnOC bit in the STMnC1 register. Note that the output level requested by the STnIO1 and STnIO0 bits must be different from the initial value setup using the STnOC bit otherwise no change will occur on the STMn output pin when a compare match occurs. After the STMn output pin changes state, it can be reset to its initial level by changing the level of the STnON bit from low to high.

In the PWM Output Mode, the STnIO1 and STnIO0 bits determine how the STMn output pin changes state when a certain compare match condition occurs. The PWM output function is modified by changing these two bits. It is necessary to only change the values of the STnIO1 and STnIO0 bits only after the STMn has been switched off. Unpredictable PWM outputs will occur if the STnIO1 and STnIO0 bits are changed when the STMn is running.

- Bit 3**      **STnOC:** STMn STPn Output control  
 Compare Match Output Mode  
     0: Initial low  
     1: Initial high  
 PWM Output Mode/Single Pulse Output Mode  
     0: Active low  
     1: Active high  
 This is the output control bit for the STMn output pin. Its operation depends upon whether STMn is being used in the Compare Match Output Mode or in the PWM Mode/Single Pulse Output Mode. It has no effect if the STMn is in the Timer/Counter Mode. In the Compare Match Output Mode it determines the logic level of the STMn output pin before a compare match occurs. In the PWM Output Mode/Single Pulse Output Mode it determines if the PWM signal is active high or active low.
- Bit 2**      **STnPOL:** STMn STPn Output polarity control  
     0: Non-inverted  
     1: Inverted  
 This bit controls the polarity of the STPn output pin. When the bit is set high the STMn output pin will be inverted and not inverted when the bit is zero. It has no effect if the STMn is in the Timer/Counter Mode.
- Bit 1**      **STnDPX:** STMn PWM duty/period control  
     0: CCRP – period; CCRA – duty  
     1: CCRP – duty; CCRA – period  
 This bit determines which of the CCRA and CCRP registers are used for period and duty control of the PWM waveform.
- Bit 0**      **STnCCLR:** STMn Counter Clear condition selection  
     0: Comparator P match  
     1: Comparator A match  
 This bit is used to select the method which clears the counter. Remember that the Standard TM contains two comparators, Comparator A and Comparator P, either of which can be selected to clear the internal counter. With the STnCCLR bit set high, the counter will be cleared when a compare match occurs from the Comparator A. When the bit is low, the counter will be cleared when a compare match occurs from the Comparator P or with a counter overflow. A counter overflow clearing method can only be implemented if the CCRP bits are all cleared to zero. The STnCCLR bit is not used in the PWM Output, Single Pulse Output or Capture Input Mode.

• **STMnRP Register**

| Bit  | 7      | 6      | 5      | 4      | 3      | 2      | 1      | 0      |
|------|--------|--------|--------|--------|--------|--------|--------|--------|
| Name | STnRP7 | STnRP6 | STnRP5 | STnRP4 | STnRP3 | STnRP2 | STnRP1 | STnRP0 |
| R/W  | R/W    | R/W    | R/W    | R/W    | R/W    | R/W    | R/W    | R/W    |
| POR  | 0      | 0      | 0      | 0      | 0      | 0      | 0      | 0      |

- Bit 7~0**      **STnRP7~STnRP0:** STMn CCRP 8-bit register, compared with the STMn counter bit 15~bit 8  
 Comparator P match period =  
     0: 65536 STMn clocks  
     1~255: (1~255) × 256 STMn clocks  
 These eight bits are used to setup the value on the internal CCRP 8-bit register, which are then compared with the internal counter's highest eight bits. The result of this comparison can be selected to clear the internal counter if the STnCCLR bit is set to zero. Setting the STnCCLR bit to zero ensures that a compare match with the CCRP values will reset the internal counter. As the CCRP bits are only compared with the highest eight counter bits, the compare values exist in 256 clock cycle multiples. Clearing all eight bits to zero is in effect allowing the counter to overflow at its maximum value.

## Standard Type TM Operation Modes

The Standard Type TM can operate in one of five operating modes, Compare Match Output Mode, PWM Output Mode, Single Pulse Output Mode, Capture Input Mode or Timer/Counter Mode. The operating mode is selected using the STnM1 and STnM0 bits in the STMnC1 register.

### Compare Match Output Mode

To select this mode, bits STnM1 and STnM0 in the STMnC1 register, should be set to 00 respectively. In this mode once the counter is enabled and running it can be cleared by three methods. These are a counter overflow, a compare match from Comparator A and a compare match from Comparator P. When the STnCCLR bit is low, there are two ways in which the counter can be cleared. One is when a compare match from Comparator P, the other is when the CCRP bits are all zero which allows the counter to overflow. Here both STMnAF and STMnPF interrupt request flags for Comparator A and Comparator P respectively, will both be generated.

If the STnCCLR bit in the STMnC1 register is high then the counter will be cleared when a compare match occurs from Comparator A. However, here only the STMnAF interrupt request flag will be generated even if the value of the CCRP bits is less than that of the CCRA registers. Therefore when STnCCLR is high no STMnPF interrupt request flag will be generated. In the Compare Match Output Mode, the CCRA can not be set to "0".

As the name of the mode suggests, after a comparison is made, the STMn output pin, will change state. The STMn output pin condition however only changes state when a STMnAF interrupt request flag is generated after a compare match occurs from Comparator A. The STMnPF interrupt request flag, generated from a compare match occurs from Comparator P, will have no effect on the STMn output pin. The way in which the STMn output pin changes state are determined by the condition of the STnIO1 and STnIO0 bits in the STMnC1 register. The STMn output pin can be selected using the STnIO1 and STnIO0 bits to go high, to go low or to toggle from its present condition when a compare match occurs from Comparator A. The initial condition of the STMn output pin, which is setup after the STnON bit changes from low to high, is setup using the STnOC bit. Note that if the STnIO1 and STnIO0 bits are zero then no pin change will take place.

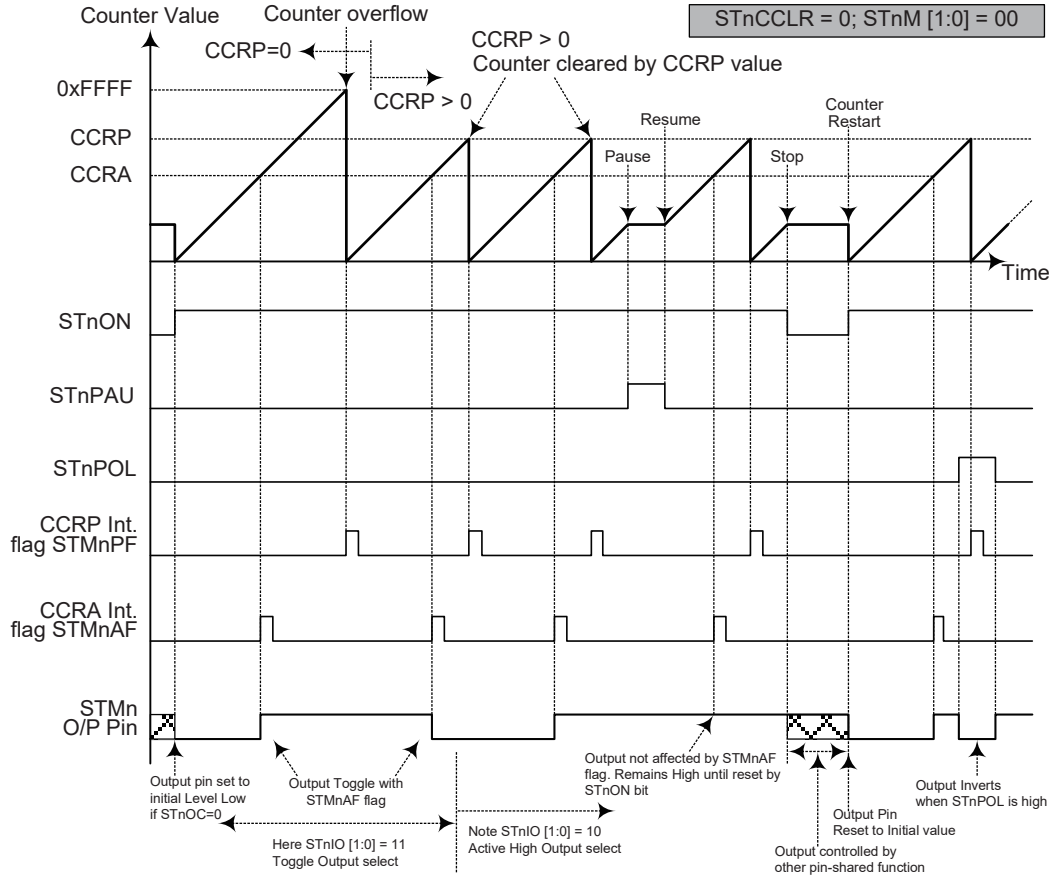

**Compare Match Output Mode –  $STnCCR=0$**

- Note: 1. With  $STnCCR=0$  a Comparator P match will clear the counter  
 2. The  $STMn$  output pin is controlled only by the  $STMnAF$  flag  
 3. The output pin is reset to its initial state by a  $STMnON$  bit rising edge  
 4.  $n=0 \sim 2$

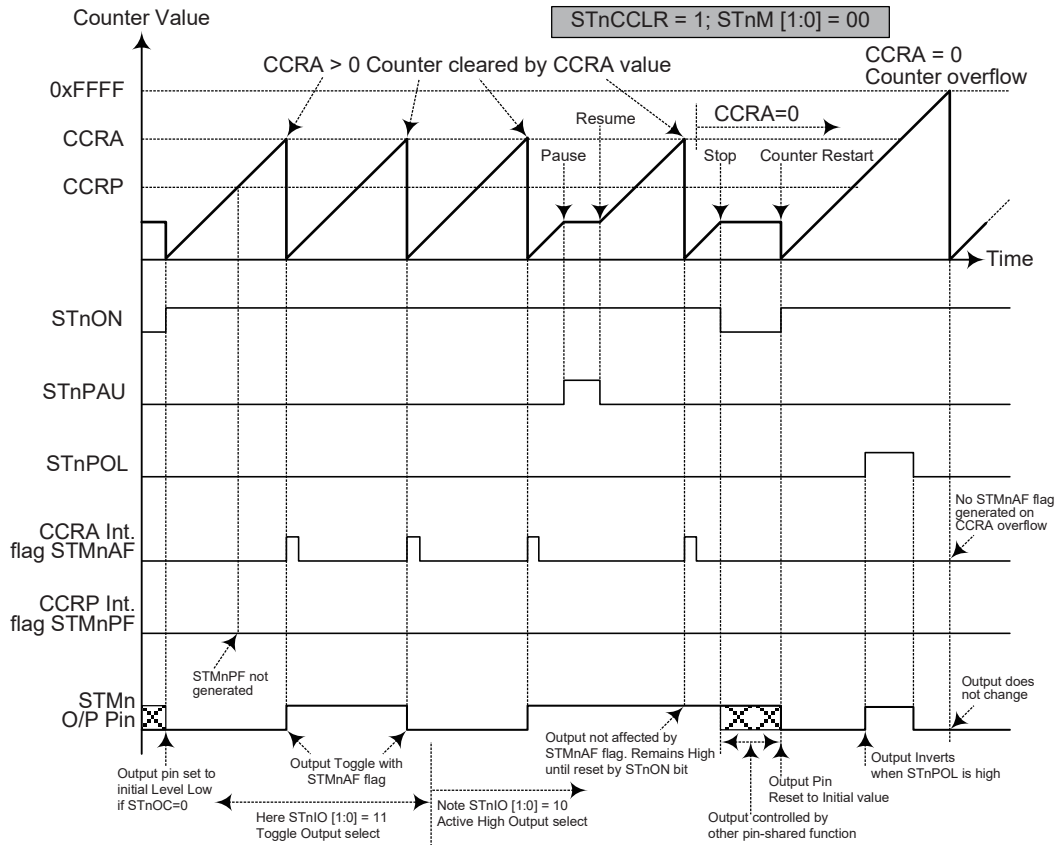

**Compare Match Output Mode –STnCCLR=1**

- Note: 1. With STnCCLR=1 a Comparator A match will clear the counter  
 2. The STMn output pin is controlled only by the STMnAF flag  
 3. The output pin is reset to its initial state by a STnON bit rising edge  
 4. A STMnPF flag is not generated when STnCCLR=1  
 5. n=0 ~ 2

### Timer/Counter Mode

To select this mode, bits STnM1 and STnM0 in the STMnC1 register should be set to 11 respectively. The Timer/Counter Mode operates in an identical way to the Compare Match Output Mode generating the same interrupt flags. The exception is that in the Timer/Counter Mode the STMn output pin is not used. Therefore the above description and Timing Diagrams for the Compare Match Output Mode can be used to understand its function. As the STMn output pin is not used in this mode, the pin can be used as a normal I/O pin or other pin-shared function.

### PWM Output Mode

To select this mode, bits STnM1 and STnM0 in the STMnC1 register should be set to 10 respectively and also the STnIO1 and STnIO0 bits should be set to 10 respectively. The PWM function within the STMn is useful for applications which require functions such as motor control, heating control, illumination control etc. By providing a signal of fixed frequency but of varying duty cycle on the STMn output pin, a square wave AC waveform can be generated with varying equivalent DC RMS values.

As both the period and duty cycle of the PWM waveform can be controlled, the choice of generated waveform is extremely flexible. In the PWM mode, the STnCCLR bit has no effect as the PWM period. Both of the CCRA and CCRP registers are used to generate the PWM waveform, one register is used to clear the internal counter and thus control the PWM waveform frequency, while the other one is used to control the duty cycle. Which register is used to control either frequency or duty cycle is determined using the STnDPX bit in the STMnC1 register. The PWM waveform frequency and duty cycle can therefore be controlled by the values in the CCRA and CCRP registers.

An interrupt flag, one for each of the CCRA and CCRP, will be generated when a compare match occurs from either Comparator A or Comparator P. The STnOC bit in the STMnC1 register is used to select the required polarity of the PWM waveform while the two STnIO1 and STnIO0 bits are used to enable the PWM output or to force the STMn output pin to a fixed high or low level. The STnPOL bit is used to reverse the polarity of the PWM output waveform.

- **16-bit STMn, PWM Output Mode, Edge-aligned Mode, STnDPX=0**

| CCRP   | 1~255    | 0     |
|--------|----------|-------|
| Period | CCRP×256 | 65536 |
| Duty   | CCRA     |       |

If  $f_{SYS}=16\text{MHz}$ , STMn clock source is  $f_{SYS}/4$ , CCRP=2 and CCRA=128,

The STMn PWM output frequency= $(f_{SYS}/4)/(2\times 256)=f_{SYS}/2048=8\text{ kHz}$ , duty= $128/(2\times 256)=25\%$ .

If the Duty value defined by the CCRA register is equal to or greater than the Period value, then the PWM output duty is 100%.

- **16-bit STMn, PWM Output Mode, Edge-aligned Mode, STnDPX=1**

| CCRP   | 1~255    | 0     |
|--------|----------|-------|
| Period | CCRA     |       |
| Duty   | CCRP×256 | 65536 |

The PWM output period is determined by the CCRA register value together with the TM clock while the PWM duty cycle is defined by the CCRP register value except when the CCRP value is equal to 0.





**Single Pulse Output Mode**

To select this mode, bits STnM1 and STnM0 in the STMnC1 register should be set to 10 respectively and also the STnIO1 and STnIO0 bits should be set to 11 respectively. The Single Pulse Output Mode, as the name suggests, will generate a single shot pulse on the STMn output pin.

The trigger for the pulse output leading edge is a low to high transition of the STnON bit, which can be implemented using the application program. However in the Single Pulse Mode, the STnON bit can also be made to automatically change from low to high using the external STCKn pin, which will in turn initiate the Single Pulse output. When the STnON bit transitions to a high level, the counter will start running and the pulse leading edge will be generated. The STnON bit should remain high when the pulse is in its active state. The generated pulse trailing edge will be generated when the STnON bit is cleared to zero, which can be implemented using the application program or when a compare match occurs from Comparator A.

However a compare match from Comparator A will also automatically clear the STnON bit and thus generate the Single Pulse output trailing edge. In this way the CCRA value can be used to control the pulse width. A compare match from Comparator A will also generate a STMn interrupt. The counter can only be reset back to zero when the STnON bit changes from low to high when the counter restarts. In the Single Pulse Mode CCRP is not used. The STnCLR and STnDPX bits are not used in this Mode.

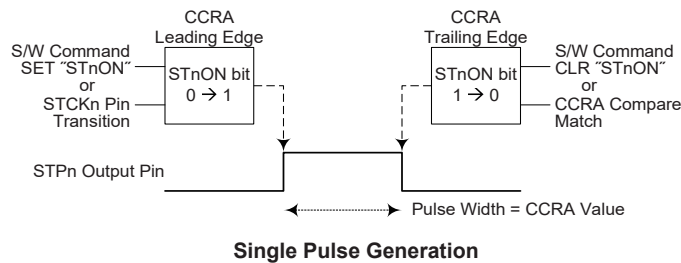

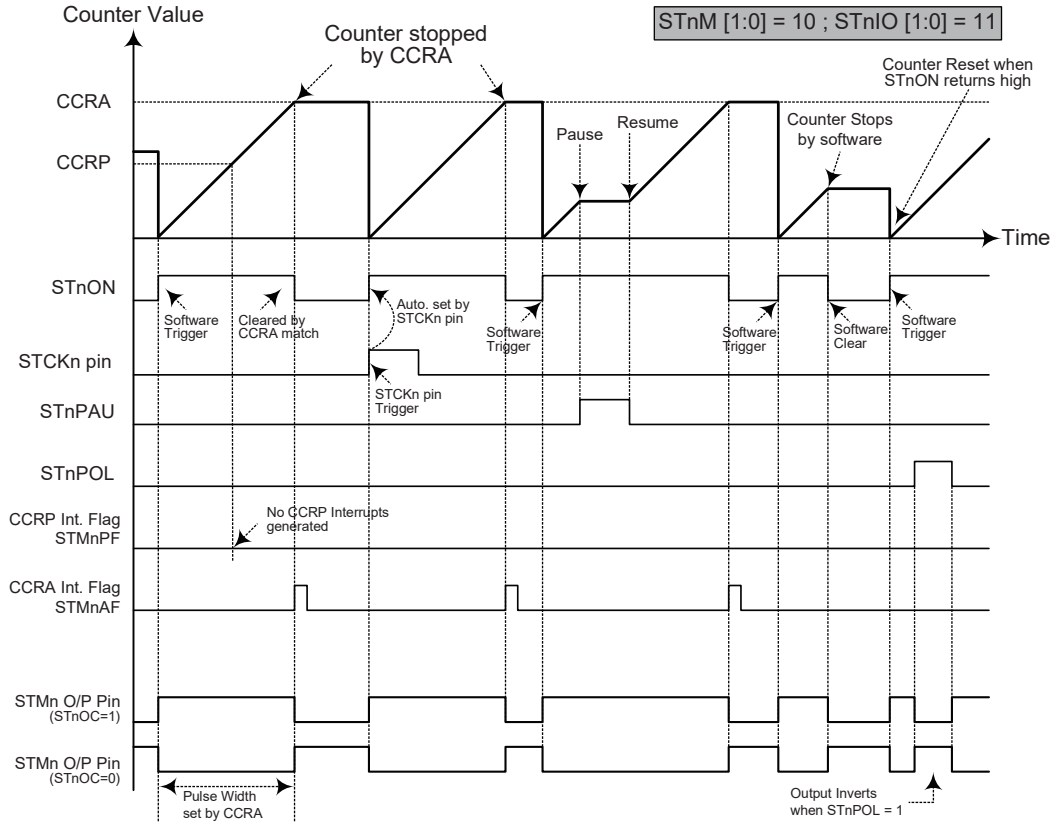

**Single Pulse Output Mode**

- Note: 1. Counter stopped by CCRA  
 2. CCRP is not used  
 3. The pulse triggered by the STCKn pin or by setting the STnON bit high  
 4. A STCKn pin active edge will automatically set the STnON bit high.  
 5. In the Single Pulse Mode, STnIO [1:0] must be set to "11" and can not be changed.  
 6. n=0 ~ 2

### **Capture Input Mode**

To select this mode bits STnM1 and STnM0 in the STMnC1 register should be set to 01 respectively. This mode enables external signals to capture and store the present value of the internal counter and can therefore be used for applications such as pulse width measurements. The external signal is supplied on the STPnI pin, whose active edge can be a rising edge, a falling edge or both rising and falling edges; the active edge transition type is selected using the STnIO1 and STnIO0 bits in the STMnC1 register. The counter is started when the STnON bit changes from low to high which is initiated using the application program.

When the required edge transition appears on the STPnI pin the present value in the counter will be latched into the CCRA registers and a STMn interrupt generated. Irrespective of what events occur on the STPnI pin the counter will continue to free run until the STnON bit changes from high to low. When a CCRP compare match occurs the counter will reset back to zero; in this way the CCRP value can be used to control the maximum counter value. When a CCRP compare match occurs from Comparator P, a STMn interrupt will also be generated. Counting the number of overflow interrupt signals from the CCRP can be a useful method in measuring long pulse widths. The STnIO1 and STnIO0 bits can select the active trigger edge on the STPnI pin to be a rising edge, falling edge or both edge types. If the STnIO1 and STnIO0 bits are both set high, then no capture operation will take place irrespective of what happens on the STPnI pin, however it must be noted that the counter will continue to run. The STnCCLR and STnDPX bits are not used in this Mode.

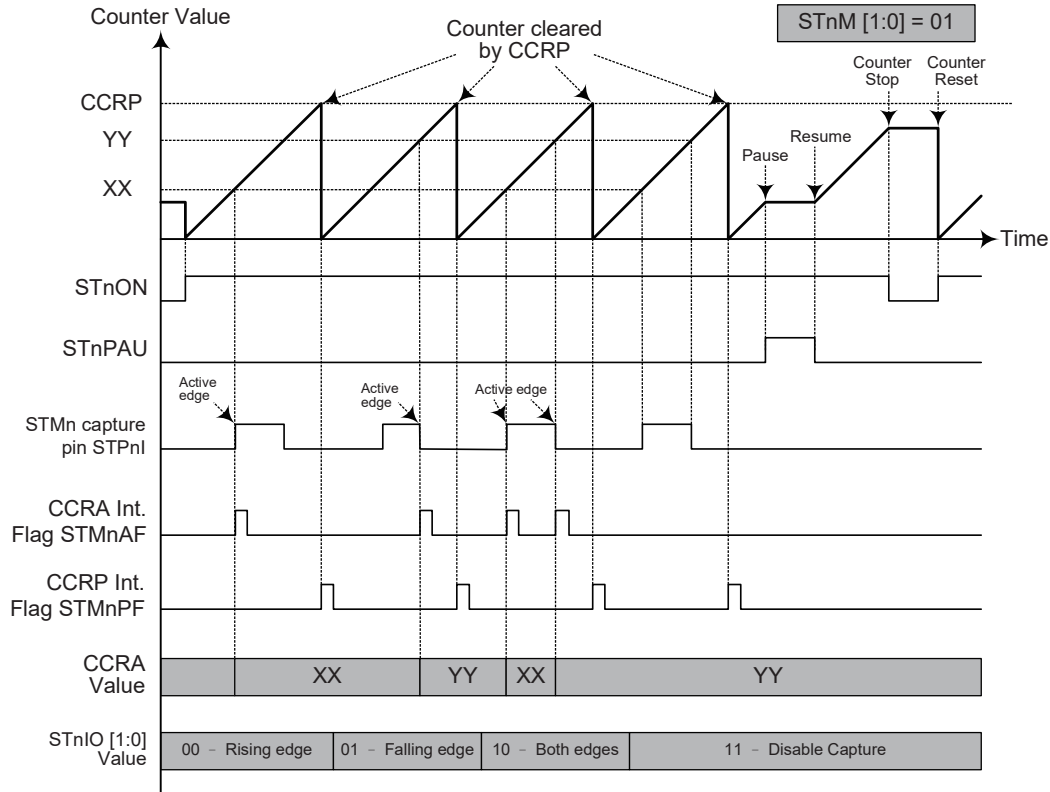

**Capture Input Mode**

- Note: 1. STnM [1:0]=01 and active edge set by the STnIO [1:0] bits  
 2. A STMn Capture input pin active edge transfers the counter value to CCRA  
 3. STnCCLR bit not used  
 4. No output function -- STnOC and STnPOL bits are not used  
 5. CCRP determines the counter value and the counter has a maximum count value when CCRP is equal to zero.  
 6. n=0 ~ 2

## Periodic Type TM – PTM

The Periodic Type TM contains five operating modes, which are Compare Match Output, Timer/Event Counter, Capture Input, Single Pulse Output and PWM Output modes. The Periodic TM can also be controlled with two external input pins and can drive two external output pin.

| Device                 | PTM Core                   | PTM Input Pin                | PTM Output Pin |
|------------------------|----------------------------|------------------------------|----------------|
| HT66F2350<br>HT66F2360 | 10-bit PTM<br>(PTM0, PTM1) | PTCK0, PTP0I<br>PTCK1, PTP1I | PTP0<br>PTP1   |
| HT66F2370<br>HT66F2390 | 16-bit PTM<br>(PTM2, PTM3) | PTCK2, PTP2I<br>PTCK3, PTP3I | PTP2<br>PTP3   |

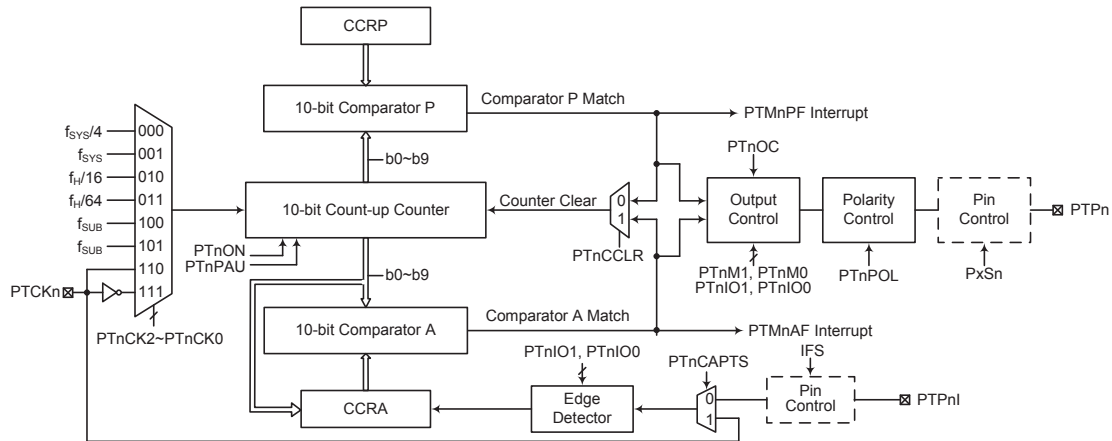

**10-bit Periodic Type TM Block Diagram (n=0 or 1)**

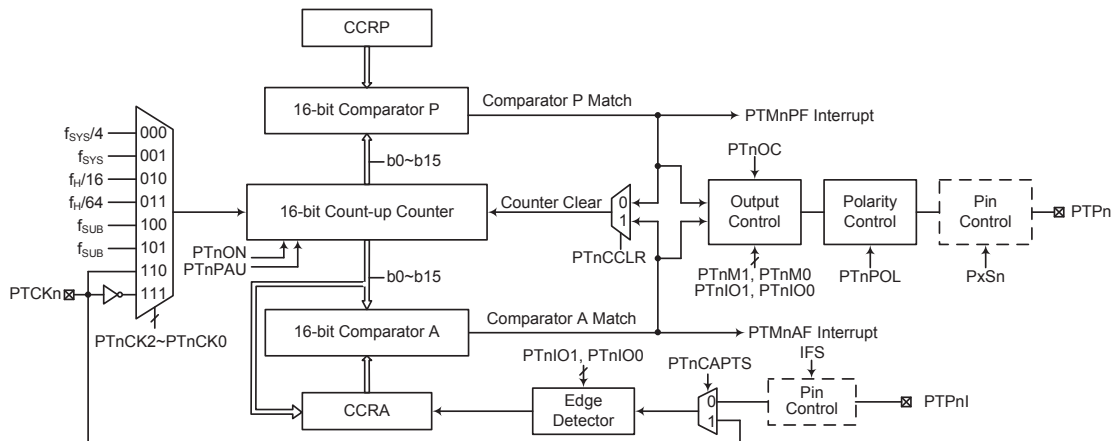

**16-bit Periodic Type TM Block Diagram (n=2 or 3)**

## Periodic TM Operation

The size of Periodic TM is 10-/16-bit wide and its core is a 10-/16-bit count-up counter which is driven by a user selectable internal or external clock source. There are also two internal comparators with the names, Comparator A and Comparator P. These comparators will compare the value in the counter with CCRP and CCRA registers. The CCRP and CCRA comparators are 10-/16-bit wide whose value is respectively compared with all counter bits.

The only way of changing the value of the 10-/16-bit counter using the application program is to clear the counter by changing the PTnON bit from low to high. The counter will also be cleared automatically by a counter overflow or a compare match with one of its associated comparators. When these conditions occur, a PTM interrupt signal will also usually be generated. The Periodic Type TM can operate in a number of different operational modes, can be driven by different clock sources including an input pin and can also control the output pins. All operating setup conditions are selected using relevant internal registers.

## Periodic Type TM Register Description

Overall operation of the Periodic TM is controlled using a series of registers. A read only register pair exists to store the internal counter 10-/16-bit value, while two read/write register pairs exist to store the internal 10-/16-bit CCRA and CCRP value. The remaining two registers are control registers which setup the different operating and control modes.

| Register Name | Bit    |        |        |        |        |        |          |         |
|---------------|--------|--------|--------|--------|--------|--------|----------|---------|
|               | 7      | 6      | 54     | 4      | 3      | 2      | 1        | 0       |
| PTMnC0        | PTnPAU | PTnCK2 | PTnCK1 | PTnCK0 | PTnON  | —      | —        | —       |
| PTMnC1        | PTnM1  | PTnM0  | PTnIO1 | PTnIO0 | PTnOC  | PTnPOL | PTnCAPTS | PTnCCLR |
| PTMnDL        | D7     | D6     | D5     | D4     | D3     | D2     | D1       | D0      |
| PTMnDH        | —      | —      | —      | —      | —      | —      | D9       | D8      |
| PTMnAL        | D7     | D6     | D5     | D4     | D3     | D2     | D1       | D0      |
| PTMnAH        | —      | —      | —      | —      | —      | —      | D9       | D8      |
| PTMnRPL       | PTnRP7 | PTnRP6 | PTnRP5 | PTnRP4 | PTnRP3 | PTnRP2 | PTnRP1   | PTnRP0  |
| PTMnRPH       | —      | —      | —      | —      | —      | —      | PTnRP9   | PTnRP8  |

**10-bit Periodic TM Registers List (n=0 or 1)**

| Register Name | Bit     |         |         |         |         |         |          |         |
|---------------|---------|---------|---------|---------|---------|---------|----------|---------|
|               | 7       | 6       | 5       | 4       | 3       | 2       | 1        | 0       |
| PTMnC0        | PTnPAU  | PTnCK2  | PTnCK1  | PTnCK0  | PTnON   | —       | —        | —       |
| PTMnC1        | PTnM1   | PTnM0   | PTnIO1  | PTnIO0  | PTnOC   | PTnPOL  | PTnCAPTS | PTnCCLR |
| PTMnDL        | D7      | D6      | D5      | D4      | D3      | D2      | D1       | D0      |
| PTMnDH        | D15     | D14     | D13     | D12     | D11     | D10     | D9       | D8      |
| PTMnAL        | D7      | D6      | D5      | D4      | D3      | D2      | D1       | D0      |
| PTMnAH        | D15     | D14     | D13     | D12     | D11     | D10     | D9       | D8      |
| PTMnRPL       | PTnRP7  | PTnRP6  | PTnRP5  | PTnRP4  | PTnRP3  | PTnRP2  | PTnRP1   | PTnRP0  |
| PTMnRPH       | PTnRP15 | PTnRP14 | PTnRP13 | PTnRP12 | PTnRP11 | PTnRP10 | PTnRP9   | PTnRP8  |

**16-bit Periodic TM Registers List (n=2 or 3)**

• **PTMnDL Register**

| Bit  | 7  | 6  | 5  | 4  | 3  | 2  | 1  | 0  |
|------|----|----|----|----|----|----|----|----|
| Name | D7 | D6 | D5 | D4 | D3 | D2 | D1 | D0 |
| R/W  | R  | R  | R  | R  | R  | R  | R  | R  |
| POR  | 0  | 0  | 0  | 0  | 0  | 0  | 0  | 0  |

Bit 7~0 PTMn Counter Low Byte Register bit 7 ~ bit 0  
PTMn 10/16-bit Counter bit 7 ~ bit 0

• **PTMnDH Register (n=0 or 1)**

| Bit  | 7 | 6 | 5 | 4 | 3 | 2 | 1  | 0  |
|------|---|---|---|---|---|---|----|----|
| Name | — | — | — | — | — | — | D9 | D8 |
| R/W  | — | — | — | — | — | — | R  | R  |
| POR  | — | — | — | — | — | — | 0  | 0  |

Bit 7~2 Unimplemented, read as "0"  
Bit 1~0 PTMn Counter High Byte Register bit 1 ~ bit 0  
PTMn 10-bit Counter bit 9 ~ bit 8

• **PTMnDH Register (n=2 or 3)**

| Bit  | 7   | 6   | 5   | 4   | 3   | 2   | 1  | 0  |
|------|-----|-----|-----|-----|-----|-----|----|----|
| Name | D15 | D14 | D13 | D12 | D11 | D10 | D9 | D8 |
| R/W  | R   | R   | R   | R   | R   | R   | R  | R  |
| POR  | 0   | 0   | 0   | 0   | 0   | 0   | 0  | 0  |

Bit 7~0 PTMn Counter High Byte Register bit 7 ~ bit 0  
PTMn 16-bit Counter bit 15 ~ bit 8

• **PTMnAL Register**

| Bit  | 7   | 6   | 5   | 4   | 3   | 2   | 1   | 0   |
|------|-----|-----|-----|-----|-----|-----|-----|-----|
| Name | D7  | D6  | D5  | D4  | D3  | D2  | D1  | D0  |
| R/W  | R/W | R/W | R/W | R/W | R/W | R/W | R/W | R/W |
| POR  | 0   | 0   | 0   | 0   | 0   | 0   | 0   | 0   |

Bit 7~0 PTMn CCRA Low Byte Register bit 7 ~ bit 0  
PTMn 10/16-bit CCRA bit 7 ~ bit 0

• **PTMnAH Register (n=0 or 1)**

| Bit  | 7 | 6 | 5 | 4 | 3 | 2 | 1   | 0   |
|------|---|---|---|---|---|---|-----|-----|
| Name | — | — | — | — | — | — | D9  | D8  |
| R/W  | — | — | — | — | — | — | R/W | R/W |
| POR  | — | — | — | — | — | — | 0   | 0   |

Bit 7~2 Unimplemented, read as "0"  
Bit 1~0 PTMn CCRA High Byte Register bit 1 ~ bit 0  
PTMn 10-bit CCRA bit 9 ~ bit 8

• **PTMnAH Register (n=2 or 3)**

| Bit  | 7   | 6   | 5   | 4   | 3   | 2   | 1   | 0   |
|------|-----|-----|-----|-----|-----|-----|-----|-----|
| Name | D15 | D14 | D13 | D12 | D11 | D10 | D9  | D8  |
| R/W  | R/W | R/W | R/W | R/W | R/W | R/W | R/W | R/W |
| POR  | 0   | 0   | 0   | 0   | 0   | 0   | 0   | 0   |

Bit 7~0 PTMn CCRA High Byte Register bit 7 ~ bit 0  
PTMn 16-bit CCRA bit 15 ~ bit 8

• **PTMnRPL Register**

| Bit  | 7      | 6      | 5      | 4      | 3      | 2      | 1      | 0      |
|------|--------|--------|--------|--------|--------|--------|--------|--------|
| Name | PTnRP7 | PTnRP6 | PTnRP5 | PTnRP4 | PTnRP3 | PTnRP2 | PTnRP1 | PTnRP0 |
| R/W  | R/W    | R/W    | R/W    | R/W    | R/W    | R/W    | R/W    | R/W    |
| POR  | 0      | 0      | 0      | 0      | 0      | 0      | 0      | 0      |

Bit 7~0 **PTnRP7~PTnRP0**: PTMn CCRP Low Byte Register bit 7 ~ bit 0  
 PTMn 10/16-bit CCRP bit 7 ~ bit 0

• **PTMnRPH Register (n=0 or 1)**

| Bit  | 7 | 6 | 5 | 4 | 3 | 2 | 1      | 0      |
|------|---|---|---|---|---|---|--------|--------|
| Name | — | — | — | — | — | — | PTnRP9 | PTnRP8 |
| R/W  | — | — | — | — | — | — | R/W    | R/W    |
| POR  | — | — | — | — | — | — | 0      | 0      |

Bit 7~2 Unimplemented, read as "0"

Bit 1~0 **PTnRP9~PTnRP8**: PTMn CCRP High Byte Register bit 1 ~ bit 0  
 PTMn 10-bit CCRP bit 9 ~ bit 8

• **PTMnRPH Register (n=2 or 3)**

| Bit  | 7       | 6       | 5       | 4       | 3       | 2       | 1      | 0      |
|------|---------|---------|---------|---------|---------|---------|--------|--------|
| Name | PTnRP15 | PTnRP14 | PTnRP13 | PTnRP12 | PTnRP11 | PTnRP10 | PTnRP9 | PTnRP8 |
| R/W  | R/W     | R/W     | R/W     | R/W     | R/W     | R/W     | R/W    | R/W    |
| POR  | 0       | 0       | 0       | 0       | 0       | 0       | 0      | 0      |

Bit 7~0 **PTnRP15~PTnRP8**: PTMn CCRP High Byte Register bit 7 ~ bit 0  
 PTMn 16-bit CCRP bit 15 ~ bit 8

• **PTMnC0 Register**

| Bit  | 7      | 6      | 5      | 4      | 3     | 2 | 1 | 0 |
|------|--------|--------|--------|--------|-------|---|---|---|
| Name | PTnPAU | PTnCK2 | PTnCK1 | PTnCK0 | PTnON | — | — | — |
| R/W  | R/W    | R/W    | R/W    | R/W    | R/W   | — | — | — |
| POR  | 0      | 0      | 0      | 0      | 0     | — | — | — |

Bit 7 **PTnPAU**: PTMn Counter Pause control  
 0: Run  
 1: Pause

The counter can be paused by setting this bit high. Clearing the bit to zero restores normal counter operation. When in a Pause condition the PTMn will remain powered up and continue to consume power. The counter will retain its residual value when this bit changes from low to high and resume counting from this value when the bit changes to a low value again.

Bit 6~4 **PTnCK2~PTnCK0**: Select PTMn Counter clock

000:  $f_{SYS}/4$   
 001:  $f_{SYS}$   
 010:  $f_H/16$   
 011:  $f_H/64$   
 100:  $f_{SUB}$   
 101:  $f_{SUB}$   
 110: PTCKn rising edge clock  
 111: PTCKn falling edge clock

These three bits are used to select the clock source for the PTMn. The external pin clock source can be chosen to be active on the rising or falling edge. The clock source  $f_{SYS}$  is the system clock, while  $f_H$  and  $f_{SUB}$  are other internal clocks, the details of which can be found in the oscillator section.

Bit 3      **PTnON**: PTMn Counter On/Off control  
             0: Off  
             1: On

This bit controls the overall on/off function of the PTMn. Setting the bit high enables the counter to run while clearing the bit disables the PTMn. Clearing this bit to zero will stop the counter from counting and turn off the PTMn which will reduce its power consumption. When the bit changes state from low to high the internal counter value will be reset to zero, however when the bit changes from high to low, the internal counter will retain its residual value until the bit returns high again. If the PTMn is in the Compare Match Output Mode then the PTMn output pin will be reset to its initial condition, as specified by the PTnOC bit, when the PTnON bit changes from low to high.

Bit 2~0      Unimplemented, read as "0"

• **PTMnC1 Register**

| Bit  | 7     | 6     | 5      | 4      | 3     | 2      | 1        | 0       |
|------|-------|-------|--------|--------|-------|--------|----------|---------|
| Name | PTnM1 | PTnM0 | PTnIO1 | PTnIO0 | PTnOC | PTnPOL | PTnCAPTS | PTnCCLR |
| R/W  | R/W   | R/W   | R/W    | R/W    | R/W   | R/W    | R/W      | R/W     |
| POR  | 0     | 0     | 0      | 0      | 0     | 0      | 0        | 0       |

Bit 7~6      **PTnM1~PTnM0**: Select PTMn Operating Mode  
             00: Compare Match Output Mode  
             01: Capture Input Mode  
             10: PWM Mode or Single Pulse Output Mode  
             11: Timer/Counter Mode

These bits setup the required operating mode for the PTMn. To ensure reliable operation the PTMn should be switched off before any changes are made to the PTnM1 and PTnM0 bits. In the Timer/Counter Mode, the PTMn output pin control will be disabled.

Bit 5~4      **PTnIO1~PTnIO0**: Select PTMn external pin PTPn or PTPnI function

Compare Match Output Mode

- 00: No change
- 01: Output low
- 10: Output high
- 11: Toggle output

PWM Output Mode/Single Pulse Output Mode

- 00: PWM output inactive state
- 01: PWM output active state
- 10: PWM output
- 11: Single Pulse Output

Capture Input Mode

- 00: Input capture at rising edge of PTPnI or PTCKn
- 01: Input capture at falling edge of PTPnI or PTCKn
- 10: Input capture at rising/falling edge of PTPnI or PTCKn
- 11: Input capture disabled

Timer/Counter Mode

Unused

These two bits are used to determine how the PTMn output pin changes state when a certain condition is reached. The function that these bits select depends upon in which mode the PTMn is running.

In the Compare Match Output Mode, the PTnIO1 and PTnIO0 bits determine how the PTMn output pin changes state when a compare match occurs from the Comparator A. The PTMn output pin can be setup to switch high, switch low or to toggle its present state when a compare match occurs from the Comparator A. When the bits are both zero, then no change will take place on the output. The initial value of the PTMn output pin should be setup using the PTnOC bit in the PTMnC1 register. Note that

the output level requested by the PTnIO1 and PTnIO0 bits must be different from the initial value setup using the PTnOC bit otherwise no change will occur on the PTMn output pin when a compare match occurs. After the PTMn output pin changes state, it can be reset to its initial level by changing the level of the PTnON bit from low to high.

In the PWM Output Mode, the PTnIO1 and PTnIO0 bits determine how the TM output pin changes state when a certain compare match condition occurs. The PTMn output function is modified by changing these two bits. It is necessary to only change the values of the PTnIO1 and PTnIO0 bits only after the PTMn has been switched off. Unpredictable PWM outputs will occur if the PTnIO1 and PTnIO0 bits are changed when the PTMn is running.

- Bit 3     **PTnOC**: PTMn PTPn Output control  
Compare Match Output Mode  
    0: Initial low  
    1: Initial high  
PWM Output Mode/Single Pulse Output Mode  
    0: Active low  
    1: Active high

This is the output control bit for the PTMn output pin. Its operation depends upon whether PTMn is being used in the Compare Match Output Mode or in the PWM Mode/Single Pulse Output Mode. It has no effect if the PTMn is in the Timer/Counter Mode. In the Compare Match Output Mode it determines the logic level of the PTMn output pin before a compare match occurs. In the PWM Mode/Single Pulse Output Mode it determines if the PWM signal is active high or active low.

- Bit 2     **PTnPOL**: PTMn PTPn Output polarity control  
    0: Non-inverted  
    1: Inverted

This bit controls the polarity of the PTPn output pin. When the bit is set high the PTMn output pin will be inverted and not inverted when the bit is zero. It has no effect if the PTMn is in the Timer/Counter Mode.

- Bit 1     **PTnCAPTS**: PTMn Capture Trigger Source selection  
    0: From PTPnI pin  
    1: From PTCKn pin

- Bit 0     **PTnCCLR**: PTMn Counter Clear condition selection  
    0: Comparator P match  
    1: Comparator A match

This bit is used to select the method which clears the counter. Remember that the Periodic TM contains two comparators, Comparator A and Comparator P, either of which can be selected to clear the internal counter. With the PTnCCLR bit set high, the counter will be cleared when a compare match occurs from the Comparator A. When the bit is low, the counter will be cleared when a compare match occurs from the Comparator P or with a counter overflow. A counter overflow clearing method can only be implemented if the CCRP bits are all cleared to zero. The PTnCCLR bit is not used in the PWM Output, Single Pulse Output or Capture Input Mode.

## Periodic Type TM Operation Modes

The Periodic Type TM can operate in one of five operating modes, Compare Match Output Mode, PWM Output Mode, Single Pulse Output Mode, Capture Input Mode or Timer/Counter Mode. The operating mode is selected using the PTnM1 and PTnM0 bits in the PTMnC1 register.

### Compare Match Output Mode

To select this mode, bits PTnM1 and PTnM0 in the PTMnC1 register, should be set to 00 respectively. In this mode once the counter is enabled and running it can be cleared by three methods. These are a counter overflow, a compare match from Comparator A and a compare match from Comparator P. When the PTnCCLR bit is low, there are two ways in which the counter can be cleared. One is when a compare match from Comparator P, the other is when the CCRP bits are all zero which allows the counter to overflow. Here both PTMnAF and PTMnPF interrupt request flags for Comparator A and Comparator P respectively, will both be generated.

If the PTnCCLR bit in the PTMnC1 register is high then the counter will be cleared when a compare match occurs from Comparator A. However, here only the PTMnAF interrupt request flag will be generated even if the value of the CCRP bits is less than that of the CCRA registers. Therefore when PTnCCLR is high no PTMnPF interrupt request flag will be generated. In the Compare Match Output Mode, the CCRA can not be set to "0".

As the name of the mode suggests, after a comparison is made, the PTMn output pin will change state. The PTMn output pin condition however only changes state when a PTMnAF interrupt request flag is generated after a compare match occurs from Comparator A. The PTMnPF interrupt request flag, generated from a compare match occurs from Comparator P, will have no effect on the PTMn output pin. The way in which the PTMn output pin changes state are determined by the condition of the PTnIO1 and PTnIO0 bits in the PTMnC1 register. The PTMn output pin can be selected using the PTnIO1 and PTnIO0 bits to go high, to go low or to toggle from its present condition when a compare match occurs from Comparator A. The initial condition of the PTMn output pin, which is setup after the PTnON bit changes from low to high, is setup using the PTnOC bit. Note that if the PTnIO1 and PTnIO0 bits are zero then no pin change will take place.

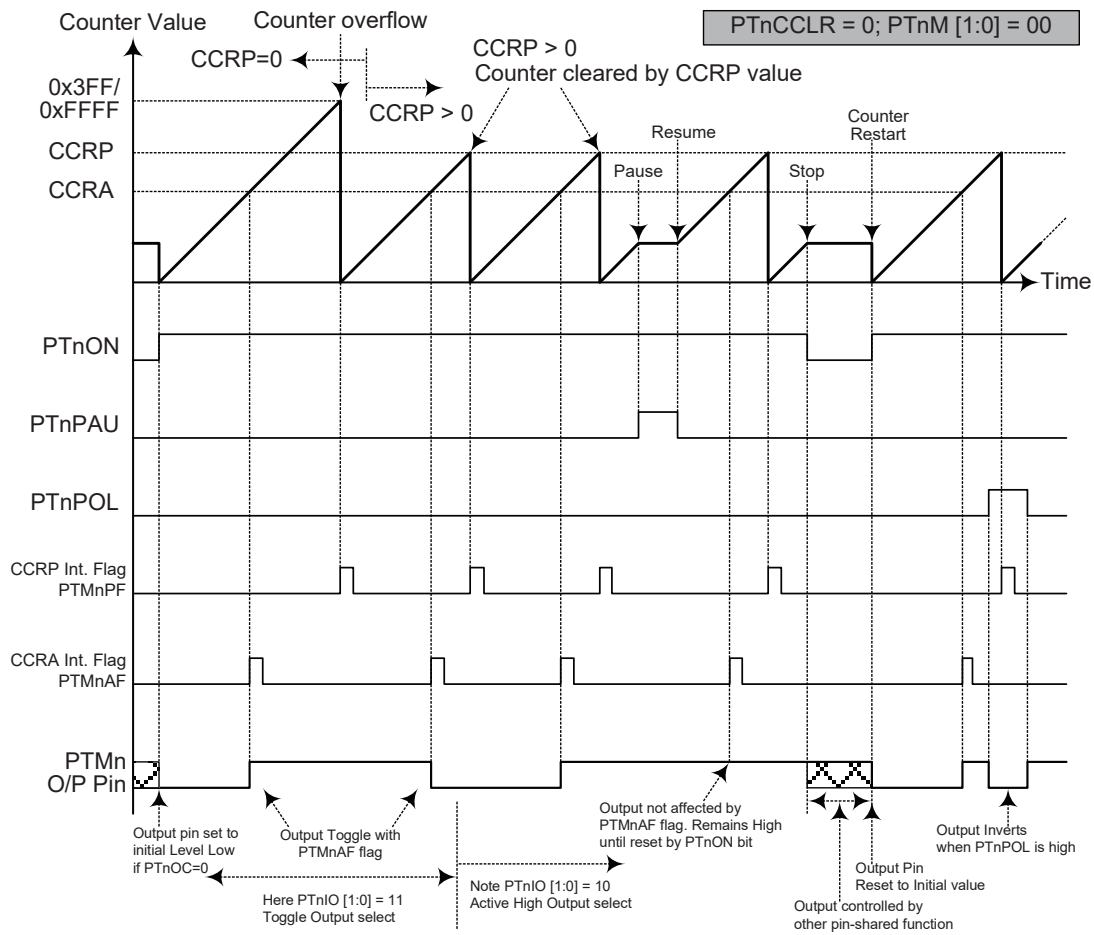

**Compare Match Output Mode – PTnCCR=0**

- Note: 1. With PTnCCR=0, a Comparator P match will clear the counter
2. The PTMn output pin is controlled only by the PTMnAF flag
3. The output pin is reset to its initial state by a PTnON bit rising edge
4. The 10-bit PTM maximum counter value is 0x3FF while the 16-bit PTM maximum counter value is 0xFFFF.
5. n=0 or 1 for 10-bit PTM while n=2 or 3 for 16-bit PTM

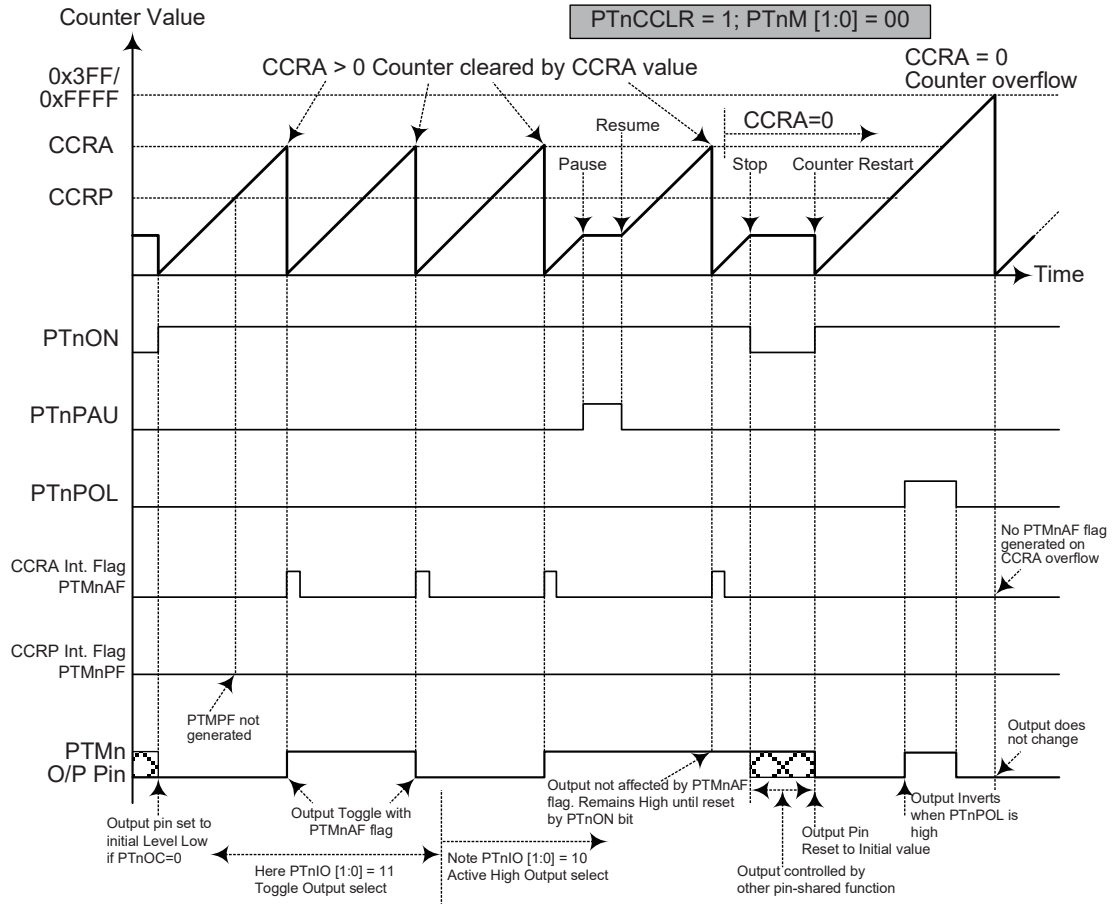

**Compare Match Output Mode – PTnCCLR=1**

- Note: 1. With PTnCCLR=1, a Comparator A match will clear the counter  
 2. The PTMn output pin is controlled only by the PTMnAF flag  
 3. The output pin is reset to its initial state by a PTnON bit rising edge  
 4. A PTMnPF flag is not generated when PTnCCLR =1  
 5. The 10-bit PTM maximum counter value is 0x3FF while the 16-bit PTM maximum counter value is 0xFFFF.  
 6. n=0 or 1 for 10-bit PTM while n=2 or 3 for 16-bit PTM

### Timer/Counter Mode

To select this mode, bits PTnM1 and PTnM0 in the PTMnC1 register should be set to 11 respectively. The Timer/Counter Mode operates in an identical way to the Compare Match Output Mode generating the same interrupt flags. The exception is that in the Timer/Counter Mode the PTMn output pin is not used. Therefore the above description and Timing Diagrams for the Compare Match Output Mode can be used to understand its function. As the PTMn output pin is not used in this mode, the pin can be used as a normal I/O pin or other pin-shared function.

### PWM Output Mode

To select this mode, bits PTnM1 and PTnM0 in the PTMnC1 register should be set to 10 respectively and also the PTnIO1 and PTnIO0 bits should be set to 10 respectively. The PWM function within the PTMn is useful for applications which require functions such as motor control, heating control, illumination control, etc. By providing a signal of fixed frequency but of varying duty cycle on the PTMn output pin, a square wave AC waveform can be generated with varying equivalent DC RMS values.

As both the period and duty cycle of the PWM waveform can be controlled, the choice of generated waveform is extremely flexible. In the PWM mode, the PTnCCLR bit has no effect as the PWM period. Both of the CCRP and CCRA registers are used to generate the PWM waveform, one register is used to clear the internal counter and thus control the PWM waveform frequency, while the other one is used to control the duty cycle. The PWM waveform frequency and duty cycle can therefore be controlled by the values in the CCRA and CCRP registers.

An interrupt flag, one for each of the CCRA and CCRP, will be generated when a compare match occurs from either Comparator A or Comparator P. The PTnOC bit in the PTMnC1 register is used to select the required polarity of the PWM waveform while the two PTnIO1 and PTnIO0 bits are used to enable the PWM output or to force the PTMn output pin to a fixed high or low level. The PTnPOL bit is used to reverse the polarity of the PWM output waveform.

- **16-bit PTMn, PWM Mode,**

| CCRP   | 1~65535 | 0     |
|--------|---------|-------|
| Period | 1~65535 | 65536 |
| Duty   | CCRA    |       |

If  $f_{SYS}=16\text{MHz}$ , TM clock source select  $f_{SYS}/4$ , CCRP=512 and CCRA=128,

The PTMn PWM output frequency= $(f_{SYS}/4)/512=f_{SYS}/2048=8\text{kHz}$ , duty=128/512=25%,

If the Duty value defined by the CCRA register is equal to or greater than the Period value, then the PWM output duty is 100%.

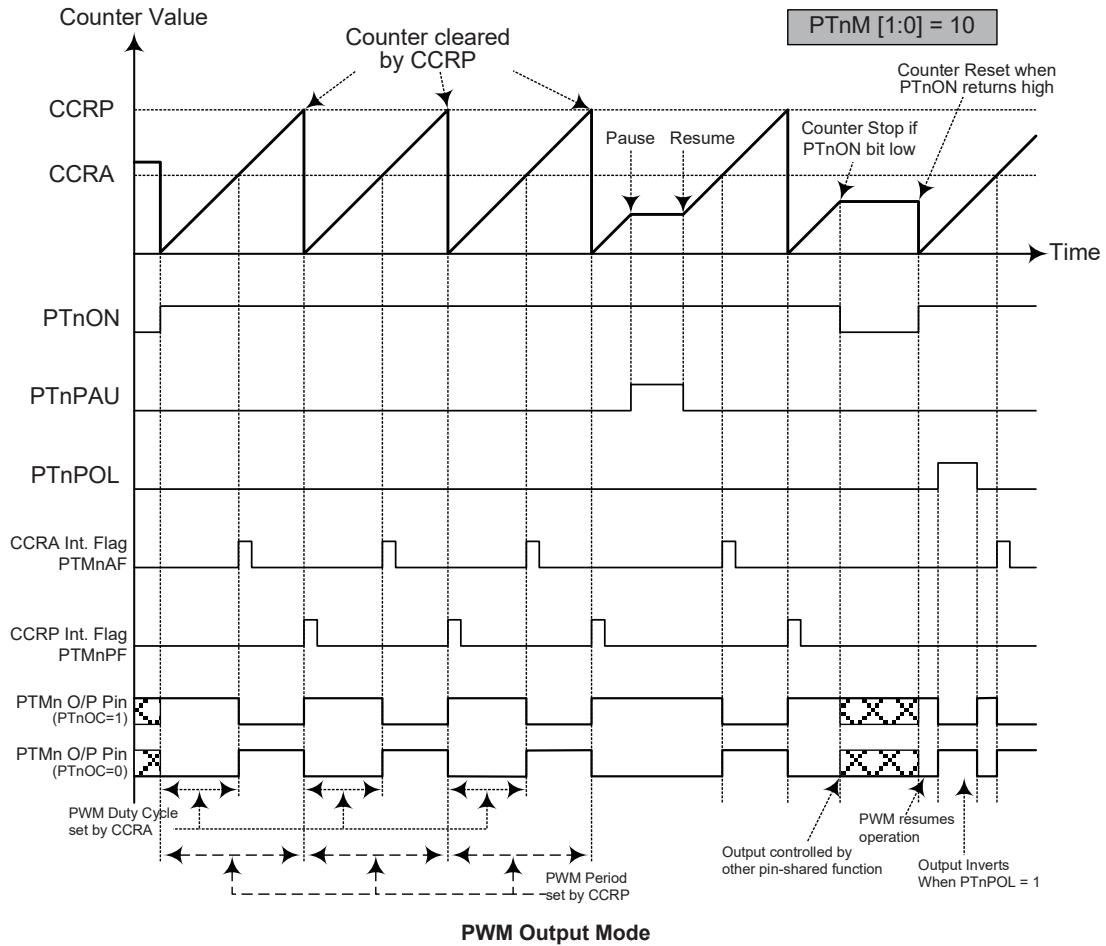

- Note:
1. The counter is cleared by CCRP.
  2. A counter clear sets the PWM Period
  3. The internal PWM function continues running even when PTnIO [1:0]=00 or 01
  4. The PTnCCLR bit has no influence on PWM operation
  5. n=0 or 1 for 10-bit PTM while n=2 or 3 for 16-bit PTM

### Single Pulse Output Mode

To select this mode, bits PTnM1 and PTnM0 in the PTMnC1 register should be set to 10 respectively and also the PTnIO1 and PTnIO0 bits should be set to 11 respectively. The Single Pulse Output Mode, as the name suggests, will generate a single shot pulse on the PTMn output pin.

The trigger for the pulse output leading edge is a low to high transition of the PTnON bit, which can be implemented using the application program. However in the Single Pulse Mode, the PTnON bit can also be made to automatically change from low to high using the external PTCKn pin, which will in turn initiate the Single Pulse output. When the PTnON bit transitions to a high level, the counter will start running and the pulse leading edge will be generated. The PTnON bit should remain high when the pulse is in its active state. The generated pulse trailing edge will be generated when the PTnON bit is cleared to zero, which can be implemented using the application program or when a compare match occurs from Comparator A.

However a compare match from Comparator A will also automatically clear the PTnON bit and thus generate the Single Pulse output trailing edge. In this way the CCRA value can be used to control the pulse width. A compare match from Comparator A will also generate a PTMn interrupt. The counter can only be reset back to zero when the PTnON bit changes from low to high when the counter restarts. In the Single Pulse Mode CCRP is not used. The PTnCCLR is not used in this Mode.

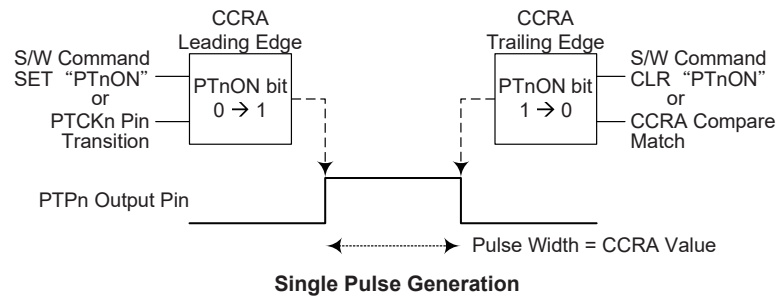

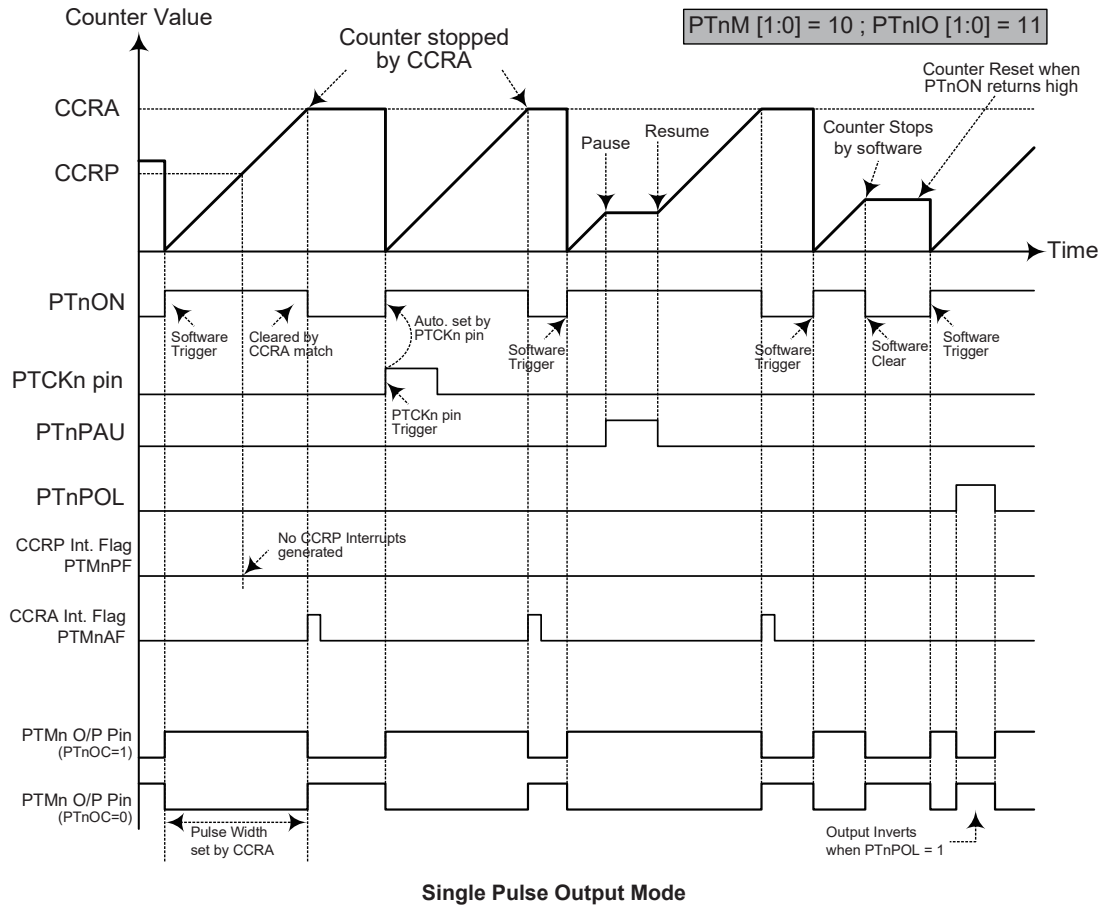

- Note: 1. Counter stopped by CCRA  
 2. CCRP is not used  
 3. The pulse triggered by the PTCKn pin or by setting the PTnON bit high  
 4. A PTCKn pin active edge will automatically set the PTnON bit high.  
 5. In the Single Pulse Mode, PTnIO [1:0] must be set to "11" and can not be changed.  
 6. n=0 or 1 for 10-bit PTM while n=2 or 3 for 16-bit PTM

### **Capture Input Mode**

To select this mode bits PTnM1 and PTnM0 in the PTMnC1 register should be set to 01 respectively. This mode enables external signals to capture and store the present value of the internal counter and can therefore be used for applications such as pulse width measurements. The external signal is supplied on the PTPnI or PTCKn pin, selected by the PTnCAPTS bit in the PTMnC1 register. The input pin active edge can be either a rising edge, a falling edge or both rising and falling edges; the active edge transition type is selected using the PTnIO1 and PTnIO0 bits in the PTMnC1 register. The counter is started when the PTnON bit changes from low to high which is initiated using the application program.

When the required edge transition appears on the PTPnI or PTCKn pin the present value in the counter will be latched into the CCRA registers and a PTMn interrupt generated. Irrespective of what events occur on the PTPnI or PTCKn pin the counter will continue to free run until the PTnON bit changes from high to low. When a CCRP compare match occurs the counter will reset back to zero; in this way the CCRP value can be used to control the maximum counter value. When a CCRP compare match occurs from Comparator P, a PTMn interrupt will also be generated. Counting the number of overflow interrupt signals from the CCRP can be a useful method in measuring long pulse widths. The PTnIO1 and PTnIO0 bits can select the active trigger edge on the PTPnI or PTCKn pin to be a rising edge, falling edge or both edge types. If the PTnIO1 and PTnIO0 bits are both set high, then no capture operation will take place irrespective of what happens on the PTPnI or PTCKn pin, however it must be noted that the counter will continue to run.

As the PTPnI or PTCKn pin is pin shared with other functions, care must be taken if the PTMn is in the Input Capture Mode. This is because if the pin is setup as an output, then any transitions on this pin may cause an input capture operation to be executed. The PTnCCLR, PTnOC and PTnPOL bits are not used in this Mode.

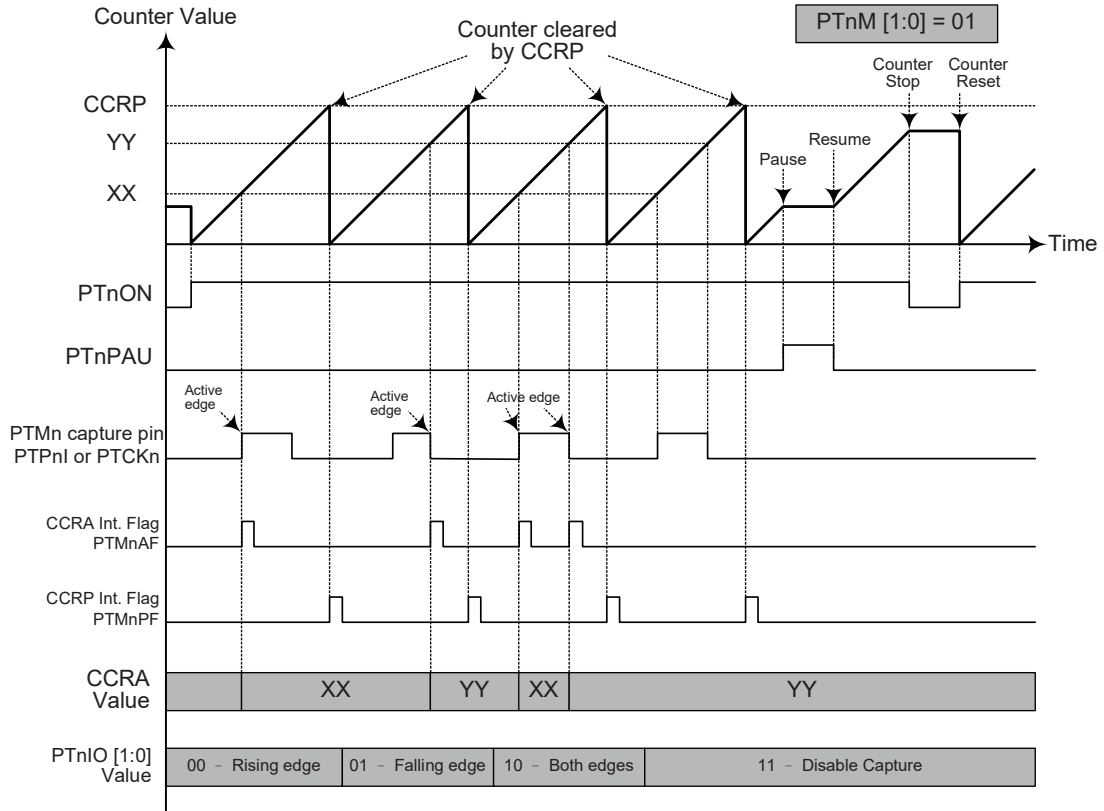

**Capture Input Mode**

- Note: 1. PTnM [1:0]=01 and active edge set by the PTnIO [1:0] bits  
 2. A PTMn Capture input pin active edge transfers the counter value to CCRA  
 3. PTnCCLR bit not used  
 4. No output function – PTnOC and PTnPOL bits are not used  
 5. CCRP determines the counter value and the counter has a maximum count value when CCRP is equal to zero.  
 6. n=0 or 1 for 10-bit PTM while n=2 or 3 for 16-bit PTM

## Analog to Digital Converter

The need to interface to real world analog signals is a common requirement for many electronic systems. However, to properly process these signals by a microcontroller, they must first be converted into digital signals by A/D converters. By integrating the A/D conversion electronic circuitry into the microcontroller, the need for external components is reduced significantly with the corresponding follow-on benefits of lower costs and reduced component space requirements.

### A/D Overview

These devices contain a multi-channel analog to digital converter which can directly interface to external analog signals, such as that from sensors or other control signals and convert these signals directly into a 12-bit digital value. It also can convert the internal signals, such as the internal reference voltage, into a 12-bit digital value. The external or internal analog signal to be converted is determined by the SAINS and SACS bit fields. Note that when the internal analog signal is selected to be converted using the SAINS field, the external channel analog input will automatically be switched off. More detailed information about the A/D input signal selection will be described in the "A/D Converter Input Signals" section.

The accompanying block diagram shows the internal structure of the A/D converter with its associated registers and control bits.

| Device    | External Input Channels | Internal Signal  | A/D Signal Select            |
|-----------|-------------------------|--|------------------------------|
| HT66F2350 | AN0~AN11                | AV <sub>DD</sub> , AV <sub>DD</sub> /2, AV <sub>DD</sub> /4,<br>V <sub>R</sub> , V <sub>R</sub> /2, V <sub>R</sub> /4, | SAINS3~SAINS0<br>SACS3~SACS0 |
| HT66F2360 | AN0~AN15                |  |                              |
| HT66F2370 |                         |  |                              |
| HT66F2390 |                         |  |                              |

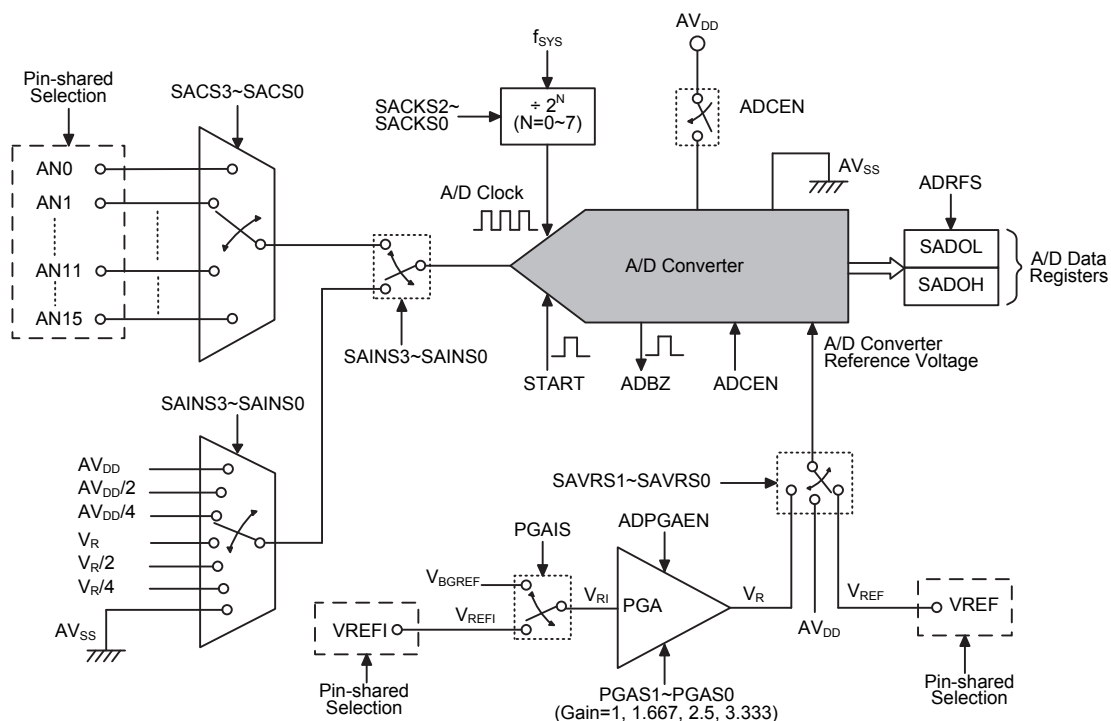

Note: The external channel is from AN0 to AN11 for the HT66F2350 device.

### A/D Converter Structure

## Registers Descriptions

Overall operation of the A/D converter is controlled using five registers. A read only register pair exists to store the A/D Converter data 12-bit value. Three registers, SADC0, SADC1 and SADC2, are the control registers which setup the operating conditions and control function of the A/D converter.

| Register Name   | Bit     |        |        |        |        |        |        |        |
|-----------------|---------|--------|--------|--------|--------|--------|--------|--------|
|                 | 7       | 6      | 5      | 4      | 3      | 2      | 1      | 0      |
| SADOL (ADRFS=0) | D3      | D2     | D1     | D0     | —      | —      | —      | —      |
| SADOL (ADRFS=1) | D7      | D6     | D5     | D4     | D3     | D2     | D1     | D0     |
| SADOH (ADRFS=0) | D11     | D10    | D9     | D8     | D7     | D6     | D5     | D4     |
| SADOH (ADRFS=1) | —       | —      | —      | —      | D11    | D10    | D9     | D8     |
| SADC0           | START   | ADBZ   | ADCEN  | ADRFS  | SACS3  | SACS2  | SACS1  | SACS0  |
| SADC1           | SAINS3  | SAINS2 | SAINS1 | SAINS0 | —      | SACKS2 | SACKS1 | SACKS0 |
| SADC2           | ADPGAEN | —      | —      | PGAIS  | SAVRS1 | SAVRS0 | PGAGS1 | PGAGS0 |
| VBGRC           | —       | —      | —      | —      | —      | —      | —      | VBGREN |

**A/D Converter Registers List**

### A/D Converter Data Registers – SADOL, SADOH

As these devices contain an internal 12-bit A/D converter, it requires two data registers to store the converted value. These are a high byte register, known as SADOH, and a low byte register, known as SADOL. After the conversion process takes place, these registers can be directly read by the microcontroller to obtain the digitised conversion value. As only 12 bits of the 16-bit register space is utilised, the format in which the data is stored is controlled by the ADRFS bit in the SADC0 register as shown in the accompanying table. D0~D11 are the A/D conversion result data bits. Any unused bits will be read as zero. The A/D data registers contents will be unchanged if the A/D converter is disabled.

| ADRFS | SADOH |     |    |    |     |     |    |    | SADOL |    |    |    |    |    |    |    |
|-------|-------|-----|----|----|-----|-----|----|----|-------|----|----|----|----|----|----|----|
|       | 7     | 6   | 5  | 4  | 3   | 2   | 1  | 0  | 7     | 6  | 5  | 4  | 3  | 2  | 1  | 0  |
| 0     | D11   | D10 | D9 | D8 | D7  | D6  | D5 | D4 | D3    | D2 | D1 | D0 | 0  | 0  | 0  | 0  |
| 1     | 0     | 0   | 0  | 0  | D11 | D10 | D9 | D8 | D7    | D6 | D5 | D4 | D3 | D2 | D1 | D0 |

**A/D Converter Data Registers**

### A/D Converter Control Registers – SADC0, SADC1, SADC2

To control the function and operation of the A/D converter, three control registers known as SADC0, SADC1 and SADC2 are provided. These 8-bit registers define functions such as the selection of which analog signal is connected to the internal A/D converter, the digitised data format, the A/D clock source as well as controlling the start function and monitoring the A/D converter busy status. As these devices contain only one actual analog to digital converter hardware circuit, each of the external and internal analog signals must be routed to the converter. The SAINS field in the SADC1 register and SACS field in the SADC0 register are used to determine which analog signal derived from the external or internal signals will be connected to the A/D converter. The A/D converter also contains a programmable gain amplifier, PGA, to generate the A/D converter internal reference voltage. The overall operation of the PGA is controlled using the SADC2 register.

The relevant pin-shared function selection bits determine which pins on I/O Ports are used as analog inputs for the A/D converter input and which pins are not. When the pin is selected to be an A/D input, its original function whether it is an I/O or other pin-shared function will be removed. In addition, any internal pull-high resistor connected to the pin will be automatically removed if the pin is selected to be an A/D converter input.

• **SADC0 Register – HT66F2350**

| Bit  | 7     | 6    | 5     | 4     | 3     | 2     | 1     | 0     |
|------|-------|------|-------|-------|-------|-------|-------|-------|
| Name | START | ADBZ | ADCEN | ADRFS | SACS3 | SACS2 | SACS1 | SACS0 |
| R/W  | R/W   | R    | R/W   | R/W   | R/W   | R/W   | R/W   | R/W   |
| POR  | 0     | 0    | 0     | 0     | 0     | 0     | 0     | 0     |

- Bit 7**      **START:** Start the A/D Conversion  
0→1→0: Start  
This bit is used to initiate an A/D conversion process. The bit is normally low but if set high and then cleared low again, the A/D converter will initiate a conversion process.
- Bit 6**      **ADBZ:** A/D Converter busy flag  
0: No A/D conversion is in progress  
1: A/D conversion is in progress  
This read only flag is used to indicate whether the A/D conversion is in progress or not. When the START bit is set from low to high and then to low again, the ADBZ flag will be set to 1 to indicate that the A/D conversion is initiated. The ADBZ flag will be cleared to 0 after the A/D conversion is complete.
- Bit 5**      **ADCEN:** A/D Converter function enable control  
0: Disable  
1: Enable  
This bit controls the A/D internal function. This bit should be set to one to enable the A/D converter. If the bit is set low, then the A/D converter will be switched off reducing the device power consumption. When the A/D converter function is disabled, the contents of the A/D data register pair known as SADOH and SADOL will be unchanged.
- Bit 4**      **ADRFS:** A/D conversion data format select  
0: A/D converter data format → SADOH=D [11:4]; SADOL=D [3:0]  
1: A/D converter data format → SADOH=D [11:8]; SADOL=D [7:0]  
This bit controls the format of the 12-bit converted A/D value in the two A/D data registers. Details are provided in the A/D converter data register section.
- Bit 3~0**    **SACS3~SACS0:** A/D converter external analog input channel select  
0000: External AN0 input  
0001: External AN1 input  
0010: External AN2 input  
0011: External AN3 input  
0100: External AN4 input  
0101: External AN5 input  
0110: External AN6 input  
0111: External AN7 input  
1000: External AN8 input  
1001: External AN9 input  
1010: External AN10 input  
1011: External AN11 input  
11xx: Undefined, input floating.  
These bits are used to select which external analog input channel is to be converted. When the external analog input channel is selected, the SAINS bit field must set to "0000", "0100" or "11xx". Details are summarized in the "A/D Converter Input Signal Selection" table.

• **SADC0 Register – HT66F2360/HT66F2370/HT66F2390**

| Bit  | 7     | 6    | 5     | 4     | 3     | 2     | 1     | 0     |
|------|-------|------|-------|-------|-------|-------|-------|-------|
| Name | START | ADBZ | ADCEN | ADRFS | SACS3 | SACS2 | SACS1 | SACS0 |
| R/W  | R/W   | R    | R/W   | R/W   | R/W   | R/W   | R/W   | R/W   |
| POR  | 0     | 0    | 0     | 0     | 0     | 0     | 0     | 0     |

- Bit 7**      **START:** Start the A/D Conversion  
0→1→0: Start  
This bit is used to initiate an A/D conversion process. The bit is normally low but if set high and then cleared low again, the A/D converter will initiate a conversion process.
- Bit 6**      **ADBZ:** A/D Converter busy flag  
0: No A/D conversion is in progress  
1: A/D conversion is in progress  
This read only flag is used to indicate whether the A/D conversion is in progress or not. When the START bit is set from low to high and then to low again, the ADBZ flag will be set to 1 to indicate that the A/D conversion is initiated. The ADBZ flag will be cleared to 0 after the A/D conversion is complete.
- Bit 5**      **ADCEN:** A/D Converter function enable control  
0: Disable  
1: Enable  
This bit controls the A/D internal function. This bit should be set to one to enable the A/D converter. If the bit is set low, then the A/D converter will be switched off reducing the device power consumption. When the A/D converter function is disabled, the contents of the A/D data register pair known as SADOH and SADOL will be unchanged.
- Bit 4**      **ADRFS:** A/D conversion data format select  
0: A/D converter data format → SADOH=D [11:4]; SADOL=D [3:0]  
1: A/D converter data format → SADOH=D [11:8]; SADOL=D [7:0]  
This bit controls the format of the 12-bit converted A/D value in the two A/D data registers. Details are provided in the A/D converter data register section.
- Bit 3~0**    **SACS3~SACS0:** A/D converter external analog input channel select  
0000: External AN0 input  
0001: External AN1 input  
0010: External AN2 input  
0011: External AN3 input  
0100: External AN4 input  
0101: External AN5 input  
0110: External AN6 input  
0111: External AN7 input  
1000: External AN8 input  
1001: External AN9 input  
1010: External AN10 input  
1011: External AN11 input  
1100: External AN12 input  
1101: External AN13 input  
1110: External AN14 input  
1111: External AN15 input  
These bits are used to select which external analog input channel is to be converted. When the external analog input channel is selected, the SAINS bit field must set to "0000", "0100" or "11xx". Details are summarized in the "A/D Converter Input Signal Selection" table.

• **SADC1 Register**

| Bit  | 7      | 6      | 5      | 4      | 3 | 2      | 1      | 0      |
|------|--------|--------|--------|--------|---|--------|--------|--------|
| Name | SAINS3 | SAINS2 | SAINS1 | SAINS0 | — | SACKS2 | SACKS1 | SACKS0 |
| R/W  | R/W    | R/W    | R/W    | R/W    | — | R/W    | R/W    | R/W    |
| POR  | 0      | 0      | 0      | 0      | — | 0      | 0      | 0      |

- Bit 7~4 **SAINS3~SAINS0**: A/D converter input signal select  
 0000: External source – External analog channel input, ANn  
 0001: Internal source – Internal signal derived from AV<sub>DD</sub>  
 0010: Internal source – Internal signal derived from AV<sub>DD</sub>/2  
 0011: Internal source – Internal signal derived from AV<sub>DD</sub>/4  
 0100: External source – External analog channel input, ANn  
 0101: Internal source – Internal signal derived from PGA output V<sub>R</sub>  
 0110: Internal source – Internal signal derived from PGA output V<sub>R</sub>/2  
 0111: Internal source – Internal signal derived from PGA output V<sub>R</sub>/4  
 10xx: Internal source – Ground.  
 11xx: External source – External analog channel input, ANn

When the internal analog signal is selected to be converted, the external channel signal input will automatically be switched off regardless of the SACKS field value. It will prevent the external channel input from being connected together with the internal analog signal.

- Bit 3 Unimplemented, read as "0"
- Bit 2~0 **SACKS2~SACKS0**: A/D conversion clock source select  
 000: f<sub>sys</sub>  
 001: f<sub>sys</sub>/2  
 010: f<sub>sys</sub>/4  
 011: f<sub>sys</sub>/8  
 100: f<sub>sys</sub>/16  
 101: f<sub>sys</sub>/32  
 110: f<sub>sys</sub>/64  
 111: f<sub>sys</sub>/128

These bits are used to select the clock source for the A/D converter. It is recommended that the A/D conversion clock frequency should be in the range from 500 kHz to 1MHz by properly configuring the SACKS2~SACKS0 bits.

• **SADC2 Register**

| Bit  | 7       | 6 | 5 | 4     | 3      | 2      | 1      | 0      |
|------|---------|---|---|-------|--------|--------|--------|--------|
| Name | ADPGAEN | — | — | PGAIS | SAVRS1 | SAVRS0 | PGAGS1 | PGAGS0 |
| R/W  | R/W     | — | — | R/W   | R/W    | R/W    | R/W    | R/W    |
| POR  | 0       | — | — | 0     | 0      | 0      | 0      | 0      |

- Bit 7 **ADPGAEN**: PGA enable control  
 0: Disable  
 1: Enable
- Bit 6~5 Unimplemented, read as "0"
- Bit 4 **PGAIS**: PGA input voltage selection  
 0: From VREFI pin  
 1: From internal reference voltage V<sub>BGREF</sub>
- Bit 3~2 **SAVRS1~SAVRS0**: A/D converter reference voltage select  
 00: Internal A/D converter power, AV<sub>DD</sub>.  
 01: External VREF pin  
 1x: Internal PGA output voltage, V<sub>R</sub>.

These bits are used to select the A/D converter reference voltage source. When the internal reference voltage source is selected, the reference voltage derived from the external VREF pin will automatically be switched off.

Bit 1~0     **PGAGS1~PGAGS0**: PGA gain select  
 00: Gain=1  
 01: Gain=1.667 –  $V_R=2V$  as  $V_{RI}=1.2V$   
 10: Gain=2.5 –  $V_R=3V$  as  $V_{RI}=1.2V$   
 11: Gain=3.333 –  $V_R=4V$  as  $V_{RI}=1.2V$

These bits are used to select the PGA gain. Note that here the gain is guaranteed only when the PGA input voltage is equal to 1.2V.

• **VBGRC Register**

| Bit  | 7 | 6 | 5 | 4 | 3 | 2 | 1 | 0      |
|------|---|---|---|---|---|---|---|--------|
| Name | — | — | — | — | — | — | — | VBGREN |
| R/W  | — | — | — | — | — | — | — | R/W    |
| POR  | — | — | — | — | — | — | — | 0      |

Bit 7~1     Unimplemented, read as "0"

Bit 0     **VBGREN**: Bandgap reference voltage control  
 0: Disable  
 1: Enable

This bit is used to enable the internal Bandgap reference circuit. The internal Bandgap reference circuit should first be enabled before the  $V_{BGREF}$  voltage is selected to be used. A specific start-up time is necessary for the Bandgap circuit to become stable and accurate.

**A/D Converter Reference Voltage**

The actual reference voltage supply to the A/D Converter can be supplied from the positive power supply pin, AVDD, an external reference source supplied on pin VREF or an internal reference voltage  $V_R$  determined by the SAVRS1~SAVRS0 bits in the SADC2 register. The internal reference voltage is amplified through a programmable gain amplifier, PGA, which is controlled by the ADPGAEN bit in the SADC2 register. The PGA gain can be equal to 1, 1.667, 2.5 or 3.333 and selected using the PGAGS1~PGAGS0 bits in the SADC2 register. The PGA input can come from the external reference input pin, VREFI, or an internal Bandgap reference voltage,  $V_{BGREF}$ , selected by the PGAIS bit in the SADC2 register. As the VREFI and VREF pin both are pin-shared with other functions, when the VREFI or VREF pin is selected as the reference voltage pin, the VREFI or VREF pin-shared function selection bits should first be properly configured to disable other pin-shared functions. However, if the internal reference signal is selected as the reference source, the external reference input from the VREFI or VREF pin will automatically be switched off by hardware.

Note that the internal Bandgap reference circuit should first be enabled before the  $V_{BGREF}$  is selected to be used. A specific start-up time is necessary for the Bandgap circuit to become stable and accurate.

## A/D Converter Input Signals

All of the external A/D analog input pins are pin-shared with the I/O pins as well as other functions. The corresponding pin-shared function selection bits in the PxS1 and PxS0 registers, determine whether the external input pins are setup as A/D converter analog channel inputs or whether they have other functions. If the corresponding pin is setup to be an A/D converter analog channel input, the original pin function will be disabled. In this way, pins can be changed under program control to change their function between A/D inputs and other functions. All pull-high resistors, which are setup through register programming, will be automatically disconnected if the pins are setup as A/D inputs. Note that it is not necessary to first setup the A/D pin as an input in the port control register to enable the A/D input as when the relevant A/D input function selection bits enable an A/D input, the status of the port control register will be overridden.

As these devices contain only one actual analog to digital converter hardware circuit, each of the external and internal analog signals must be routed to the converter. The SAINS3~SAINS0 bits in the SADC1 register are used to determine that the analog signal to be converted comes from the external channel input or internal analog signal. The SACS3~SACS0 bits in the SADC0 register are used to determine which external channel input is selected to be converted. If the SAINS3~SAINS0 bits are set to "0000", the external channel input will be selected to be converted and the SACS3~SACS0 bits can determine which external channel is selected.

When the SAINS field is set to the value of "0x01", "0x10" or "0x11", the internal analog signal will be selected. If the internal analog signal is selected to be converted, the external channel signal input will automatically be switched off regardless of the SACS field value. It will prevent the external channel input from being connected together with the internal analog signal.

| SAINS [3:0]         | SACS [3:0] | Input Signals       | Description   |
|---------------------|------------|---------------------|---|
| 0000,<br>0100, 11xx | 0000~1011  | AN0~AN11            | External channel analog input ANn.                        |
|                     | 11xx       | —                   | Floating, no external channel is selected.                |
| 0001                | xxxx       | AV <sub>DD</sub>    | Internal signal derived from AV <sub>DD</sub>             |
| 0010                | xxxx       | AV <sub>DD</sub> /2 | Internal signal derived from AV <sub>DD</sub> /2          |
| 0011                | xxxx       | AV <sub>DD</sub> /4 | Internal signal derived from AV <sub>DD</sub> /4          |
| 0101                | xxxx       | V <sub>R</sub>      | Internal signal derived from PGA output V <sub>R</sub>    |
| 0110                | xxxx       | V <sub>R</sub> /2   | Internal signal derived from PGA output V <sub>R</sub> /2 |
| 0111                | xxxx       | V <sub>R</sub> /4   | Internal signal derived from PGA output V <sub>R</sub> /4 |
| 10xx                | xxxx       | GND                 | Connected to the ground.                                  |

**A/D Converter Input Signal Selection – HT66F2350**

| SAINS [3:0]         | SACS [3:0] | Input Signals       | Description   |
|---------------------|------------|---------------------|---|
| 0000,<br>0100, 11xx | 0000~1111  | AN0~AN15            | External channel analog input ANn                         |
|                     | xxxx       | —                   | Floating, no external channel is selected.                |
| 0001                | xxxx       | AV <sub>DD</sub>    | Internal signal derived from AV <sub>DD</sub>             |
| 0010                | xxxx       | AV <sub>DD</sub> /2 | Internal signal derived from AV <sub>DD</sub> /2          |
| 0011                | xxxx       | AV <sub>DD</sub> /4 | Internal signal derived from AV <sub>DD</sub> /4          |
| 0101                | xxxx       | V <sub>R</sub>      | Internal signal derived from PGA output V <sub>R</sub>    |
| 0110                | xxxx       | V <sub>R</sub> /2   | Internal signal derived from PGA output V <sub>R</sub> /2 |
| 0111                | xxxx       | V <sub>R</sub> /4   | Internal signal derived from PGA output V <sub>R</sub> /4 |
| 10xx                | xxxx       | GND                 | Connected to the ground.                                  |

**A/D Converter Input Signal Selection – HT66F2360/HT66F2370/HT66F2390**

## A/D Operation

The START bit in the SADC0 register is used to start the AD conversion. When the microcontroller sets this bit from low to high and then low again, an analog to digital conversion cycle will be initiated.

The ADBZ bit in the SADC0 register is used to indicate whether the analog to digital conversion process is in progress or not. This bit will be automatically set to 1 by the microcontroller after an A/D conversion is successfully initiated. When the A/D conversion is complete, the ADBZ bit will be cleared to 0. In addition, the corresponding A/D interrupt request flag will be set in the interrupt control register, and if the interrupts are enabled, an internal interrupt signal will be generated. This A/D internal interrupt signal will direct the program flow to the associated A/D internal interrupt address for processing. If the A/D internal interrupt is disabled, the microcontroller can poll the ADBZ bit in the SADC0 register to check whether it has been cleared as an alternative method of detecting the end of an A/D conversion cycle.

The clock source for the A/D converter, which originates from the system clock  $f_{SYS}$ , can be chosen to be either  $f_{SYS}$  or a subdivided version of  $f_{SYS}$ . The division ratio value is determined by the SACKS2~SACKS0 bits in the SADC1 register. Although the A/D clock source is determined by the system clock  $f_{SYS}$  and by bits SACKS2~SACKS0, there are some limitations on the maximum A/D clock source speed that can be selected. As the recommended range of permissible A/D clock period,  $t_{ADCK}$ , is from 0.5 $\mu$ s to 10 $\mu$ s, care must be taken for system clock frequencies. For example, if the system clock operates at a frequency of 8MHz, the SACKS2~SACKS0 bits should not be set to 000, 001 or 111. Doing so will give A/D clock periods that are less than the minimum A/D clock period which may result in inaccurate A/D conversion values. Refer to the following table for examples, where values marked with an asterisk \* show where, depending upon the device, special care must be taken, as the values may be less than the specified minimum A/D Clock Period.

| $f_{SYS}$ | A/D Clock Period ( $t_{ADCK}$ )     |                                       |                                       |                                       |  |  |  |   |
|-----------|-------------------------------------|---------------------------------------|---------------------------------------|---------------------------------------|--|--|--|---|
|           | SACKS<br>[2:0]=000<br>( $f_{SYS}$ ) | SACKS<br>[2:0]=001<br>( $f_{SYS}/2$ ) | SACKS<br>[2:0]=010<br>( $f_{SYS}/4$ ) | SACKS<br>[2:0]=011<br>( $f_{SYS}/8$ ) | SACKS<br>[2:0]=100<br>( $f_{SYS}/16$ ) | SACKS<br>[2:0]=101<br>( $f_{SYS}/32$ ) | SACKS<br>[2:0]=110<br>( $f_{SYS}/64$ ) | SACKS<br>[2:0]=111<br>( $f_{SYS}/128$ ) |
| 1 MHz     | 1 $\mu$ s                           | 2 $\mu$ s                             | 4 $\mu$ s                             | 8 $\mu$ s                             | 16 $\mu$ s *                           | 32 $\mu$ s *                           | 64 $\mu$ s *                           | 128 $\mu$ s *                           |
| 2 MHz     | 500ns                               | 1 $\mu$ s                             | 2 $\mu$ s                             | 4 $\mu$ s                             | 8 $\mu$ s                              | 16 $\mu$ s *                           | 32 $\mu$ s *                           | 64 $\mu$ s *                            |
| 4 MHz     | 250ns *                             | 500ns                                 | 1 $\mu$ s                             | 2 $\mu$ s                             | 4 $\mu$ s                              | 8 $\mu$ s                              | 16 $\mu$ s *                           | 32 $\mu$ s *                            |
| 8 MHz     | 125ns *                             | 250ns *                               | 500ns                                 | 1 $\mu$ s                             | 2 $\mu$ s                              | 4 $\mu$ s                              | 8 $\mu$ s                              | 16 $\mu$ s *                            |
| 12 MHz    | 83ns *                              | 167ns *                               | 333ns *                               | 667ns                                 | 1.33 $\mu$ s                           | 2.67 $\mu$ s                           | 5.33 $\mu$ s                           | 10.67 $\mu$ s *                         |
| 16 MHz    | 62.5ns *                            | 125ns *                               | 250ns *                               | 500ns                                 | 1 $\mu$ s                              | 2 $\mu$ s                              | 4 $\mu$ s                              | 8 $\mu$ s                               |

### A/D Clock Period Examples

Controlling the power on/off function of the A/D converter circuitry is implemented using the ADCEN bit in the SADC0 register. This bit must be set high to power on the A/D converter. When the ADCEN bit is set high to power on the A/D converter internal circuitry a certain delay, as indicated in the timing diagram, must be allowed before an A/D conversion is initiated. Even if no pins are selected for use as A/D inputs, if the ADCEN bit is high, then some power will still be consumed. In power conscious applications it is therefore recommended that the ADCEN is set low to reduce power consumption when the A/D converter function is not being used.

### Conversion Rate and Timing Diagram

A complete A/D conversion contains two parts, data sampling and data conversion. The data sampling which is defined as  $t_{ADS}$  takes 4 A/D clock cycles and the data conversion takes 12 A/D clock cycles. Therefore a total of 16 A/D clock cycles for an analog signal A/D conversion which is defined as  $t_{ADC}$  are necessary.

$$\text{Maximum single A/D conversion rate} = \text{A/D clock period} \times 16$$

The accompanying diagram shows graphically the various stages involved in an external channel input signal analog to digital conversion process and its associated timing. After an A/D conversion process has been initiated by the application program, the microcontroller internal hardware will begin to carry out the conversion, during which time the program can continue with other functions. The time taken for the A/D conversion is 16  $t_{ADCK}$  clock cycles where  $t_{ADCK}$  is equal to the A/D clock period.

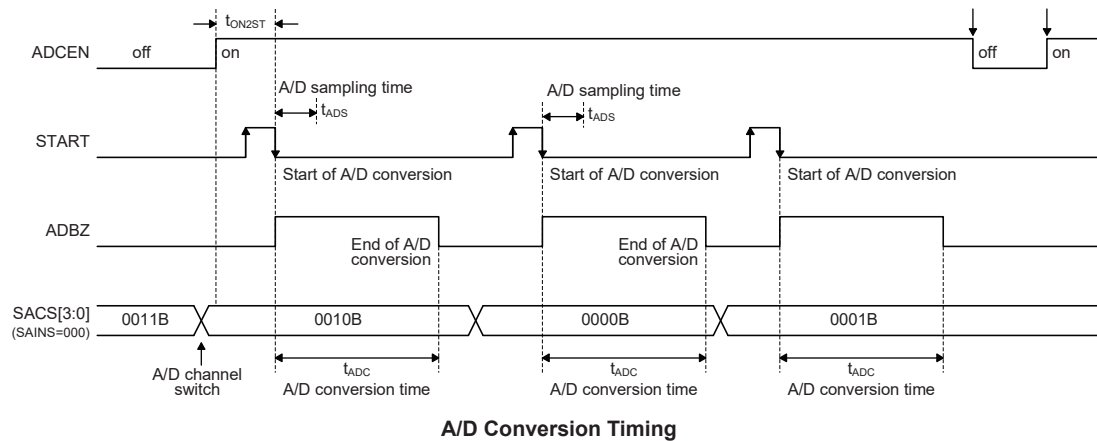

## Summary of A/D Conversion Steps

The following summarises the individual steps that should be executed in order to implement an A/D conversion process.

- Step 1  
Select the required A/D conversion clock by properly programming the SACKS2~SACKS0 bits in the SADC1 register.
- Step 2  
Enable the A/D converter by setting the ADCEN bit in the SADC0 register to one.
- Step 3  
Select which signal is to be connected to the internal A/D converter by correctly configuring the SACS and SAINS bit fields  
Selecting the external channel input to be converted, go to Step 4.  
Selecting the internal analog signal to be converted, go to Step 5.
- Step 4  
If the SAINS field is 0000, 0100 or 11xx, the external channel input can be selected. The desired external channel input is selected by configuring the SACS field. When the A/D input signal comes from the external channel input, the corresponding pin should be configured as an A/D input function by selecting the relevant pin-shared function control bits. Then go to Step 6.
- Step 5  
If the SAINS field is set to 0x01, 0x10 or 0x11, the relevant internal analog signal will be selected. When the internal analog signal is selected to be converted, the external channel analog input will automatically be disconnected. Then go to Step 6.
- Step 6  
Select the A/D converter output data format by configuring the ADRFS bit.
- Step 7  
Select the A/D converter reference voltage source by configuring the SAVRS bit field.  
Select the PGA input signal and the desired PGA gain if the PGA output voltage,  $V_R$ , is selected as the A/D converter reference voltage.
- Step 8  
If A/D conversion interrupt is used, the interrupt control registers must be correctly configured to ensure the A/D interrupt function is active. The master interrupt control bit, EMI, and the A/D conversion interrupt control bit, ADE, must both be set high in advance.
- Step 9  
The A/D conversion procedure can now be initialized by setting the START bit from low to high and then low again.
- Step 10  
If A/D conversion is in progress, the ADBZ flag will be set high. After the A/D conversion process is complete, the ADBZ flag will go low and then the output data can be read from SADOH and SADOL registers.

Note: When checking for the end of the conversion process, if the method of polling the ADBZ bit in the SADC0 register is used, the interrupt enable step above can be omitted.

## Programming Considerations

During microcontroller operations where the A/D converter is not being used, the A/D internal circuitry can be switched off to reduce power consumption, by setting bit ADCEN low in the SADC0 register. When this happens, the internal A/D converter circuits will not consume power irrespective of what analog voltage is applied to their input lines. If the A/D converter input lines are used as normal I/Os, then care must be taken as if the input voltage is not at a valid logic level, then this may lead to some increase in power consumption.

## A/D Transfer Function

As the devices contain a 12-bit A/D converter, its full-scale converted digitised value is equal to FFFH. Since the full-scale analog input value is equal to the actual A/D converter reference voltage,  $V_{REF}$ , this gives a single bit analog input value of reference voltage value divided by 4096.

$$1 \text{ LSB} = V_{REF} \div 4096$$

The A/D Converter input voltage value can be calculated using the following equation:

$$\text{A/D input voltage} = \text{A/D output digital value} \times V_{REF} \div 4096$$

The diagram shows the ideal transfer function between the analog input value and the digitised output value for the A/D converter. Except for the digitised zero value, the subsequent digitised values will change at a point 0.5 LSB below where they would change without the offset, and the last full scale digitised value will change at a point 1.5 LSB below the  $V_{REF}$  level.

Note that here the  $V_{REF}$  voltage is the actual A/D converter reference voltage determined by the SAVRS field.

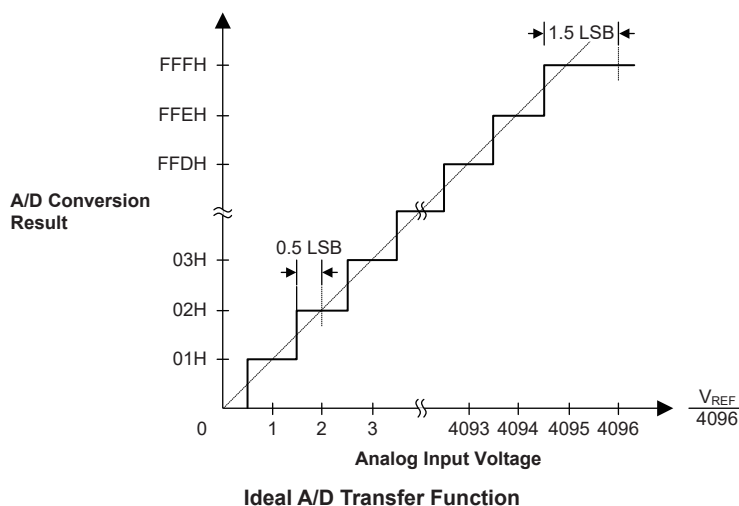

## A/D Programming Examples

The following two programming examples illustrate how to setup and implement an A/D conversion. In the first example, the method of polling the ADBZ bit in the SADC0 register is used to detect when the conversion cycle is complete, whereas in the second example, the A/D interrupt is used to determine when the conversion is complete.

### Example: using an ADBZ polling method to detect the end of conversion

```
clr ADE                ; disable ADC interrupt
mov a,03H              ; select fsys/8 as A/D clock and A/D input
mov SADC1,a           ; signal comes from external channel
mov a,00H              ; select AVDD as the A/D reference voltage source
mov SADC2,a
set ADCEN
mov a,03H              ; setup PCS0 to configure pin AN0
mov PCS0,a
mov a,00H              ; select AN0 as the A/D external channel input
mov SADC0,a
:
start_conversion:
clr START              ; high pulse on start bit to initiate conversion
set START              ; reset A/D
clr START              ; start A/D
:
polling_EOC:
sz ADBZ                ; poll the SADC0 register ADBZ bit to detect end of A/D conversion
jmp polling_EOC        ; continue polling
:
mov a,SADOL             ; read low byte conversion result value
mov SADOL_buffer,a    ; save result to user defined register
mov a,SADOH             ; read high byte conversion result value
mov SADOH_buffer,a    ; save result to user defined register
:
jmp start_conversion   ; start next A/D conversion
```

**Example: using the interrupt method to detect the end of conversion**

```
clr ADE ; disable ADC interrupt
mov a,03H ; select fsys/8 as A/D clock and A/D input
mov SADC1,a ; signal comes from external channel
mov a,00H ; select AVDD as the A/D reference voltage source
mov SADC2,a
set ADCEN
mov a,03h ; setup PCS0 to configure pin AN0
mov PCS0,a
mov a,00h
mov SADC0,a ; select AN0 as the A/D external channel input
:
Start_conversion:
clr START ; high pulse on START bit to initiate conversion
set START ; reset A/D
clr START ; start A/D
clr ADF ; clear ADC interrupt request flag
set ADE ; enable ADC interrupt
set EMI ; enable global interrupt
:
:
ADC_ISR: ; ADC interrupt service routine
mov acc_stack,a ; save ACC to user defined memory
mov a,STATUS
mov status_stack,a ; save STATUS to user defined memory
:
mov a,SADOL ; read low byte conversion result value
mov SADOL_buffer,a ; save result to user defined register
mov a,SADOH ; read high byte conversion result value
mov SADOH_buffer,a ; save result to user defined register
:
EXIT_INT_ISR:
mov a,status_stack
mov STATUS,a ; restore STATUS from user defined memory
mov a,acc_stack ; restore ACC from user defined memory
reti
```

## Serial Interface Module – SIM

These devices contain a Serial Interface Module, which includes both the four-line SPI interface or two-line I<sup>2</sup>C interface types, to allow an easy method of communication with external peripheral hardware. Having relatively simple communication protocols, these serial interface types allow the microcontroller to interface to external SPI or I<sup>2</sup>C based hardware such as sensors, Flash or EEPROM memory, etc. The SIM interface pins are pin-shared with other I/O pins and therefore the SIM interface functional pins must first be selected using the corresponding pin-shared function selection bits. As both interface types share the same pins and registers, the choice of whether the SPI or I<sup>2</sup>C type is used is made using the SIM operating mode control bits, named SIM2~SIM0, in the SIMC0 register. These pull-high resistors of the SIM pin-shared I/O pins are selected using pull-high control registers when the SIM function is enabled and the corresponding pins are used as SIM input pins.

### SPI Interface

The SPI interface is often used to communicate with external peripheral devices such as sensors, Flash or EEPROM memory devices, etc. Originally developed by Motorola, the four line SPI interface is a synchronous serial data interface that has a relatively simple communication protocol simplifying the programming requirements when communicating with external hardware devices.

The communication is full duplex and operates as a slave/master type, where the devices can be either master or slave. Although the SPI interface specification can control multiple slave devices from a single master, these devices provided only one  $\overline{\text{SCS}}$  pin. If the master needs to control multiple slave devices from a single master, the master can use I/O pin to select the slave devices.

### SPI Interface Operation

The SPI interface is a full duplex synchronous serial data link. It is a four line interface with pin names SDI, SDO, SCK and  $\overline{\text{SCS}}$ . Pins SDI and SDO are the Serial Data Input and Serial Data Output lines, SCK is the Serial Clock line and  $\overline{\text{SCS}}$  is the Slave Select line. As the SPI interface pins are pin-shared with normal I/O pins and with the I<sup>2</sup>C function pins, the SPI interface pins must first be selected by configuring the pin-shared function selection bits and setting the correct bits in the SIMC0 and SIMC2 registers. After the desired SPI configuration has been set it can be disabled or enabled using the SIMEN bit in the SIMC0 register. Communication between devices connected to the SPI interface is carried out in a slave/master mode with all data transfer initiations being implemented by the master. The Master also controls the clock signal. As the device only contains a single  $\overline{\text{SCS}}$  pin only one slave device can be utilized. The  $\overline{\text{SCS}}$  pin is controlled by software, set CSEN bit to 1 to enable  $\overline{\text{SCS}}$  pin function, set CSEN bit to 0 the  $\overline{\text{SCS}}$  pin will be floating state.

The SPI function in this device offers the following features:

- Full duplex synchronous data transfer
- Both Master and Slave modes
- LSB first or MSB first data transmission modes
- Transmission complete flag
- Rising or falling active clock edge

The status of the SPI interface pins is determined by a number of factors such as whether the device is in the master or slave mode and upon the condition of certain control bits such as CSEN and SIMEN.

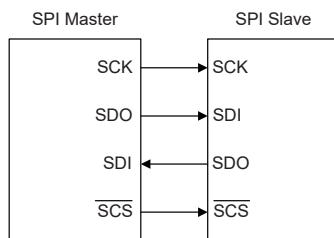

SPI Master/Slave Connection

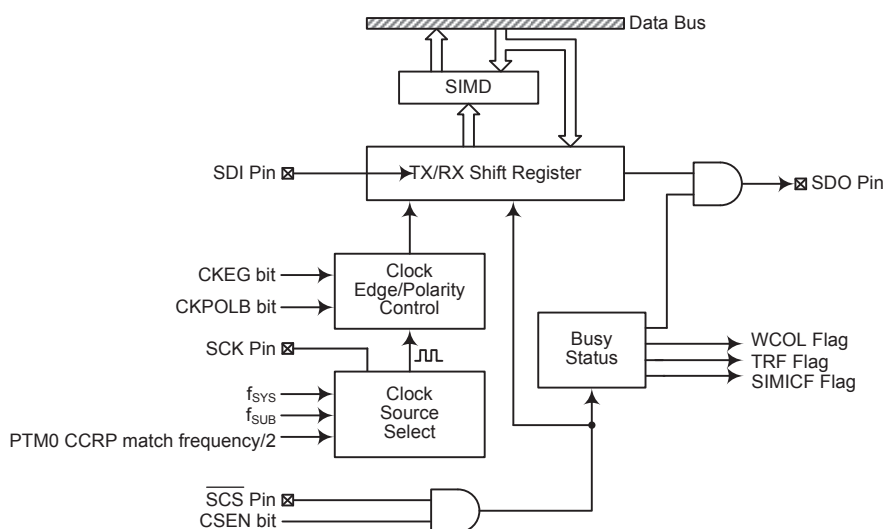

SPI Block Diagram

### SPI Registers

There are three internal registers which control the overall operation of the SPI interface. These are the SIMD data register and two registers SIMC0 and SIMC2. Note that the SIMC1 register is only used by the I<sup>2</sup>C interface.

| Register Name | Bit  |      |        |      |         |         |       |        |
|---------------|------|------|--------|------|---------|---------|-------|--------|
|               | 7    | 6    | 5      | 4    | 3       | 2       | 1     | 0      |
| SIMC0         | SIM2 | SIM1 | SIM0   | —    | SIMDEB1 | SIMDEB0 | SIMEN | SIMICF |
| SIMC2         | D7   | D6   | CKPOLB | CKEG | MLS     | CSEN    | WCOL  | TRF    |
| SIMD          | D7   | D6   | D5     | D4   | D3      | D2      | D1    | D0     |

SPI Registers List

#### • SIMD Register

The SIMD register is used to store the data being transmitted and received. The same register is used by both the SPI and I<sup>2</sup>C functions. Before the device writes data to the SPI bus, the actual data to be transmitted must be placed in the SIMD register. After the data is received from the SPI bus, the device can read it from the SIMD register. Any transmission or reception of data from the SPI bus must be made via the SIMD register.

| Bit  | 7   | 6   | 5   | 4   | 3   | 2   | 1   | 0   |
|------|-----|-----|-----|-----|-----|-----|-----|-----|
| Name | D7  | D6  | D5  | D4  | D3  | D2  | D1  | D0  |
| R/W  | R/W | R/W | R/W | R/W | R/W | R/W | R/W | R/W |
| POR  | x   | x   | x   | x   | x   | x   | x   | x   |

"x": unknown

There are also two control registers for the SPI interface, SIMC0 and SIMC2. Note that the SIMC2 register also has the name SIMA which is used by the I<sup>2</sup>C function. The SIMC1 register is not used by the SPI function, only by the I<sup>2</sup>C function. Register SIMC0 is used to control the enable/disable function and to set the data transmission clock frequency. Register SIMC2 is used for other control functions such as LSB/MSB selection, write collision flag, etc.

• **SIMC0 Register**

| Bit  | 7    | 6    | 5    | 4 | 3       | 2       | 1     | 0      |
|------|------|------|------|---|---------|---------|-------|--------|
| Name | SIM2 | SIM1 | SIM0 | — | SIMDEB1 | SIMDEB0 | SIMEN | SIMICF |
| R/W  | R/W  | R/W  | R/W  | — | R/W     | R/W     | R/W   | R/W    |
| POR  | 1    | 1    | 1    | — | 0       | 0       | 0     | 0      |

Bit 7~5 **SIM2~SIM0**: SIM Operating Mode Control  
 000: SPI master mode; SPI clock is  $f_{SYS} / 4$   
 001: SPI master mode; SPI clock is  $f_{SYS} / 16$   
 010: SPI master mode; SPI clock is  $f_{SYS} / 64$   
 011: SPI master mode; SPI clock is  $f_{SUB}$   
 100: SPI master mode; SPI clock is PTM0 CCRP match frequency/2  
 101: SPI slave mode  
 110: I<sup>2</sup>C slave mode  
 111: Non SIM function

These bits setup the overall operating mode of the SIM function. As well as selecting if the I<sup>2</sup>C or SPI function, they are used to control the SPI Master/Slave selection and the SPI Master clock frequency. The SPI clock is a function of the system clock but can also be chosen to be sourced from PTM0. If the SPI Slave Mode is selected then the clock will be supplied by an external Master device.

Bit 4 Unimplemented, read as "0"

Bit 3~2 **SIMDEB1~SIMDEB0**: I<sup>2</sup>C Debounce Time Selection

The SIMDEB1~SIMDEB0 bits are only used in the I<sup>2</sup>C mode and the detailed definition is described in the I<sup>2</sup>C section.

Bit 1 **SIMEN**: SIM Enable Control

- 0: Disable
- 1: Enable

The bit is the overall on/off control for the SIM interface. When the SIMEN bit is cleared to zero to disable the SIM interface, the SDI, SDO, SCK and SCS, or SDA and SCL lines will lose their SPI or I<sup>2</sup>C function and the SIM operating current will be reduced to a minimum value. When the bit is high the SIM interface is enabled. The SIM configuration option must have first enabled the SIM interface for this bit to be effective. If the SIM is configured to operate as an SPI interface via the SIM2~SIM0 bits, the contents of the SPI control registers will remain at the previous settings when the SIMEN bit changes from low to high and should therefore be first initialised by the application program. If the SIM is configured to operate as an I<sup>2</sup>C interface via the SIM2~SIM0 bits and the SIMEN bit changes from low to high, the contents of the I<sup>2</sup>C control bits such as HTX and TXAK will remain at the previous settings and should therefore be first initialised by the application program while the relevant I<sup>2</sup>C flags such as HCF, HAAS, HBB, SRW and RXAK will be set to their default states.

Bit 0 **SIMICF**: SIM SPI slave mode Incomplete Transfer Flag

- 0: SIM SPI slave mode incomplete condition not occurred
- 1: SIM SPI slave mode incomplete condition occurred

This bit is only available when the SIM is configured to operate in an SPI slave mode. If the SPI operates in the slave mode with the SIMEN and CSEN bits both being set to 1 but the  $\overline{SCS}$  line is pulled high by the external master device before the SPI data transfer is completely finished, the SIMICF bit will be set to 1 together with the TRF bit. When this condition occurs, the corresponding interrupt will occur if the interrupt function is enabled. However, the TRF bit will not be set to 1 if the SIMICF bit is set to 1 by software application program.

• **SIMC2 Register**

| Bit  | 7   | 6   | 5      | 4    | 3   | 2    | 1    | 0   |
|------|-----|-----|--------|------|-----|------|------|-----|
| Name | D7  | D6  | CKPOLB | CKEG | MLS | CSEN | WCOL | TRF |
| R/W  | R/W | R/W | R/W    | R/W  | R/W | R/W  | R/W  | R/W |
| POR  | 0   | 0   | 0      | 0    | 0   | 0    | 0    | 0   |

- Bit 7~6      **Undefined bits**  
 These bits can be read or written by the application program.
- Bit 5      **CKPOLB: SPI clock line base condition selection**  
 0: The SCK line will be high when the clock is inactive.  
 1: The SCK line will be low when the clock is inactive.  
 The CKPOLB bit determines the base condition of the clock line, if the bit is high, then the SCK line will be low when the clock is inactive. When the CKPOLB bit is low, then the SCK line will be high when the clock is inactive.
- Bit 4      **CKEG: SPI SCK clock active edge type selection**  
 CKPOLB=0  
 0: SCK is high base level and data capture at SCK rising edge  
 1: SCK is high base level and data capture at SCK falling edge  
 CKPOLB=1  
 0: SCK is low base level and data capture at SCK falling edge  
 1: SCK is low base level and data capture at SCK rising edge  
 The CKEG and CKPOLB bits are used to setup the way that the clock signal outputs and inputs data on the SPI bus. These two bits must be configured before data transfer is executed otherwise an erroneous clock edge may be generated. The CKPOLB bit determines the base condition of the clock line, if the bit is high, then the SCK line will be low when the clock is inactive. When the CKPOLB bit is low, then the SCK line will be high when the clock is inactive. The CKEG bit determines active clock edge type which depends upon the condition of CKPOLB bit.
- Bit 3      **MLS: SPI data shift order**  
 0: LSB first  
 1: MSB first  
 This is the data shift select bit and is used to select how the data is transferred, either MSB or LSB first. Setting the bit high will select MSB first and low for LSB first.
- Bit 2      **CSEN: SPI  $\overline{SCS}$  pin control**  
 0: Disable  
 1: Enable  
 The CSEN bit is used as an enable/disable for the  $\overline{SCS}$  pin. If this bit is low, then the  $\overline{SCS}$  pin will be disabled and placed into I/O pin or other pin-shared functions. If the bit is high, the  $\overline{SCS}$  pin will be enabled and used as a select pin.
- Bit 1      **WCOL: SPI write collision flag**  
 0: No collision  
 1: Collision  
 The WCOL flag is used to detect whether a data collision has occurred or not. If this bit is high, it means that data has been attempted to be written to the SIMD register during a data transfer operation. This writing operation will be ignored if data is being transferred. This bit can be cleared by the application program.
- Bit 0      **TRF: SPI Transmit/Receive complete flag**  
 0: SPI data is being transferred  
 1: SPI data transfer is completed  
 The TRF bit is the Transmit/Receive Complete flag and is set to 1 automatically when an SPI data transfer is completed, but must cleared to 0 by the application program. It can be used to generate an interrupt.

### SPI Communication

After the SPI interface is enabled by setting the SIMEN bit high, then in the Master Mode, when data is written to the SIMD register, transmission/reception will begin simultaneously. When the data transfer is complete, the TRF flag will be set automatically, but must be cleared using the application program. In the Slave Mode, when the clock signal from the master has been received, any data in the SIMD register will be transmitted and any data on the SDI pin will be shifted into the SIMD register. The master should output a  $\overline{SCS}$  signal to enable the slave devices before a clock signal is provided. The slave data to be transferred should be well prepared at the appropriate moment relative to the  $\overline{SCS}$  signal depending upon the configurations of the CKPOLB bit and CKEG bit. The accompanying timing diagram shows the relationship between the slave data and  $\overline{SCS}$  signal for various configurations of the CKPOLB and CKEG bits.

The SPI will continue to function even in the IDLE Mode.

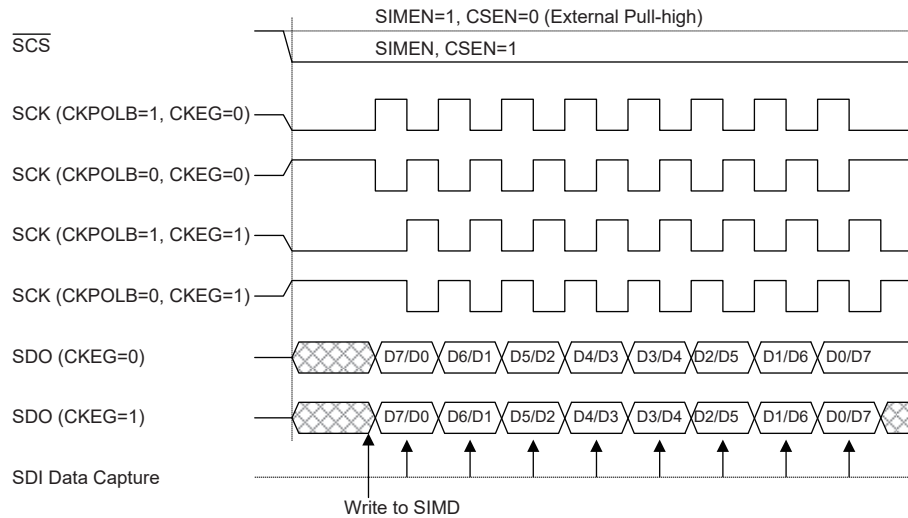

**SPI Master Mode Timing**

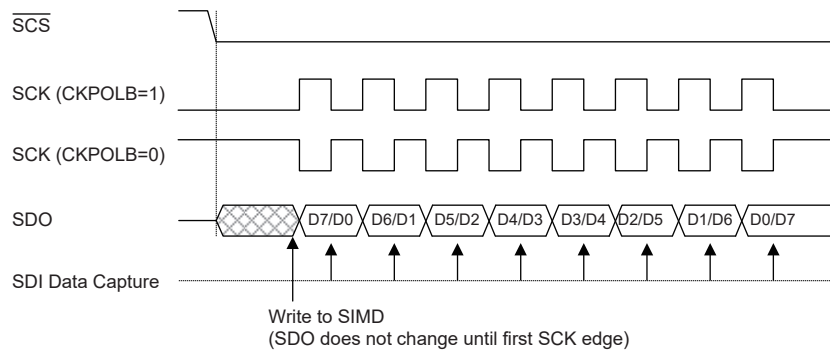

**SPI Slave Mode Timing – CKEG=0**

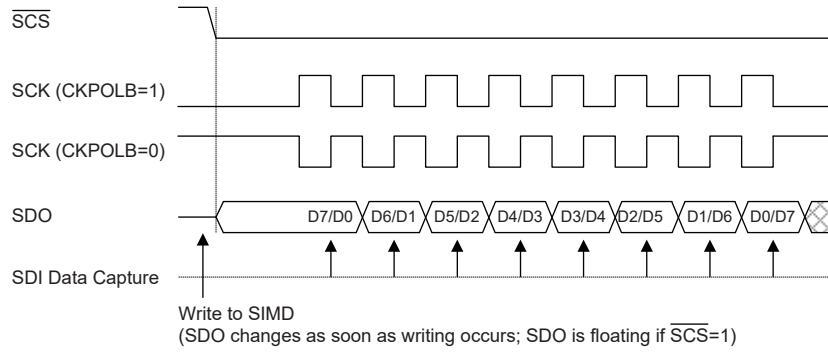

Note: For SPI slave mode, if SIMEN=1 and CSEN=0, SPI is always enabled and ignores the  $\overline{SCS}$  level.

**SPI Slave Mode Timing – CKEG=1**

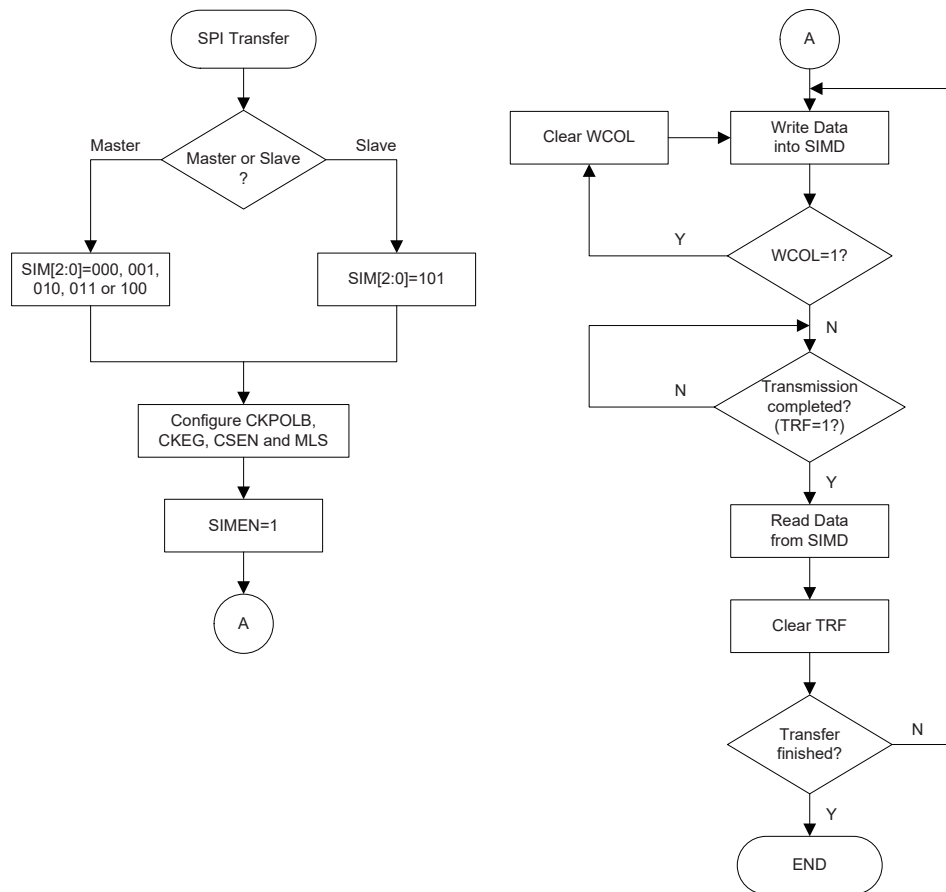

**SPI Transfer Control Flow Chart**

## I<sup>2</sup>C Interface

The I<sup>2</sup>C interface is used to communicate with external peripheral devices such as sensors, EEPROM memory etc. Originally developed by Philips, it is a two line low speed serial interface for synchronous serial data transfer. The advantage of only two lines for communication, relatively simple communication protocol and the ability to accommodate multiple devices on the same bus has made it an extremely popular interface type for many applications.

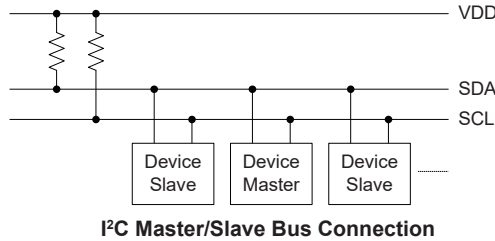

### I<sup>2</sup>C interface Operation

The I<sup>2</sup>C serial interface is a two line interface, a serial data line, SDA, and serial clock line, SCL. As many devices may be connected together on the same bus, their outputs are both open drain types. For this reason it is necessary that external pull-high resistors are connected to these outputs. Note that no chip select line exists, as each device on the I<sup>2</sup>C bus is identified by a unique address which will be transmitted and received on the I<sup>2</sup>C bus.

When two devices communicate with each other on the bidirectional I<sup>2</sup>C bus, one is known as the master device and one as the slave device. Both master and slave can transmit and receive data; however, it is the master device that has overall control of the bus. For these devices, which only operate in slave mode, there are two methods of transferring data on the I<sup>2</sup>C bus, the slave transmit mode and the slave receive mode.

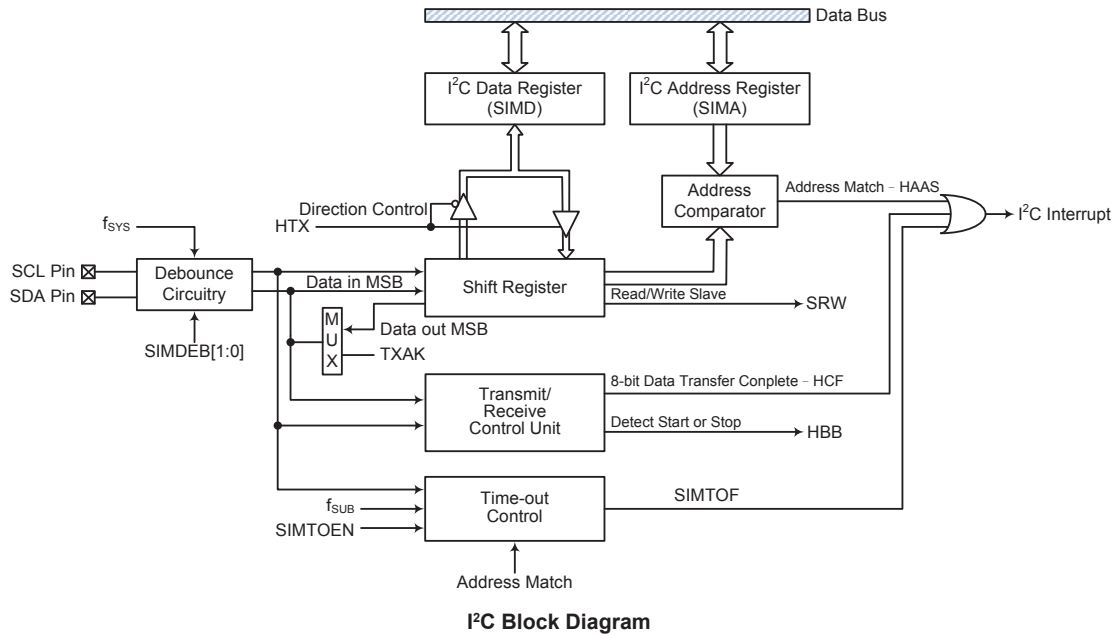

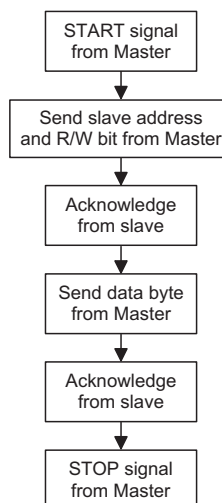

The SIMDEB1 and SIMDEB0 bits determine the debounce time of the I<sup>2</sup>C interface. This uses the system clock to in effect add a debounce time to the external clock to reduce the possibility of glitches on the clock line causing erroneous operation. The debounce time, if selected, can be chosen to be either 2 or 4 system clocks. To achieve the required I<sup>2</sup>C data transfer speed, there exists a relationship between the system clock,  $f_{\text{SYS}}$ , and the I<sup>2</sup>C debounce time. For either the I<sup>2</sup>C Standard or Fast mode operation, users must take care of the selected system clock frequency and the configured debounce time to match the criterion shown in the following table.

| I <sup>2</sup> C Debounce Time Selection | I <sup>2</sup> C Standard Mode (100kHz) | I <sup>2</sup> C Fast Mode (400kHz) |
|--|---|-------------------------------------|
| No Debounce                              | $f_{\text{SYS}} > 2 \text{ MHz}$        | $f_{\text{SYS}} > 5 \text{ MHz}$    |
| 2 system clock debounce                  | $f_{\text{SYS}} > 4 \text{ MHz}$        | $f_{\text{SYS}} > 10 \text{ MHz}$   |
| 4 system clock debounce                  | $f_{\text{SYS}} > 8 \text{ MHz}$        | $f_{\text{SYS}} > 20 \text{ MHz}$   |

**I<sup>2</sup>C Minimum  $f_{\text{SYS}}$  Frequency**

### I<sup>2</sup>C Registers

There are three control registers associated with the I<sup>2</sup>C bus, SIMC0, SIMC1 and SIMA, and one data register, SIMD. The SIMD register, which is shown in the above SPI section, is used to store the data being transmitted and received on the I<sup>2</sup>C bus. Before the microcontroller writes data to the I<sup>2</sup>C bus, the actual data to be transmitted must be placed in the SIMD register. After the data is received from the I<sup>2</sup>C bus, the microcontroller can read it from the SIMD register. Any transmission or reception of data from the I<sup>2</sup>C bus must be made via the SIMD register.

Note that the SIMA register also has the name SIMC2 which is used by the SPI function. Bit SIMEN and bits SIM2~SIM0 in register SIMC0 are used by the I<sup>2</sup>C interface.

| Register Name | Bit     |        |         |         |         |         |         |         |
|---------------|---------|--------|---------|---------|---------|---------|---------|---------|
|               | 7       | 6      | 5       | 4       | 3       | 2       | 1       | 0       |
| SIMC0         | SIM2    | SIM1   | SIM0    | —       | SIMDEB1 | SIMDEB0 | SIMEN   | SIMICF  |
| SIMC1         | HCF     | HAAS   | HBB     | HTX     | TXAK    | SRW     | IAMWU   | RXAK    |
| SIMA          | IICA6   | IICA5  | IICA4   | IICA3   | IICA2   | IICA1   | IICA0   | —       |
| SIMD          | D7      | D6     | D5      | D4      | D3      | D2      | D1      | D0      |
| SIMTOC        | SIMTOEN | SIMTOF | SIMTOS5 | SIMTOS4 | SIMTOS3 | SIMTOS2 | SIMTOS1 | SIMTOS0 |

**I<sup>2</sup>C Registers List**

• **SIMD Register**

The SIMD register is used to store the data being transmitted and received. The same register is used by both the SPI and I<sup>2</sup>C functions. Before the device writes data to the I<sup>2</sup>C bus, the actual data to be transmitted must be placed in the SIMD register. After the data is received from the I<sup>2</sup>C bus, the device can read it from the SIMD register. Any transmission or reception of data from the I<sup>2</sup>C bus must be made via the SIMD register.

| Bit  | 7   | 6   | 5   | 4   | 3   | 2   | 1   | 0   |
|------|-----|-----|-----|-----|-----|-----|-----|-----|
| Name | D7  | D6  | D5  | D4  | D3  | D2  | D1  | D0  |
| R/W  | R/W | R/W | R/W | R/W | R/W | R/W | R/W | R/W |
| POR  | x   | x   | x   | x   | x   | x   | x   | x   |

"x": unknown

• **SIMA Register**

The SIMA register is also used by the SPI interface but has the name SIMC2. The SIMA register is the location where the 7-bit slave address of the slave device is stored. Bits 7~1 of the SIMA register define the device slave address. Bit 0 is not implemented.

When a master device, which is connected to the I<sup>2</sup>C bus, sends out an address, which matches the slave address in the SIMA register, the slave device will be selected. Note that the SIMA register is the same register address as SIMC2 which is used by the SPI interface.

| Bit  | 7     | 6     | 5     | 4     | 3     | 2     | 1     | 0 |
|------|-------|-------|-------|-------|-------|-------|-------|---|
| Name | IICA6 | IICA5 | IICA4 | IICA3 | IICA2 | IICA1 | IICA0 | — |
| R/W  | R/W   | R/W   | R/W   | R/W   | R/W   | R/W   | R/W   | — |
| POR  | x     | x     | x     | x     | x     | x     | x     | — |

"x": unknown

Bit 7~1     **IICA6~IICA0**: I<sup>2</sup>C slave address  
IICA6~IICA0 is the I<sup>2</sup>C slave address bit 6 ~ bit 0

Bit 0        Unimplemented, read as "0"

There are also two control registers for the I<sup>2</sup>C interface, SIMC0 and SIMC1. The register SIMC0 is used to control the enable/disable function and to set the data transmission clock frequency. The SIMC1 register contains the relevant flags which are used to indicate the I<sup>2</sup>C communication status.

• **SIMC0 Register**

| Bit  | 7    | 6    | 5    | 4 | 3       | 2       | 1     | 0      |
|------|------|------|------|---|---------|---------|-------|--------|
| Name | SIM2 | SIM1 | SIM0 | — | SIMDEB1 | SIMDEB0 | SIMEN | SIMICF |
| R/W  | R/W  | R/W  | R/W  | — | R/W     | R/W     | R/W   | R/W    |
| POR  | 1    | 1    | 1    | — | 0       | 0       | 0     | 0      |

Bit 7~5     **SIM2~SIM0**: SIM Operating Mode Control  
000: SPI master mode; SPI clock is  $f_{SYS} / 4$   
001: SPI master mode; SPI clock is  $f_{SYS} / 16$   
010: SPI master mode; SPI clock is  $f_{SYS} / 64$   
011: SPI master mode; SPI clock is  $f_{SUB}$   
100: SPI master mode; SPI clock is PTM0 CCRP match frequency/2  
101: SPI slave mode  
110: I<sup>2</sup>C slave mode  
111: Non SIM function

These bits setup the overall operating mode of the SIM function. As well as selecting if the I<sup>2</sup>C or SPI function, they are used to control the SPI Master/Slave selection and the SPI Master clock frequency. The SPI clock is a function of the system clock but can also be chosen to be sourced from PTM0. If the SPI Slave Mode is selected then the clock will be supplied by an external Master device.

- Bit 4 Unimplemented, read as "0"
- Bit 3~2 **SIMDEB1~SIMDEB0**: I<sup>2</sup>C Debounce Time Selection  
 00: No debounce  
 01: 2 system clock debounce  
 1x: 4 system clock debounce  
 These bits are used to select the I<sup>2</sup>C debounce time when the SIM is configured as the I<sup>2</sup>C interface function by setting the SIM2~SIM0 bits to "110".
- Bit 1 **SIMEN**: SIM Enable Control  
 0: Disable  
 1: Enable  
 The bit is the overall on/off control for the SIM interface. When the SIMEN bit is cleared to zero to disable the SIM interface, the SDI, SDO, SCK and SCS, or SDA and SCL lines will lose their SPI or I<sup>2</sup>C function and the SIM operating current will be reduced to a minimum value. When the bit is high the SIM interface is enabled. The SIM configuration option must have first enabled the SIM interface for this bit to be effective. If the SIM is configured to operate as an SPI interface via the SIM2~SIM0 bits, the contents of the SPI control registers will remain at the previous settings when the SIMEN bit changes from low to high and should therefore be first initialised by the application program. If the SIM is configured to operate as an I<sup>2</sup>C interface via the SIM2~SIM0 bits and the SIMEN bit changes from low to high, the contents of the I<sup>2</sup>C control bits such as HTX and TXAK will remain at the previous settings and should therefore be first initialised by the application program while the relevant I<sup>2</sup>C flags such as HCF, HAAS, HBB, SRW and RXAK will be set to their default states.
- Bit 0 **SIMICF**: SIM SPI Incomplete Flag  
 The SIMICF bit is only used in the SPI mode and the detailed definition is described in the SPI section.

• **SIMC1 Register**

| Bit  | 7   | 6    | 5   | 4   | 3    | 2   | 1     | 0    |
|------|-----|------|-----|-----|------|-----|-------|------|
| Name | HCF | HAAS | HBB | HTX | TXAK | SRW | IAMWU | RXAK |
| R/W  | R   | R    | R   | R/W | R/W  | R/W | R/W   | R    |
| POR  | 1   | 0    | 0   | 0   | 0    | 0   | 0     | 1    |

- Bit 7 **HCF**: I<sup>2</sup>C Bus data transfer completion flag  
 0: Data is being transferred  
 1: Completion of an 8-bit data transfer  
 The HCF flag is the data transfer flag. This flag will be zero when data is being transferred. Upon completion of an 8-bit data transfer the flag will go high and an interrupt will be generated.
- Bit 6 **HAAS**: I<sup>2</sup>C Bus address match flag  
 0: Not address match  
 1: Address match  
 The HAAS flag is the address match flag. This flag is used to determine if the slave device address is the same as the master transmit address. If the addresses match then this bit will be high, if there is no match then the flag will be low.
- Bit 5 **HBB**: I<sup>2</sup>C Bus busy flag  
 0: I<sup>2</sup>C Bus is not busy  
 1: I<sup>2</sup>C Bus is busy  
 The HBB flag is the I<sup>2</sup>C busy flag. This flag will be "1" when the I<sup>2</sup>C bus is busy which will occur when a START signal is detected. The flag will be set to "0" when the bus is free which will occur when a STOP signal is detected.
- Bit 4 **HTX**: I<sup>2</sup>C slave device transmitter/receiver selection  
 0: Slave device is the receiver  
 1: Slave device is the transmitter

- Bit 3      **TXAK:** I<sup>2</sup>C bus transmit acknowledge flag  
            0: Slave send acknowledge flag  
            1: Slave does not send acknowledge flag  
The TXAK bit is the transmit acknowledge flag. After the slave device receipt of 8-bits of data, this bit will be transmitted to the bus on the 9<sup>th</sup> clock from the slave device. The slave device must always set TXAK bit to "0" before further data is received.
- Bit 2      **SRW:** I<sup>2</sup>C slave read/write flag  
            0: Slave device should be in receive mode  
            1: Slave device should be in transmit mode  
The SRW flag is the I<sup>2</sup>C Slave Read/Write flag. This flag determines whether the master device wishes to transmit or receive data from the I<sup>2</sup>C bus. When the transmitted address and slave address is match, that is when the HAAS flag is set high, the slave device will check the SRW flag to determine whether it should be in transmit mode or receive mode. If the SRW flag is high, the master is requesting to read data from the bus, so the slave device should be in transmit mode. When the SRW flag is zero, the master will write data to the bus, therefore the slave device should be in receive mode to read this data.
- Bit 1      **IAMWU:** I<sup>2</sup>C Address Match Wake-Up control  
            0: Disable  
            1: Enable – must be cleared by the application program after wake-up  
This bit should be set to 1 to enable the I<sup>2</sup>C address match wake up from the SLEEP or IDLE Mode. If the IAMWU bit has been set before entering either the SLEEP or IDLE mode to enable the I<sup>2</sup>C address match wake up, then this bit must be cleared by the application program after wake-up to ensure correction device operation.
- Bit 0      **RXAK:** I<sup>2</sup>C bus receive acknowledge flag  
            0: Slave receives acknowledge flag  
            1: Slave does not receive acknowledge flag  
The RXAK flag is the receiver acknowledge flag. When the RXAK flag is "0", it means that a acknowledge signal has been received at the 9<sup>th</sup> clock, after 8 bits of data have been transmitted. When the slave device in the transmit mode, the slave device checks the RXAK flag to determine if the master receiver wishes to receive the next byte. The slave transmitter will therefore continue sending out data until the RXAK flag is "1". When this occurs, the slave transmitter will release the SDA line to allow the master to send a STOP signal to release the I<sup>2</sup>C Bus.

### I<sup>2</sup>C Bus Communication

Communication on the I<sup>2</sup>C bus requires four separate steps, a START signal, a slave device address transmission, a data transmission and finally a STOP signal. When a START signal is placed on the I<sup>2</sup>C bus, all devices on the bus will receive this signal and be notified of the imminent arrival of data on the bus. The first seven bits of the data will be the slave address with the first bit being the MSB. If the address of the slave device matches that of the transmitted address, the HAAS bit in the SIMC1 register will be set and an I<sup>2</sup>C interrupt will be generated. After entering the interrupt service routine, the slave device must first check the condition of the HAAS and SIMTOF bits to determine whether the interrupt source originates from an address match, 8-bit data transfer completion or I<sup>2</sup>C bus time-out occurrence. During a data transfer, note that after the 7-bit slave address has been transmitted, the following bit, which is the 8<sup>th</sup> bit, is the read/write bit whose value will be placed in the SRW bit. This bit will be checked by the slave device to determine whether to go into transmit or receive mode. Before any transfer of data to or from the I<sup>2</sup>C bus, the microcontroller must initialise the bus; the following are steps to achieve this:

- Step 1  
Set the SIM2~SIM0 bits to "110" and SIMEN bit to "1" in the SIMC0 register to enable the I<sup>2</sup>C bus.
- Step 2  
Write the slave address of the device to the I<sup>2</sup>C bus address register SIMA.
- Step 3  
Set the SIME and SIM Multi-Function interrupt enable bit of the interrupt control register to enable the SIM interrupt and Multi-function interrupt.

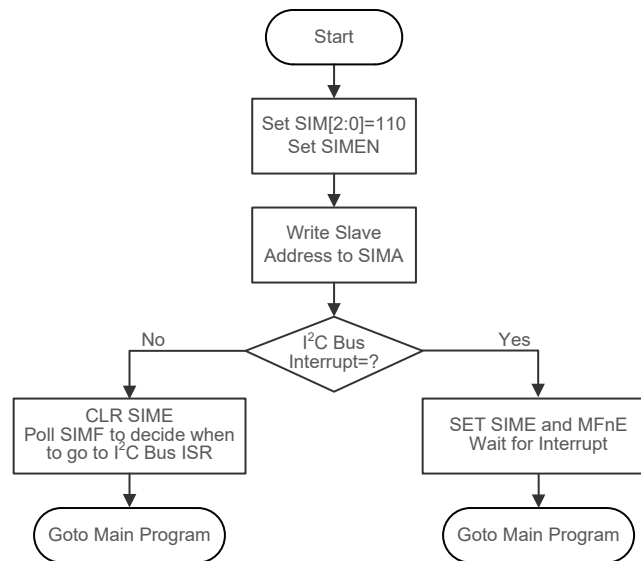

**I<sup>2</sup>C Bus Initialisation Flow Chart**

### **I<sup>2</sup>C Bus Start Signal**

The START signal can only be generated by the master device connected to the I<sup>2</sup>C bus and not by the slave device. This START signal will be detected by all devices connected to the I<sup>2</sup>C bus. When detected, this indicates that the I<sup>2</sup>C bus is busy and therefore the HBB bit will be set. A START condition occurs when a high to low transition on the SDA line takes place when the SCL line remains high.

### **I<sup>2</sup>C Slave Address**

The transmission of a START signal by the master will be detected by all devices on the I<sup>2</sup>C bus. To determine which slave device the master wishes to communicate with, the address of the slave device will be sent out immediately following the START signal. All slave devices, after receiving this 7-bit address data, will compare it with their own 7-bit slave address. If the address sent out by the master matches the internal address of the microcontroller slave device, then an internal I<sup>2</sup>C bus interrupt signal will be generated. The next bit following the address, which is the 8<sup>th</sup> bit, defines the read/write status and will be saved to the SRW bit of the SIMC1 register. The slave device will then transmit an acknowledge bit, which is a low level, as the 9<sup>th</sup> bit. The slave device will also set the status flag HAAS when the addresses match.

As an I<sup>2</sup>C bus interrupt can come from three sources, when the program enters the interrupt subroutine, the HAAS and SIMTOF bits should be examined to see whether the interrupt source has come from a matching slave address, the completion of a data byte transfer or the I<sup>2</sup>C bus time-out occurrence. When a slave address is matched, the devices must be placed in either the transmit mode and then write data to the SIMD register, or in the receive mode where it must implement a dummy read from the SIMD register to release the SCL line.

### **I<sup>2</sup>C Bus Read/Write Signal**

The SRW bit in the SIMC1 register defines whether the slave device wishes to read data from the I<sup>2</sup>C bus or write data to the I<sup>2</sup>C bus. The slave device should examine this bit to determine if it is to be a transmitter or a receiver. If the SRW flag is "1" then this indicates that the master device wishes to read data from the I<sup>2</sup>C bus, therefore the slave device must be setup to send data to the I<sup>2</sup>C bus as a transmitter. If the SRW flag is "0" then this indicates that the master wishes to send data to the I<sup>2</sup>C bus, therefore the slave device must be setup to read data from the I<sup>2</sup>C bus as a receiver.

### **I<sup>2</sup>C Bus Slave Address Acknowledge Signal**

After the master has transmitted a calling address, any slave device on the I<sup>2</sup>C bus, whose own internal address matches the calling address, must generate an acknowledge signal. The acknowledge signal will inform the master that a slave device has accepted its calling address. If no acknowledge signal is received by the master then a STOP signal must be transmitted by the master to end the communication. When the HAAS flag is high, the addresses have matched and the slave device must check the SRW flag to determine if it is to be a transmitter or a receiver. If the SRW flag is high, the slave device should be setup to be a transmitter so the HTX bit in the SIMC1 register should be set to "1". If the SRW flag is low, then the microcontroller slave device should be setup as a receiver and the HTX bit in the SIMC1 register should be set to "0".

### I<sup>2</sup>C Bus Data and Acknowledge Signal

The transmitted data is 8-bits wide and is transmitted after the slave device has acknowledged receipt of its slave address. The order of serial bit transmission is the MSB first and the LSB last. After receipt of 8-bits of data, the receiver must transmit an acknowledge signal, level "0", before it can receive the next data byte. If the slave transmitter does not receive an acknowledge bit signal from the master receiver, then the slave transmitter will release the SDA line to allow the master to send a STOP signal to release the I<sup>2</sup>C Bus. The corresponding data will be stored in the SIMD register. If setup as a transmitter, the slave device must first write the data to be transmitted into the SIMD register. If setup as a receiver, the slave device must read the transmitted data from the SIMD register.

When the slave receiver receives the data byte, it must generate an acknowledge bit, known as TXAK, on the 9<sup>th</sup> clock. The slave device, which is setup as a transmitter will check the RXAK bit in the SIMC1 register to determine if it is to send another data byte, if not then it will release the SDA line and await the receipt of a STOP signal from the master.

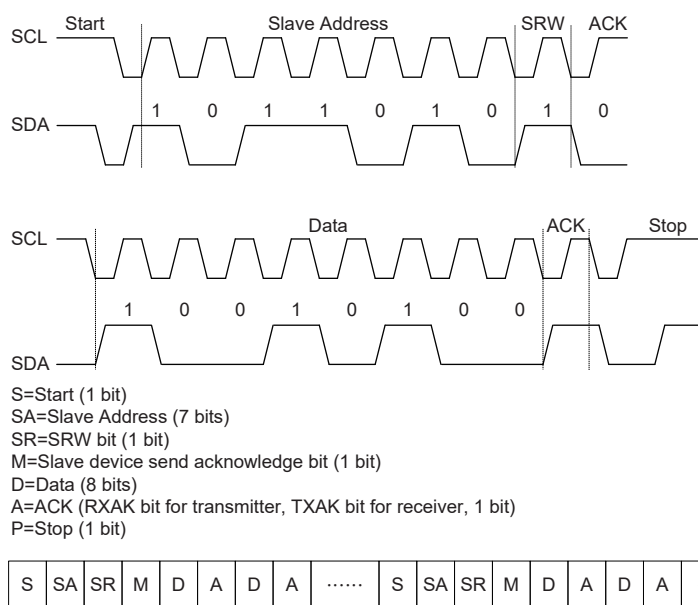

Note: \*When a slave address is matched, the device must be placed in either the transmit mode and then write data to the SIMD register, or in the receive mode where it must implement a dummy read from the SIMD register to release the SCL line.

**I<sup>2</sup>C Communication Timing Diagram**

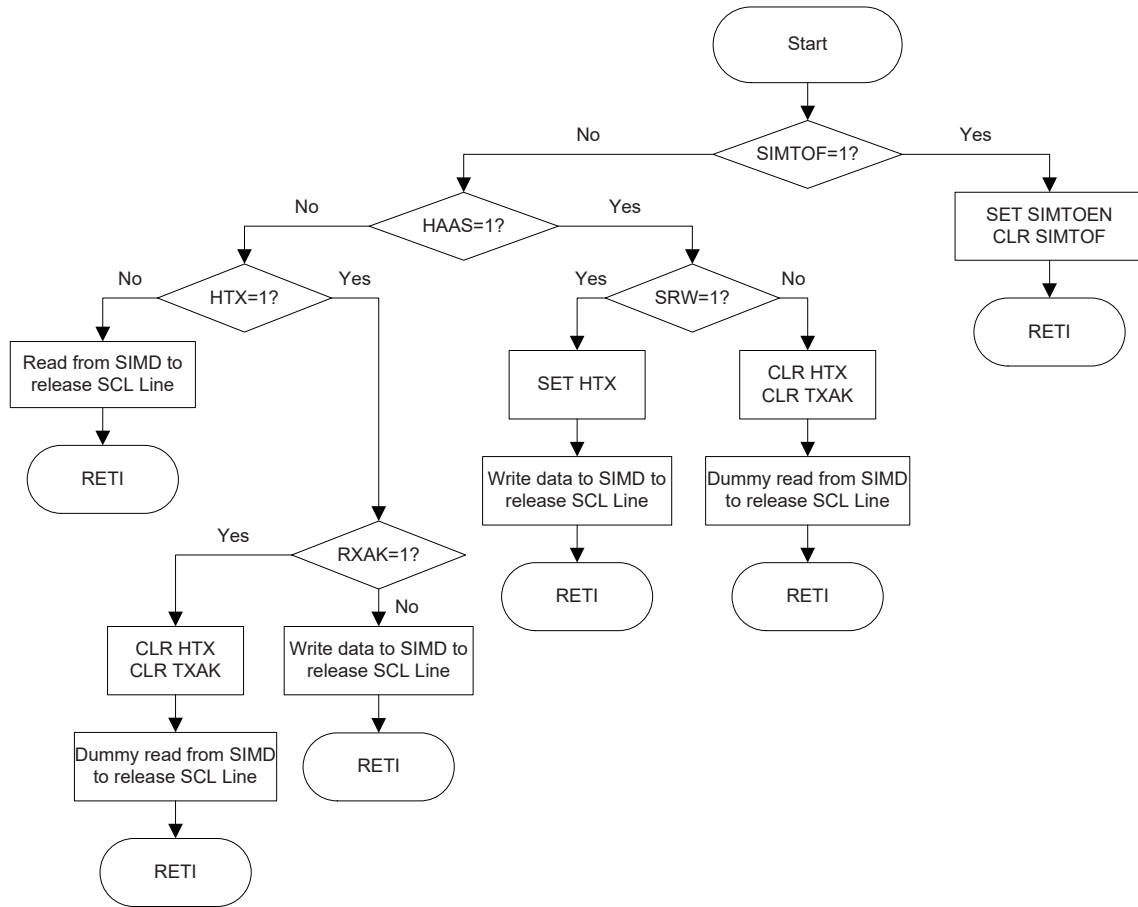

**I<sup>2</sup>C Bus ISR Flow Chart**

**I<sup>2</sup>C Time-out Control**

In order to reduce the I<sup>2</sup>C lockup problem due to reception of erroneous clock sources, a time-out function is provided. If the clock source connected to the I<sup>2</sup>C bus is not received for a while, then the I<sup>2</sup>C circuitry and registers will be reset after a certain time-out period. The time-out counter starts to count on an I<sup>2</sup>C bus "START" & "address match" condition, and is cleared by an SCL falling edge. Before the next SCL falling edge arrives, if the time elapsed is greater than the time-out period specified by the SIMTOC register, then a time-out condition will occur. The time-out function will stop when an I<sup>2</sup>C "STOP" condition occurs.

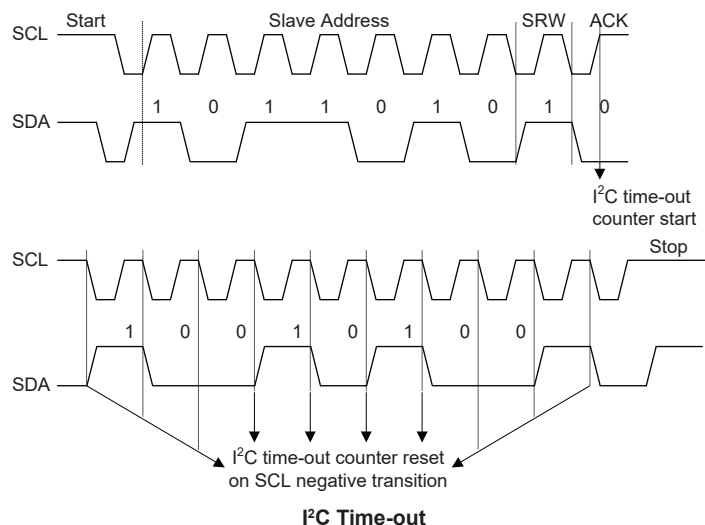

When an I<sup>2</sup>C time-out counter overflow occurs, the counter will stop and the SIMTOEN bit will be cleared to zero and the SIMTOF bit will be set high to indicate that a time-out condition has occurred. The time-out condition will also generate an interrupt which uses the I<sup>2</sup>C interrupt vector. When an I<sup>2</sup>C time-out occurs, the I<sup>2</sup>C internal circuitry will be reset and the registers will be reset into the following condition:

| Register          | After I <sup>2</sup> C Time-out |
|-------------------|---------------------------------|
| SIMD, SIMA, SIMC0 | No change                       |
| SIMC1             | Reset to POR condition          |

**I<sup>2</sup>C Register after Time-out**

The SIMTOF flag can be cleared by the application program. There are 64 time-out period selections which can be selected using the SIMTOS bits in the SIMTOC register. The time-out duration is calculated by the formula:  $((1-64) \times (32/f_{SUB}))$ . This gives a time-out period which ranges from about 1ms to 64ms.

• **SIMTOC Register**

| Bit  | 7       | 6      | 5       | 4       | 3       | 2       | 1       | 0       |
|------|---------|--------|---------|---------|---------|---------|---------|---------|
| Name | SIMTOEN | SIMTOF | SIMTOS5 | SIMTOS4 | SIMTOS3 | SIMTOS2 | SIMTOS1 | SIMTOS0 |
| R/W  | R/W     | R/W    | R/W     | R/W     | R/W     | R/W     | R/W     | R/W     |
| POR  | 0       | 0      | 0       | 0       | 0       | 0       | 0       | 0       |

Bit 7     **SIMTOEN**: SIM I<sup>2</sup>C Time-out control  
           0: Disable  
           1: Enable

Bit 6     **SIMTOF**: SIM I<sup>2</sup>C Time-out flag  
           0: No time-out occurred  
           1: Time-out occurred

Bit 5~0   **SIMTOS5~SIMTOS0**: SIM I<sup>2</sup>C Time-out period selection  
           I<sup>2</sup>C Time-out clock source is  $f_{SUB}/32$

I<sup>2</sup>C Time-out period is equal to  $(SIMTOS[5:0]+1) \times \frac{32}{f_{SUB}}$

## Serial Interface – SPIA

These devices contain an independent SPI function. It is important not to confuse this independent SPI function with the additional one contained within the combined SIM function, which is described in another section of this datasheet. This independent SPI function will carry the name SPIA to distinguish it from the other one in the SIM.

This SPIA interface is often used to communicate with external peripheral devices such as sensors, Flash or EEPROM memory devices, etc. Originally developed by Motorola, the four line SPI interface is a synchronous serial data interface that has a relatively simple communication protocol simplifying the programming requirements when communicating with external hardware devices.

The communication is full duplex and operates as a slave/master type, where the device can be either master or slave. Although the SPIA interface specification can control multiple slave devices from a single master, this device is provided only one  $\overline{SCSA}$  pin. If the master needs to control multiple slave devices from a single master, the master can use I/O pins to select the slave devices.

### SPIA Interface Operation

The SPIA interface is a full duplex synchronous serial data link. It is a four line interface with pin names SDIA, SDOA, SCKA and  $\overline{SCSA}$ . Pins SDIA and SDOA are the Serial Data Input and Serial Data Output lines, SCKA is the Serial Clock line and  $\overline{SCSA}$  is the Slave Select line. As the SPIA interface pins are pin-shared with other functions, the SPIA interface pins must first be selected by configuring the corresponding selection bits in the pin-shared function selection registers. The SPIA interface function is disabled or enabled using the SPIAEN bit in the SPIAC0 register. Communication between devices connected to the SPIA interface is carried out in a slave/master mode with all data transfer initiations being implemented by the master. The master also controls the clock/signal. As the device only contains a single  $\overline{SCSA}$  pin only one slave device can be utilised.

The  $\overline{SCSA}$  pin is controlled by the application program, set the SACSEN bit to "1" to enable the  $\overline{SCSA}$  pin function and clear the SACSEN bit to "0" to place the  $\overline{SCSA}$  pin into an I/O function.

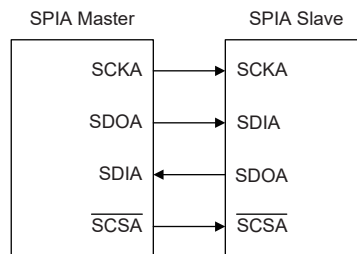

**SPIA Master/Slave Connection**

The SPIA Serial Interface function includes the following features:

- Full-duplex synchronous data transfer
- Both Master and Slave mode
- LSB first or MSB first data transmission modes
- Transmission complete flag
- Rising or falling active clock edge

The status of the SPIA interface pins is determined by a number of factors such as whether the device is in the master or slave mode and upon the condition of certain control bits such as SACSEN and SPIAEN.

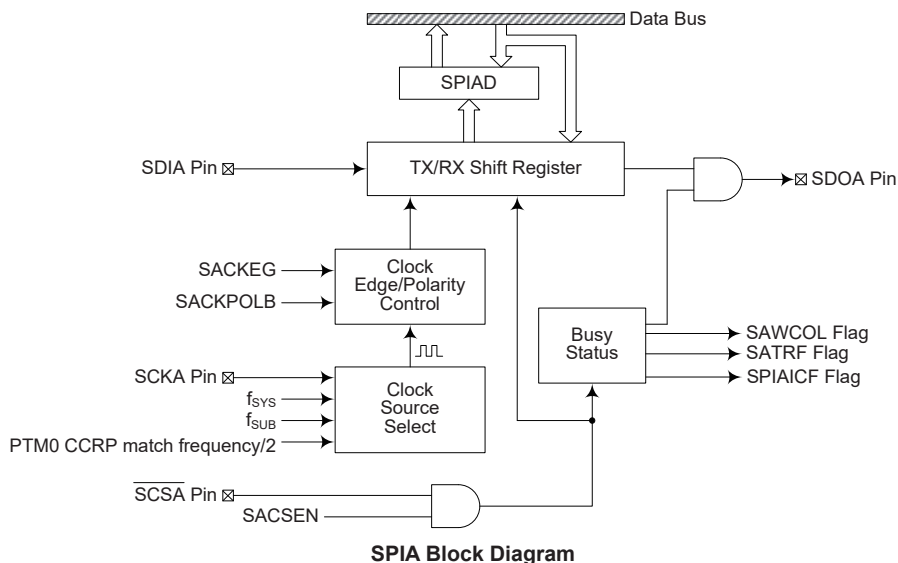

### SPIA Registers

There are three internal registers which control the overall operation of the SPIA interface. These are the SPIAD data register and two registers SPIAC0 and SPIAC1.

| Register Name | Bit    |        |          |        |       |        |        |         |
|---------------|--------|--------|----------|--------|-------|--------|--------|---------|
|               | 7      | 6      | 5        | 4      | 3     | 2      | 1      | 0       |
| SPIAC0        | SASPI2 | SASPI1 | SASPI0   | —      | —     | —      | SPIAEN | SPIAICF |
| SPIAC1        | —      | —      | SACKPOLB | SACKEG | SAMLS | SACSEN | SAWCOL | SATRF   |
| SPIAD         | D7     | D6     | D5       | D4     | D3    | D2     | D1     | D0      |

**SPIA Registers List**

#### • SPIAD Register

The SPIAD register is used to store the data being transmitted and received. Before the device writes data to the SPIA bus, the actual data to be transmitted must be placed in the SPIAD register. After the data is received from the SPIA bus, the device can read it from the SPIAD register. Any transmission or reception of data from the SPIA bus must be made via the SPIAD register.

| Bit  | 7   | 6   | 5   | 4   | 3   | 2   | 1   | 0   |
|------|-----|-----|-----|-----|-----|-----|-----|-----|
| Name | D7  | D6  | D5  | D4  | D3  | D2  | D1  | D0  |
| R/W  | R/W | R/W | R/W | R/W | R/W | R/W | R/W | R/W |
| POR  | x   | x   | x   | x   | x   | x   | x   | x   |

"x": unknown

There are also two control registers for the SPIA interface, SPIAC0 and SPIAC1. Register SPIAC0 is used to control the enable/disable function and to set the data transmission clock frequency. Register SPIAC1 is used for other control functions such as LSB/MSB selection, write collision flag, etc.

• **SPIAC0 Register**

| Bit  | 7      | 6      | 5      | 4 | 3 | 2 | 1      | 0       |
|------|--------|--------|--------|---|---|---|--------|---------|
| Name | SASPI2 | SASPI1 | SASPI0 | — | — | — | SPIAEN | SPIAICF |
| R/W  | R/W    | R/W    | R/W    | — | — | — | R/W    | R/W     |
| POR  | 1      | 1      | 1      | — | — | — | 0      | 0       |

Bit 7~5 **SASPI2~SASPI0**: SPIA Master/Slave clock select  
 000: SPIA master mode with clock  $f_{SYS} / 4$   
 001: SPIA master mode with clock  $f_{SYS} / 16$   
 010: SPIA master mode with clock  $f_{SYS} / 64$   
 011: SPIA master mode with clock  $f_{SUB}$   
 100: SPIA master mode with clock PTM0 CCRP match frequency/2  
 101: SPIA slave mode  
 11x: SPIA disable

Bit 4~2 Unimplemented, read as "0"

Bit 1 **SPIAEN**: SPIA Enable Control  
 0: Disable  
 1: Enable

The bit is the overall on/off control for the SPIA interface. When the SPIAEN bit is cleared to zero to disable the SPIA interface, the SDIA, SDOA, SCKA and SCSA lines will lose the SPI function and the SPIA operating current will be reduced to a minimum value. When the bit is high the SPIA interface is enabled.

Bit 0 **SPIAICF**: SPIA Incomplete Flag  
 0: SPIA incomplete condition not occurred  
 1: SPIA incomplete condition occurred

This bit is only available when the SPIA is configured to operate in an SPIA slave mode. If the SPIA operates in the slave mode with the SPIAEN and SACSSEN bits both being set to 1 but the SCSA line is pulled high by the external master device before the SPIA data transfer is completely finished, the SPIAICF bit will be set to 1 together with the SATRF bit. When this condition occurs, the corresponding interrupt will occur if the interrupt function is enabled. However, the SATRF bit will not be set to 1 if the SPIAICF bit is set to 1 by software application program.

• **SPIAC1 Register**

| Bit  | 7 | 6 | 5        | 4      | 3     | 2       | 1      | 0     |
|------|---|---|----------|--------|-------|---------|--------|-------|
| Name | — | — | SACKPOLB | SACKEG | SAMLS | SACSSEN | SAWCOL | SATRF |
| R/W  | — | — | R/W      | R/W    | R/W   | R/W     | R/W    | R/W   |
| POR  | — | — | 0        | 0      | 0     | 0       | 0      | 0     |

Bit 7~6 Unimplemented, read as "0"

Bit 5 **SACKPOLB**: SPIA clock line base condition selection  
 0: The SCKA line will be high when the clock is inactive.  
 1: The SCKA line will be low when the clock is inactive.

The SACKPOLB bit determines the base condition of the clock line, if the bit is high, then the SCKA line will be low when the clock is inactive. When the SACKPOLB bit is low, then the SCKA line will be high when the clock is inactive.

- Bit 4      **SACKEG**: SPIA SCKA clock active edge type selection  
SACKPOLB=0  
    0: SCKA is high base level and data capture at SCKA rising edge  
    1: SCKA is high base level and data capture at SCKA falling edge  
SACKPOLB=1  
    0: SCKA is low base level and data capture at SCKA falling edge  
    1: SCKA is low base level and data capture at SCKA rising edge  
The SACKEG and SACKPOLB bits are used to setup the way that the clock signal outputs and inputs data on the SPIA bus. These two bits must be configured before data transfer is executed otherwise an erroneous clock edge may be generated. The SACKPOLB bit determines the base condition of the clock line, if the bit is high, then the SCKA line will be low when the clock is inactive. When the SACKPOLB bit is low, then the SCKA line will be high when the clock is inactive. The SACKEG bit determines active clock edge type which depends upon the condition of SACKPOLB bit.
- Bit 3      **SAMLS**: SPIA data shift order  
    0: LSB first  
    1: MSB first  
This is the data shift select bit and is used to select how the data is transferred, either MSB or LSB first. Setting the bit high will select MSB first and low for LSB first.
- Bit 2      **SACSEN**: SPIA  $\overline{SCSA}$  pin control  
    0: Disable  
    1: Enable  
The SACSEN bit is used as an enable/disable for the  $\overline{SCSA}$  pin. If this bit is low, then the  $\overline{SCSA}$  pin function will be disabled and can be placed into I/O pin or other pin-shared functions. If the bit is high, the  $\overline{SCSA}$  pin will be enabled and used as a select pin.
- Bit 1      **SAWCOL**: SPIA write collision flag  
    0: No collision  
    1: Collision  
The SAWCOL flag is used to detect whether a data collision has occurred or not. If this bit is high, it means that data has been attempted to be written to the SPIAD register during a data transfer operation. This writing operation will be ignored if data is being transferred. This bit can be cleared by the application program.
- Bit 0      **SATRF**: SPIA Transmit/Receive complete flag  
    0: SPIA data is being transferred  
    1: SPIA data transfer is completed  
The SATRF bit is the Transmit/Receive Complete flag and is set to 1 automatically when an SPIA data transfer is completed, but must cleared to 0 by the application program. It can be used to generate an interrupt.

### SPIA Communication

After the SPIA interface is enabled by setting the SPIAEN bit high, then in the Master Mode, when data is written to the SPIAD register, transmission/reception will begin simultaneously. When the data transfer is complete, the SATRF flag will be set automatically, but must be cleared using the application program. In the Slave Mode, when the clock signal from the master has been received, any data in the SPIA register will be transmitted and any data on the SDIA pin will be shifted into the SPIAD registers.

The master should output a  $\overline{SCSA}$  signal to enable the slave device before a clock signal is provided. The slave data to be transferred should be well prepared at the appropriate moment relative to the  $\overline{SCSA}$  signal depending upon the configurations of the SACKPOLB bit and SACKEG bit. The accompanying timing diagram shows the relationship between the slave data and  $\overline{SCSA}$  signal for various configurations of the SACKPOLB and SACKEG bits. The SPIA will continue to function if the SPIA clock source is active.

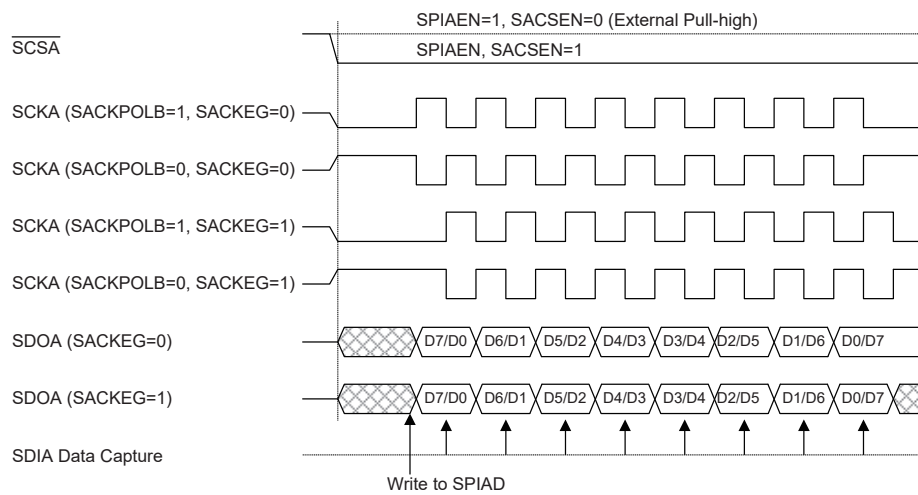

**SPIA Master Mode Timing**

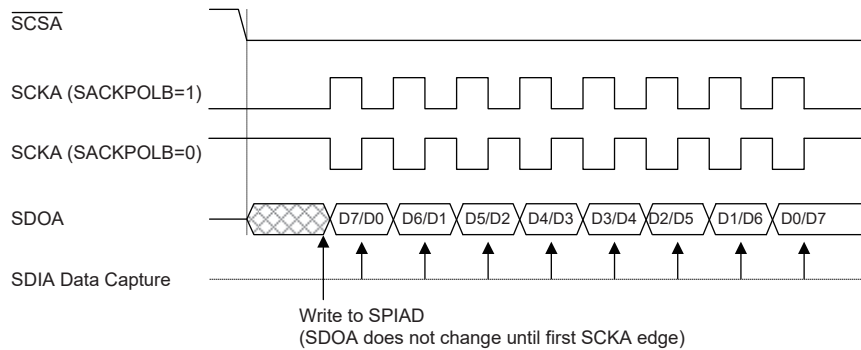

**SPIA Master Mode Timing – SACKEG=0**

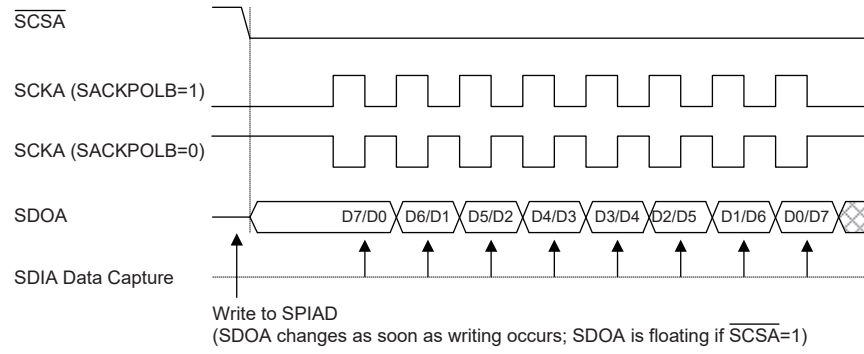

Note: For SPIA slave mode, if SPIAEN=1 and SACSEN=0, SPIA is always enabled and ignores the  $\overline{SCSA}$  level.

**SPIA Master Mode Timing – SACKEG=1**

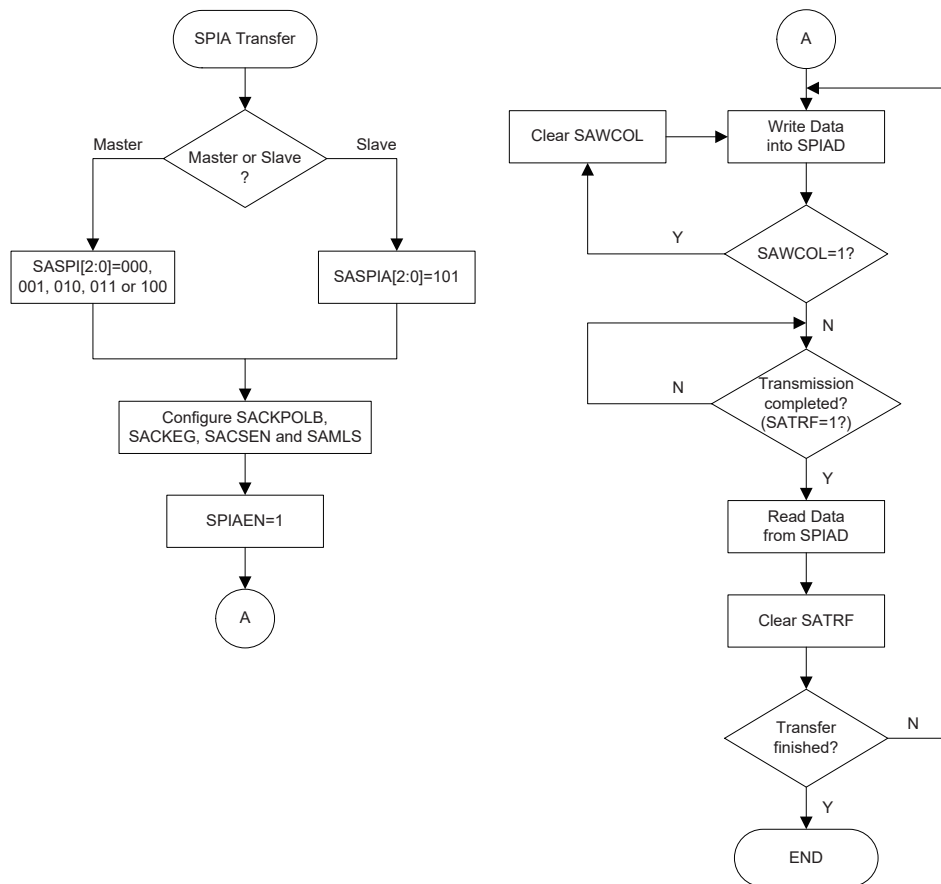

**SPIA Transfer Control Flow Chart**

## SPIA Bus Enable/Disable

To enable the SPIA bus, set  $SACSEN=1$  and  $\overline{SCSA}=0$ , then wait for data to be written into the SPIAD (TXRX buffer) register. For the Master Mode, after data has been written to the SPIAD (TXRX buffer) register, then transmission or reception will start automatically. When all the data has been transferred the SATRF bit should be set. For the Slave Mode, when clock pulses are received on SCKA, data in the TXRX buffer will be shifted out or data on SDIA will be shifted in.

When the SPIA bus is disabled, the SCKA, SDIA, SDOA and  $\overline{SCSA}$  pins can become I/O pins or other pin-shared functions using the corresponding pin-shared function selection bits.

## SPIA Operation

All communication is carried out using the 4-line interface for either Master or Slave Mode.

The SACSEN bit in the SPIAC1 register controls the overall function of the SPIA interface. Setting this bit high will enable the SPIA interface by allowing the  $\overline{SCSA}$  line to be active, which can then be used to control the SPIA interface. If the SACSEN bit is low, the SPIA interface will be disabled and the  $\overline{SCSA}$  line will be an I/O pin or other pin-shared functions and can therefore not be used for control of the SPIA interface. If the SACSEN bit and the SPIAEN bit in the SPIAC0 register are set high, this will place the SDIA line in a floating condition and the SDOA line high. If in Master Mode the SCKA line will be either high or low depending upon the clock polarity selection bit SACKPOLB in the SPIAC1 register. If in Slave Mode the SCKA line will be in a floating condition. If SPIAEN is low, then the bus will be disabled and  $\overline{SCSA}$ , SDIA, SDOA and SCKA pins will all become I/O pins or other pin-shared functions using the corresponding pin-shared function selection bits. In the Master Mode the Master will always generate the clock signal. The clock and data transmission will be initiated after data has been written into the SPIAD register. In the Slave Mode, the clock signal will be received from an external master device for both data transmission and reception. The following sequences show the order to be followed for data transfer in both Master and Slave Mode.

### Master Mode

- Step 1  
Select the clock source and Master mode using the SASPI2~SASPI0 bits in the SPIAC0 control register.
- Step 2  
Setup the SACSEN bit and setup the SAMLS bit to choose if the data is MSB or LSB shifted first, this must be same as the Slave device.
- Step 3  
Setup the SPIAEN bit in the SPIAC0 control register to enable the SPIA interface.
- Step 4  
For write operations: write the data to the SPIAD register, which will actually place the data into the TXRX buffer. Then use the SCKA and  $\overline{SCSA}$  lines to output the data. After this go to step 5.  
For read operations: the data transferred in on the SDIA line will be stored in the TXRX buffer until all the data has been received at which point it will be latched into the SPIAD register.
- Step 5  
Check the SAWCOL bit if set high then a collision error has occurred so return to step 4. If equal to zero then go to the following step.
- Step 6  
Check the SATRF bit or wait for a SPIA serial bus interrupt.

- Step 7  
Read data from the SPIAD register.
- Step 8  
Clear SATRF.
- Step 9  
Go to step 4.

#### **Slave Mode**

- Step 1  
Select the SPI Slave mode using the SASPI2~SASPI0 bits in the SPIAC0 control register
- Step 2  
Setup the SACSEN bit and setup the SAMLS bit to choose if the data is MSB or LSB shifted first, this setting must be the same with the Master device.
- Step 3  
Setup the SPIAEN bit in the SPIAC0 control register to enable the SPIA interface.
- Step 4  
For write operations: write the data to the SPIAD register, which will actually place the data into the TXRX buffer. Then wait for the master clock SCKA and  $\overline{SCSA}$  signal. After this, go to step 5.  
For read operations: the data transferred in on the SDIA line will be stored in the TXRX buffer until all the data has been received at which point it will be latched into the SPIAD register.
- Step 5  
Check the SAWCOL bit if set high then a collision error has occurred so return to step 4. If equal to zero then go to the following step.
- Step 6  
Check the SATRF bit or wait for a SPIA serial bus interrupt.
- Step 7  
Read data from the SPIAD register.
- Step 8  
Clear SATRF.
- Step 9  
Go to step 4.

#### **Error Detection**

The SAWCOL bit in the SPIAC1 register is provided to indicate errors during data transfer. The bit is set by the SPIA serial Interface but must be cleared by the application program. This bit indicates a data collision has occurred which happens if a write to the SPIAD register takes place during a data transfer operation and will prevent the write operation from continuing.

## UART Interface

These devices contain up to three integrated full-duplex asynchronous serial communications UART interfaces that enable communication with external devices that contain a serial interface. The UART function has many features and can transmit and receive data serially by transferring a frame of data with eight or nine data bits per transmission as well as being able to detect errors when the data is overwritten or incorrectly framed. The UART function possesses its own internal interrupt which can be used to indicate when a reception occurs or when a transmission terminates.

| Decive              | UART Interface |
|---------------------|----------------|
| HT66F2350/HT66F2360 | 2              |
| HT66F2370/HT66F2390 | 3              |

Each integrated UART function contains the following features:

- Full-duplex, asynchronous communication
- 8 or 9 bits character length
- Even, odd or no parity options
- One or two stop bits
- Baud rate generator with 8-bit prescaler
- Parity, framing, noise and overrun error detection
- Support for interrupt on address detect (last character bit=1)
- Separately enabled transmitter and receiver
- 2-byte Deep FIFO Receive Data Buffer
- RX pin wake-up function
- Transmit and receive interrupts
- Interrupts can be initialized by the following conditions:
  - ♦ Transmitter Empty
  - ♦ Transmitter Idle
  - ♦ Receiver Full
  - ♦ Receiver Overrun
  - ♦ Address Mode Detect

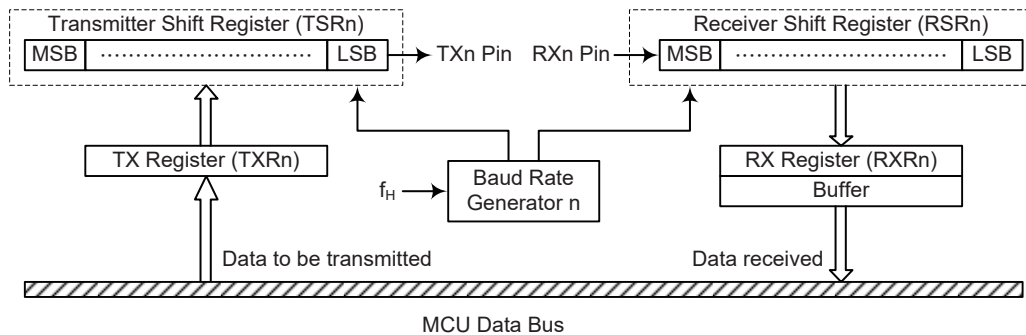

**UART Data Transfer Block Diagram**

## UART External Pin

To communicate with an external serial interface, the internal UARTn has two external pins known as TXn and RXn. The TXn and RXn pins are the UARTn transmitter and receiver pins respectively. The TXn and RXn pin function should first be selected by the corresponding pin-shared function selection register before the UARTn function is used. Along with the UARTENn bit, the TXENn and RXENn bits, if set, will automatically setup the TXn and RXn pins to their respective TXn output and RXn input conditions and disable any pull-high resistor option which may exist on the TXn and RXn pins. When the TXn or RXn pin function is disabled by clearing the UARTENn, TXENn or RXENn bit, the TXn or RXn pin will be set to a floating state. At this time whether the internal pull-high resistor is connected to the TXn or RXn pin or not is determined by the corresponding I/O pull-high function control bit.

## UART Data Transfer Scheme

The above diagram shows the overall data transfer structure arrangement for the UARTn interface. The actual data to be transmitted from the MCU is first transferred to the TXRn register by the application program. The data will then be transferred to the Transmit Shift Register from where it will be shifted out, LSB first, onto the TXn pin at a rate controlled by the Baud Rate Generator n. Only the TXRn register is mapped onto the MCU Data Memory, the Transmit Shift Register is not mapped and is therefore inaccessible to the application program.

Data to be received by the UARTn is accepted on the external RXn pin, from where it is shifted in, LSB first, to the Receiver Shift Register at a rate controlled by the Baud Rate Generator. When the shift register is full, the data will then be transferred from the shift register to the internal RXRn register, where it is buffered and can be manipulated by the application program. Only the TXRn register is mapped onto the MCU Data Memory, the Receiver Shift Register is not mapped and is therefore inaccessible to the application program.

It should be noted that the actual register for data transmission and reception, although referred to in the text, and in application programs, as separate TXRn and RXRn registers, only exists as a single shared register in the Data Memory. This shared register known as the TXR\_RXRn register is used for both data transmission and data reception.

## UART Status and Control Registers

There are five control registers associated with the UARTn function. The UnSR, UnCR1 and UnCR2 registers control the overall function of the UARTn, while the BRGn register controls the Baud rate. The actual data to be transmitted and received on the serial interface is managed through the TXR\_RXRn data registers.

- **TXR\_RXRn Register**

The TXR\_RXRn register is the data register which is used to store the data to be transmitted on the TXn pin or being received from the RXn pin.

| Bit  | 7   | 6   | 5   | 4   | 3   | 2   | 1   | 0   |
|------|-----|-----|-----|-----|-----|-----|-----|-----|
| Name | D7  | D6  | D5  | D4  | D3  | D2  | D1  | D0  |
| R/W  | R/W | R/W | R/W | R/W | R/W | R/W | R/W | R/W |
| POR  | x   | x   | x   | x   | x   | x   | x   | x   |

"x": unknown

Bit 7~0      **D7~D0**: UARTn Transmit/Receive Data bits

• **UnSR Register**

The UnSR register is the status register for the UARTn, which can be read by the program to determine the present status of the UARTn. All flags within the UnSR register are read only and further explanations are given below.

| Bit  | 7     | 6   | 5     | 4     | 3      | 2     | 1      | 0     |
|------|-------|-----|-------|-------|--------|-------|--------|-------|
| Name | PERRn | NFn | FERRn | OERRn | RIDLEn | RXIFn | TIDLEn | TXIFn |
| R/W  | R     | R   | R     | R     | R      | R     | R      | R     |
| POR  | 0     | 0   | 0     | 0     | 1      | 0     | 1      | 1     |

- Bit 7**      **PERRn:** Parity error flag  
0: No parity error is detected  
1: Parity error is detected
- The PERRn flag is the parity error flag. When this read only flag is "0", it indicates a parity error has not been detected. When the flag is "1", it indicates that the parity of the received word is incorrect. This error flag is applicable only if Parity mode (odd or even) is selected. The flag can also be cleared by a software sequence which involves a read to the status register UnSR followed by an access to the TXR\_RXRn data register.
- Bit 6**      **NFn:** Noise flag  
0: No noise is detected  
1: Noise is detected
- The NFn flag is the noise flag. When this read only flag is "0", it indicates no noise condition. When the flag is "1", it indicates that the UARTn has detected noise on the receiver input. The NFn flag is set during the same cycle as the RXIFn flag but will not be set in the case of an overrun. The NFn flag can be cleared by a software sequence which will involve a read to the status register UnSR followed by an access to the TXR\_RXRn data register.
- Bit 5**      **FERRn:** Framing error flag  
0: No framing error is detected  
1: Framing error is detected
- The FERRn flag is the framing error flag. When this read only flag is "0", it indicates that there is no framing error. When the flag is "1", it indicates that a framing error has been detected for the current character. The flag can also be cleared by a software sequence which will involve a read to the status register UnSR followed by an access to the TXR\_RXRn data register.
- Bit 4**      **OERRn:** Overrun error flag  
0: No overrun error is detected  
1: Overrun error is detected
- The OERRn flag is the overrun error flag which indicates when the receiver buffer has overflowed. When this read only flag is "0", it indicates that there is no overrun error. When the flag is "1", it indicates that an overrun error occurs which will inhibit further transfers to the TXR\_RXRn receive data register. The flag is cleared by a software sequence, which is a read to the status register UnSR followed by an access to the TXR\_RXRn data register.

- Bit 3      **RIDLEn**: Receiver status  
0: data reception is in progress (data being received)  
1: no data reception is in progress (receiver is idle)  
The RIDLEn flag is the receiver status flag. When this read only flag is "0", it indicates that the receiver is between the initial detection of the start bit and the completion of the stop bit. When the flag is "1", it indicates that the receiver is idle. Between the completion of the stop bit and the detection of the next start bit, the RIDLEn bit is "1" indicating that the UARTn receiver is idle and the RXn pin stays in logic high condition.
- Bit 2      **RXIFn**: Receive TXR\_RXRn data register status  
0: TXR\_RXRn data register is empty  
1: TXR\_RXRn data register has available data  
The RXIFn flag is the receive data register status flag. When this read only flag is "0", it indicates that the TXR\_RXRn read data register is empty. When the flag is "1", it indicates that the TXR\_RXRn read data register contains new data. When the contents of the shift register are transferred to the TXR\_RXRn register, an interrupt is generated if RIEn=1 in the UnCR2 register. If one or more errors are detected in the received word, the appropriate receive-related flags NF<sub>n</sub>, FERR<sub>n</sub>, and/or PERR<sub>n</sub> are set within the same clock cycle. The RXIFn flag will eventually be cleared when the UnSR register is read with RXIFn set, followed by a read from the TXR\_RXRn register, and if the TXR\_RXRn register has no more new data available.
- Bit 1      **TIDLEn**: Transmission status  
0: data transmission is in progress (data being transmitted)  
1: no data transmission is in progress (transmitter is idle)  
The TIDLEn flag is known as the transmission complete flag. When this read only flag is "0", it indicates that a transmission is in progress. This flag will be set to "1" when the TXIFn flag is "1" and when there is no transmit data or break character being transmitted. When TIDLEn is equal to 1, the TXn pin becomes idle with the pin state in logic high condition. The TIDLEn flag is cleared by reading the UnSR register with TIDLEn set and then writing to the TXR\_RXRn register. The flag is not generated when a data character or a break is queued and ready to be sent.
- Bit 0      **TXIFn**: Transmit TXR data register status  
0: character is not transferred to the transmit shift register  
1: character has transferred to the transmit shift register (TXR\_RXRn data register is empty)  
The TXIFn flag is the transmit data register empty flag. When this read only flag is "0", it indicates that the character is not transferred to the transmitter shift register. When the flag is "1", it indicates that the transmitter shift register has received a character from the TXR\_RXRn data register. The TXIFn flag is cleared by reading the UARTn status register (UnSR) with TXIFn set and then writing to the TXR\_RXRn data register. Note that when the TXENn bit is set, the TXIFn flag bit will also be set since the transmit data register is not yet full.

• **UnCR1 Register**

The UnCR1 register together with the UnCR2 register are the UARTn control registers that are used to set the various options for the UARTn function such as overall on/off control, parity control, data transfer bit length, etc. Further explanation on each of the bits is given below.

| Bit  | 7       | 6    | 5     | 4    | 3      | 2      | 1    | 0    |
|------|---------|------|-------|------|--------|--------|------|------|
| Name | UARTENn | BNOn | PRENn | PRTn | STOPSn | TXBRKn | RX8n | TX8n |
| R/W  | R/W     | R/W  | R/W   | R/W  | R/W    | R/W    | R    | W    |
| POR  | 0       | 0    | 0     | 0    | 0      | 0      | x    | 0    |

"x": unknown

- Bit 7**     **UARTENn:** UARTn function enable control  
0: Disable UARTn; TXn and RXn pins are in a high impedance state.  
1: Enable UARTn; TXn and RXn pins function as UARTn pins  
The UARTENn bit is the UARTn enable bit. When this bit is equal to "0", the UARTn will be disabled and the RXn pin as well as the TXn pin will be set in a high impedance state. When the bit is equal to "1", the UARTn will be enabled and the TXn and RXn pins will function as defined by the TXENn and RXENn enable control bits. When the UARTn is disabled, it will empty the buffer so any character remaining in the buffer will be discarded. In addition, the value of the baud rate counter will be reset. If the UARTn is disabled, all error and status flags will be reset. Also the TXENn, RXENn, TXBRKn, RXIFn, OERRn, FERRn, PERRn and NFn bits will be cleared, while the TIDLEn, TXIFn and RIDLEn bits will be set. Other control bits in UnCR1, UnCR2 and BRGn registers will remain unaffected. If the UARTn is active and the UARTENn bit is cleared, all pending transmissions and receptions will be terminated and the module will be reset as defined above. When the UARTn is re-enabled, it will restart in the same configuration.
- Bit 6**     **BNOn:** Number of data transfer bits selection  
0: 8-bit data transfer  
1: 9-bit data transfer  
This bit is used to select the data length format, which can have a choice of either 8-bit or 9-bit format. When this bit is equal to "1", a 9-bit data length format will be selected. If the bit is equal to "0", then an 8-bit data length format will be selected. If 9-bit data length format is selected, then bits RX8n and TX8n will be used to store the 9th bit of the received and transmitted data respectively.
- Bit 5**     **PRENn:** Parity function enable control  
0: Parity function is disabled  
1: Parity function is enabled  
This bit is the parity function enable bit. When this bit is equal to 1, the parity function will be enabled. If the bit is equal to 0, then the parity function will be disabled.
- Bit 4**     **PRTn:** Parity type selection bit  
0: Even parity for parity generator  
1: Odd parity for parity generator  
This bit is the parity type selection bit. When this bit is equal to 1, odd parity type will be selected. If the bit is equal to 0, then even parity type will be selected.
- Bit 3**     **STOPSn:** Number of stop bits selection  
0: One stop bit format is used  
1: Two stop bits format is used  
This bit determines if one or two stop bits are to be used. When this bit is equal to "1", two stop bits format are used. If the bit is equal to "0", then only one stop bit format is used.

- Bit 2     **TXBRKn**: Transmit break character  
           0: No break character is transmitted  
           1: Break characters transmit
- The TXBRKn bit is the Transmit Break Character bit. When this bit is equal to "0", there are no break characters and the TXn pin operates normally. When the bit is equal to "1", there are transmit break characters and the transmitter will send logic zeros. When this bit is equal to "1", after the buffered data has been transmitted, the transmitter output is held low for a minimum of a 13-bit length and until the TXBRKn bit is reset.
- Bit 1     **RX8n**: Receive data bit 8 for 9-bit data transfer format (read only)
- This bit is only used if 9-bit data transfers are used, in which case this bit location will store the 9<sup>th</sup> bit of the received data known as RX8n. The BNO<sub>n</sub> bit is used to determine whether data transfers are in 8-bit or 9-bit format.
- Bit 0     **TX8n**: Transmit data bit 8 for 9-bit data transfer format (write only)
- This bit is only used if 9-bit data transfers are used, in which case this bit location will store the 9<sup>th</sup> bit of the transmitted data known as TX8n. The BNO<sub>n</sub> bit is used to determine whether data transfers are in 8-bit or 9-bit format.

• **UnCR2 Register**

The UnCR2 register is the second of the UART<sub>n</sub> control registers and serves several purposes. One of its main functions is to control the basic enable/disable operation if the UART<sub>n</sub> Transmitter and Receiver as well as enabling the various UART<sub>n</sub> interrupt sources. The register also serves to control the baud rate speed, receiver wake-up function enable and the address detect function enable. Further explanation on each of the bits is given below.

| Bit  | 7                 | 6                 | 5                 | 4                  | 3                  | 2                 | 1                 | 0                 |
|------|-------------------|-------------------|-------------------|--------------------|--------------------|-------------------|-------------------|-------------------|
| Name | TXEN <sub>n</sub> | RXEN <sub>n</sub> | BRGH <sub>n</sub> | ADDEN <sub>n</sub> | WAKEN <sub>n</sub> | RIEN <sub>n</sub> | TIIE <sub>n</sub> | TEIE <sub>n</sub> |
| R/W  | R/W               | R/W               | R/W               | R/W                | R/W                | R/W               | R/W               | R/W               |
| POR  | 0                 | 0                 | 0                 | 0                  | 0                  | 0                 | 0                 | 0                 |

- Bit 7     **TXEN<sub>n</sub>**: UART<sub>n</sub> Transmitter enable control  
           0: UART<sub>n</sub> Transmitter is disabled  
           1: UART<sub>n</sub> Transmitter is enabled
- The TXEN<sub>n</sub> bit is the Transmitter Enable Bit. When this bit is equal to "0", the transmitter will be disabled with any pending data transmissions being aborted. In addition the buffers will be reset. If the TXEN<sub>n</sub> bit is equal to "1" and the UARTEN<sub>n</sub> bit is also equal to 1, the transmitter will be enabled and the TXn pin will be controlled by the UART<sub>n</sub>. Clearing the TXEN<sub>n</sub> bit during a transmission will cause the data transmission to be aborted and will reset the transmitter.
- Bit 6     **RXEN<sub>n</sub>**: UART<sub>n</sub> Receiver enable control  
           0: UART<sub>n</sub> Receiver is disabled  
           1: UART<sub>n</sub> Receiver is enabled
- The RXEN<sub>n</sub> bit is the Receiver Enable Bit. When this bit is equal to "0", the receiver will be disabled with any pending data receptions being aborted. In addition the receiver buffers will be reset. If the RXEN<sub>n</sub> bit is equal to "1" and the UARTEN<sub>n</sub> bit is also equal to 1, the receiver will be enabled and the RXn pin will be controlled by the UART<sub>n</sub>. Clearing the RXEN<sub>n</sub> bit during a reception will cause the data reception to be aborted and will reset the receiver.
- Bit 5     **BRGH<sub>n</sub>**: Baud Rate speed selection  
           0: Low speed baud rate  
           1: High speed baud rate
- The bit named BRGH<sub>n</sub> selects the high or low speed mode of the Baud Rate Generator n. This bit, together with the value placed in the baud rate register, BRG<sub>n</sub>, controls the baud rate of the UART<sub>n</sub>. If the bit is equal to 0, the low speed mode is selected.

- Bit 4      **ADDENn**: Address detect function enable control  
             0: Address detection function is disabled  
             1: Address detection function is enabled  
 The bit named ADDENn is the address detection function enable control bit. When this bit is equal to 1, the address detection function is enabled. When it occurs, if the 8<sup>th</sup> bit, which corresponds to RX7n if BNO=0, or the 9<sup>th</sup> bit, which corresponds to RX8n if BNO=1, has a value of "1", then the received word will be identified as an address, rather than data. If the corresponding interrupt is enabled, an interrupt request will be generated each time the received word has the address bit set, which is the 8<sup>th</sup> or 9<sup>th</sup> bit depending on the value of the BNO<sub>n</sub> bit. If the address bit known as the 8<sup>th</sup> or 9<sup>th</sup> bit of the received word is "0" with the address detection function being enabled, an interrupt will not be generated and the received data will be discarded.
- Bit 3      **WAKEn**: RXn pin falling edge wake-up function enable control  
             0: RXn pin wake-up UARTn function is disabled  
             1: RXn pin wake-up UARTn function is enabled  
 The bit is used to control the wake-up UARTn function when a falling edge on the RXn pin occurs. Note that this bit is only available when the UARTn clock, f<sub>ih</sub>, is switched off. There will be no RXn pin wake-up UARTn function if the UARTn clock, f<sub>ih</sub>, exists. If the WAKEn bit is equal to 1 and the UARTn clock, f<sub>ih</sub>, is switched off, a UARTn wake-up request will be initiated when a falling edge on the RXn pin occurs. When this request happens and the corresponding interrupt is enabled, an RXn pin wake-up UARTn interrupt will be generated to inform the MCU to wake up the UARTn function by switching on the UARTn clock, f<sub>ih</sub>, via the application programs. Otherwise, the UARTn function can not resume even if there is a falling edge on the RXn pin when the WAKEn bit is cleared to 0.
- Bit 2      **RIEn**: Receiver interrupt enable control  
             0: Receiver related interrupt is disabled  
             1: Receiver related interrupt is enabled  
 The bit enables or disables the receiver interrupt. If this bit is equal to 1 and when the receiver overrun flag OERRn or received data available flag RXIFn is set, the UARTn interrupt request flag will be set. If this bit is equal to 0, the UARTn interrupt request flag will not be influenced by the condition of the OERRn or RXIFn flags.
- Bit 1      **TIEn**: Transmitter Idle interrupt enable control  
             0: Transmitter idle interrupt is disabled  
             1: Transmitter idle interrupt is enabled  
 The bit enables or disables the transmitter idle interrupt. If this bit is equal to 1 and when the transmitter idle flag TIDLEn is set, due to a transmitter idle condition, the UARTn interrupt request flag will be set. If this bit is equal to 0, the UARTn interrupt request flag will not be influenced by the condition of the TIDLEn flag.
- Bit 0      **TEIEn**: Transmitter Empty interrupt enable control  
             0: Transmitter empty interrupt is disabled  
             1: Transmitter empty interrupt is enabled  
 The bit enables or disables the transmitter empty interrupt. If this bit is equal to 1 and when the transmitter empty flag TXIFn is set, due to a transmitter empty condition, the UARTn interrupt request flag will be set. If this bit is equal to 0, the UARTn interrupt request flag will not be influenced by the condition of the TXIFn flag.

## Baud Rate Generator

To setup the speed of the serial data communication, the UARTn function contains its own dedicated baud rate generator. The baud rate is controlled by its own internal free running 8-bit timer, the period of which is determined by two factors. The first of these is the value placed in the BRGn register and the second is the value of the BRGHn bit within the UnCR2 control register. The BRGHn bit decides, if the baud rate generator is to be used in a high speed mode or low speed mode, which in turn determines the formula that is used to calculate the baud rate. The value in the BRGn register, N, which is used in the following baud rate calculation formula determines the division factor. Note that N is the decimal value placed in the BRGn register and has a range of between 0 and 255.

| UnCR2 BRGHn Bit | 0                  | 1                  |
|-----------------|--------------------|--------------------|
| Baud Rate (BR)  | $f_H / [64 (N+1)]$ | $f_H / [16 (N+1)]$ |

By programming the BRGHn bit which allows selection of the related formula and programming the required value in the BRGn register, the required baud rate can be setup. Note that because the actual baud rate is determined using a discrete value, N, placed in the BRGn register, there will be an error associated between the actual and requested value. The following example shows how the BRGn register value N and the error value can be calculated.

### • BRGn Register

| Bit  | 7   | 6   | 5   | 4   | 3   | 2   | 1   | 0   |
|------|-----|-----|-----|-----|-----|-----|-----|-----|
| Name | D7  | D6  | D5  | D4  | D3  | D2  | D1  | D0  |
| R/W  | R/W | R/W | R/W | R/W | R/W | R/W | R/W | R/W |
| POR  | x   | x   | x   | x   | x   | x   | x   | x   |

"x": unknown

Bit 7~0 **D7~D0**: Baud Rate values

By programming the BRGHn bit in the UnCR2 register which allows selection of the related formula described above and programming the required value in the BRGn register, the required baud rate can be setup.

### Calculating the Baud Rate and Error Values

For a clock frequency of 4MHz, and with BRGHn set to 0 determine the BRGn register value N, the actual baud rate and the error value for a desired baud rate of 4800.

From the above table the desired baud rate  $BR = f_H / [64 (N+1)]$

Re-arranging this equation gives  $N = [f_H / (BR \times 64)] - 1$

Giving a value for  $N = [4000000 / (4800 \times 64)] - 1 = 12.0208$

To obtain the closest value, a decimal value of 12 should be placed into the BRGn register. This gives an actual or calculated baud rate value of  $BR = 4000000 / [64 \times (12+1)] = 4808$

Therefore the error is equal to  $(4808 - 4800) / 4800 = 0.16\%$

## UART Setup and Control

For data transfer, the UARTn function utilizes a non-return-to-zero, more commonly known as NRZ, format. This is composed of one start bit, eight or nine data bits and one or two stop bits. Parity is supported by the UARTn hardware and can be setup to be even, odd or no parity. For the most common data format, 8 data bits along with no parity and one stop bit, denoted as 8, N, 1, is used as the default setting, which is the setting at power-on. The number of data bits and stop bits, along with the parity, are setup by programming the corresponding BNO<sub>n</sub>, PRT<sub>n</sub>, PREN<sub>n</sub> and STOPS<sub>n</sub> bits in the UnCR1 register. The baud rate used to transmit and receive data is setup using the internal 8-bit baud rate generator, while the data is transmitted and received LSB first. Although the transmitter and receiver of the UARTn are functionally independent, they both use the same data format and baud rate. In all cases stop bits will be used for data transmission.

### Enabling/Disabling the UART Interface

The basic on/off function of the internal UARTn function is controlled using the UARTEN<sub>n</sub> bit in the UnCR1 register. If the UARTEN<sub>n</sub>, TXEN<sub>n</sub> and RXEN<sub>n</sub> bits are set, then these two UARTn pins will act as normal TX<sub>n</sub> output pin and RX<sub>n</sub> input pin respectively. If no data is being transmitted on the TX<sub>n</sub> pin, then it will default to a logic high value.

Clearing the UARTEN<sub>n</sub> bit will disable the TX<sub>n</sub> and RX<sub>n</sub> pins and then these two pins can be used as an I/O or other pin-shared functional pins by properly configurations. When the UARTn function is disabled, the buffer will be reset to an empty condition, at the same time discarding any remaining residual data. Disabling the UARTn will also reset the enable control, the error and status flags with bits TXEN<sub>n</sub>, RXEN<sub>n</sub>, TXBRK<sub>n</sub>, RXIF<sub>n</sub>, OERR<sub>n</sub>, FERR<sub>n</sub>, PERR<sub>n</sub> and NFN being cleared while bits TIDLE<sub>n</sub>, TXIF<sub>n</sub> and RIDLE<sub>n</sub> will be set. The remaining control bits in the UnCR1, UnCR2 and BRG<sub>n</sub> registers will remain unaffected. If the UARTEN<sub>n</sub> bit in the UnCR1 register is cleared while the UARTn is active, then all pending transmissions and receptions will be immediately suspended and the UARTn will be reset to a condition as defined above. If the UARTn is then subsequently re-enabled, it will restart again in the same configuration.

### Data, Parity and Stop Bit Selection

The format of the data to be transferred is composed of various factors such as data bit length, parity on/off, parity type, address bits and the number of stop bits. These factors are determined by the setup of various bits within the UnCR1 register. The BNO<sub>n</sub> bit controls the number of data bits which can be set to either 8 or 9. The PRT<sub>n</sub> bit controls the choice if odd or even parity. The PREN<sub>n</sub> bit controls the parity on/off function. The STOPS<sub>n</sub> bit decides whether one or two stop bits are to be used. The following table shows various formats for data transmission. The address bit, which is the MSB of the data byte, identifies the frame as an address character or data if the address detect function is enabled. The number of stop bits, which can be either one or two, is independent of the data length.

| Start Bit                            | Data Bits | Address Bits | Parity Bit | Stop Bit |
|--------------------------------------|-----------|--------------|------------|----------|
| <b>Example of 8-bit Data Formats</b> |           |              |            |          |
| 1                                    | 8         | 0            | 0          | 1        |
| 1                                    | 7         | 0            | 1          | 1        |
| 1                                    | 7         | 1            | 0          | 1        |
| <b>Example of 9-bit Data Formats</b> |           |              |            |          |
| 1                                    | 9         | 0            | 0          | 1        |
| 1                                    | 8         | 0            | 1          | 1        |
| 1                                    | 8         | 1            | 0          | 1        |

**Transmitter Receiver Data Format**

The following diagram shows the transmit and receive waveforms for both 8-bit and 9-bit data formats.

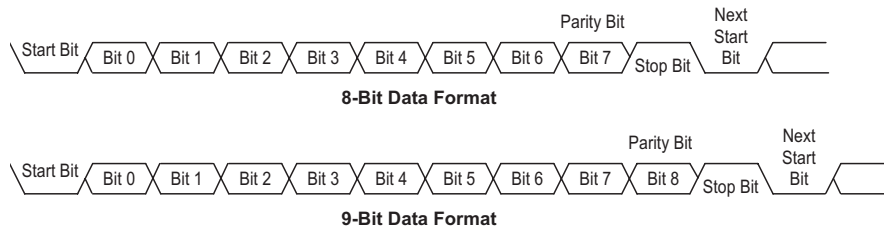

## UART Transmitter

Data word lengths of either 8 or 9 bits can be selected by programming the BNO<sub>n</sub> bit in the UnCR1 register. When BNO<sub>n</sub> bit is set, the word length will be set to 9 bits. In this case the 9<sup>th</sup> bit, which is the MSB, needs to be stored in the TX8<sub>n</sub> bit in the UnCR1 register. At the transmitter core lies the Transmitter Shift Register, more commonly known as the TSR<sub>n</sub>, whose data is obtained from the transmit data register, which is known as the TXR\_RXR<sub>n</sub> register. The data to be transmitted is loaded into this TXR\_RXR<sub>n</sub> register by the application program. The TSR<sub>n</sub> register is not written to with new data until the stop bit from the previous transmission has been sent out. As soon as this stop bit has been transmitted, the TSR<sub>n</sub> can then be loaded with new data from the TXR\_RXR<sub>n</sub> register, if it is available. It should be noted that the TSR<sub>n</sub> register, unlike many other registers, is not directly mapped into the Data Memory area and as such is not available to the application program for direct read/write operations. An actual transmission of data will normally be enabled when the TXEN<sub>n</sub> bit is set, but the data will not be transmitted until the TXR\_RXR<sub>n</sub> register has been loaded with data and the baud rate generator has defined a shift clock source. However, the transmission can also be initiated by first loading data into the TXR\_RXR<sub>n</sub> register, after which the TXEN<sub>n</sub> bit can be set. When a transmission of data begins, the TSR<sub>n</sub> is normally empty, in which case a transfer to the TXR\_RXR<sub>n</sub> register will result in an immediate transfer to the TSR<sub>n</sub>. If during a transmission the TXEN<sub>n</sub> bit is cleared, the transmission will immediately cease and the transmitter will be reset. The TX<sub>n</sub> output pin can then return to the I/O or other pin-shared function by properly configurations.

## Transmitting Data

When the UART<sub>n</sub> is transmitting data, the data is shifted on the TX<sub>n</sub> pin from the shift register, with the least significant bit LSB first. In the transmit mode, the TXR\_RXR<sub>n</sub> register forms a buffer between the internal bus and the transmitter shift register. It should be noted that if 9-bit data format has been selected, then the MSB will be taken from the TX8<sub>n</sub> bit in the UnCR1 register. The steps to initiate a data transfer can be summarized as follows:

- Make the correct selection of the BNO<sub>n</sub>, PRT<sub>n</sub>, PREN<sub>n</sub> and STOPS<sub>n</sub> bits to define the required word length, parity type and number of stop bits.
- Setup the BRG<sub>n</sub> register to select the desired baud rate.
- Set the TXEN<sub>n</sub> bit to ensure that the UART<sub>n</sub> transmitter is enabled and the TX<sub>n</sub> pin is used as a UART<sub>n</sub> transmitter pin.
- Access the UnSR register and write the data that is to be transmitted into the TXR\_RXR<sub>n</sub> register. Note that this step will clear the TXIF<sub>n</sub> bit.

This sequence of events can now be repeated to send additional data. It should be noted that when TXIFn=0, data will be inhibited from being written to the TXR\_RXRn register. Clearing the TXIFn flag is always achieved using the following software sequence:

1. A UnSR register access
2. A TXR\_RXRn register write execution

The read-only TXIFn flag is set by the UARTn hardware and if set indicates that the TXR\_RXRn register is empty and that other data can now be written into the TXR\_RXRn register without overwriting the previous data. If the TEIEEn bit is set, then the TXIFn flag will generate an interrupt. During a data transmission, a write instruction to the TXR\_RXRn register will place the data into the TXR\_RXRn register, which will be copied to the shift register at the end of the present transmission. When there is no data transmission in progress, a write instruction to the TXR\_RXRn register will place the data directly into the shift register, resulting in the commencement of data transmission, and the TXIFn bit being immediately set. When a frame transmission is complete, which happens after stop bits are sent or after the break frame, the TIDLEn bit will be set. To clear the TIDLEn bit the following software sequence is used:

1. A UnSR register access
2. A TXR\_RXRn register write execution

Note that both the TXIFn and TIDLEn bits are cleared by the same software sequence.

### Transmitting Break

If the TXBRKn bit is set, then the break characters will be sent on the next transmission. Break character transmission consists of a start bit, followed by 13xN "0" bits, where N=1, 2, etc. If a break character is to be transmitted, then the TXBRKn bit must be first set by the application program and then cleared to generate the stop bits. Transmitting a break character will not generate a transmit interrupt. Note that a break condition length is at least 13 bits long. If the TXBRKn bit is continually kept at a logic high level, then the transmitter circuitry will transmit continuous break characters. After the application program has cleared the TXBRKn bit, the transmitter will finish transmitting the last break character and subsequently send out one or two stop bits. The automatic logic high at the end of the last break character will ensure that the start bit of the next frame is recognized.

### UART Receiver

The UARTn is capable of receiving word lengths of either 8 or 9 bits can be selected by programming the BNOEn bit in the UnCR1 register. When BNOEn bit is set, the word length will be set to 9 bits. In this case the 9<sup>th</sup> bit, which is the MSB, will be stored in the RX8n bit in the UnCR1 register. At the receiver core lies the Receiver Shift Register more commonly known as the RSRn. The data which is received on the RXn external input pin is sent to the data recovery block. The data recovery block operating speed is 16 times that of the baud rate, while the main receive serial shifter operates at the baud rate. After the RXn pin is sampled for the stop bit, the received data in RSRn is transferred to the receive data register, if the register is empty. The data which is received on the external RXn input pin is sampled three times by a majority detect circuit to determine the logic level that has been placed onto the RXn pin. It should be noted that the RSRn register, unlike many other registers, is not directly mapped into the Data Memory area and as such is not available to the application program for direct read/write operations.

### Receiving Data

When the UARTn receiver is receiving data, the data is serially shifted in on the external RXn input pin to the shift register, with the least significant bit LSB first. The TXR\_RXRn register is a two byte deep FIFO data buffer, where two bytes can be held in the FIFO while the 3<sup>rd</sup> byte can continue to be received. Note that the application program must ensure that the data is read from TXR\_RXRn before the 3<sup>rd</sup> byte has been completely shifted in, otherwise the 3<sup>rd</sup> byte will be discarded and an overrun error OERRn will be subsequently indicated. The steps to initiate a data transfer can be summarized as follows:

- Make the correct selection of the BNO<sub>n</sub>, PRT<sub>n</sub>, PREN<sub>n</sub> and STOPS<sub>n</sub> bits to define the required word length, parity type and number of stop bits.
- Setup the BRG<sub>n</sub> register to select the desired baud rate.
- Set the RXEN<sub>n</sub> bit to ensure that the UARTn receiver is enabled and the RXn pin is used as a UARTn receiver pin.

At this point the receiver will be enabled which will begin to look for a start bit.

When a character is received, the following sequence of events will occur:

- The RXIF<sub>n</sub> bit in the UnSR register will be set when the TXR\_RXRn register has data available. There will be at most one more character that can be read.
- When the contents of the shift register have been transferred to the TXR\_RXRn register and if the RIEN bit is set, then an interrupt will be generated.
- If during reception, a frame error, noise error, parity error or an overrun error has been detected, then the error flags can be set.

The RXIF<sub>n</sub> bit can be cleared using the following software sequence:

1. A UnSR register access
2. A TXR\_RXRn register read execution

### Receiving Break

Any break character received by the UARTn will be managed as a framing error. The receiver will count and expect a certain number of bit times as specified by the values programmed into the BNO<sub>n</sub> and STOPS<sub>n</sub> bits. If the break is much longer than 13 bit times, the reception will be considered as complete after the number of bit times specified by BNO<sub>n</sub> and STOPS<sub>n</sub>. The RXIF<sub>n</sub> bit is set, FERR<sub>n</sub> is set, zeros are loaded into the receive data register, interrupts are generated if appropriate and the RIDLE<sub>n</sub> bit is set. A break is regarded as a character that contains only zeros with the FERR<sub>n</sub> flag being set. If a long break signal has been detected, the receiver will regard it as a data frame including a start bit, data bits and the invalid stop bit and the FERR<sub>n</sub> flag will be set. The receiver must wait for a valid stop bit before looking for the next start bit. The receiver will not make the assumption that the break condition on the line is the next start bit. The break character will be loaded into the buffer and no further data will be received until stop bits are received. It should be noted that the RIDLE<sub>n</sub> read only flag will go high when the stop bits have not yet been received. The reception of a break character on the UARTn registers will result in the following:

- The framing error flag, FERR<sub>n</sub>, will be set.
- The receive data register, TXR\_RXRn, will be cleared.
- The OERR<sub>n</sub>, NF<sub>n</sub>, PERR<sub>n</sub>, RIDLE<sub>n</sub> or RXIF<sub>n</sub> flags will possibly be set.

### Idle Status

When the receiver is reading data, which means it will be in between the detection of a start bit and the reading of a stop bit, the receiver status flag in the UnSR register, otherwise known as the RIDLEn flag, will have a zero value. In between the reception of a stop bit and the detection of the next start bit, the RIDLEn flag will have a high value, which indicates the receiver is in an idle condition.

### Receiver Interrupt

The read only receive interrupt flag, RXIFn, in the UnSR register is set by an edge generated by the receiver. An interrupt is generated if RIEn=1, when a word is transferred from the Receive Shift Register, RSRn, to the Receive Data Register, TXR\_RXRn. An overrun error can also generate an interrupt if RIEn=1.

## Managing Receiver Errors

Several types of reception errors can occur within the UARTn module, the following section describes the various types and how they are managed by the UARTn.

### Overrun Error – OERRn

The TXR\_RXRn register is composed of a two byte deep FIFO data buffer, where two bytes can be held in the FIFO register, while a 3<sup>th</sup> byte can continue to be received. Before the 3<sup>th</sup> byte has been entirely shifted in, the data should be read from the TXR\_RXRn register. If this is not done, the overrun error flag OERRn will be consequently indicated.

In the event of an overrun error occurring, the following will happen:

- The OERRn flag in the UnSR register will be set.
- The TXR\_RXRn contents will not be lost.
- The shift register will be overwritten.
- An interrupt will be generated if the RIEn bit is set.

The OERRn flag can be cleared by an access to the UnSR register followed by a read to the TXR\_RXRn register.

### Noise Error – NFn

Over-sampling is used for data recovery to identify valid incoming data and noise. If noise is detected within a frame, the following will occur:

- The read only noise flag, NFn, in the UnSR register will be set on the rising edge of the RXIFn bit.
- Data will be transferred from the shift register to the TXR\_RXRn register.
- No interrupt will be generated. However this bit rises at the same time as the RXIFn bit which itself generates an interrupt.

Note that the NFn flag is reset by an UnSR register read operation followed by a TXR\_RXRn register read operation.

### Framing Error – FERRn

The read only framing error flag, FERRn, in the UnSR register, is set if a zero is detected instead of stop bits. If two stop bits are selected, both stop bits must be high. Otherwise the FERRn flag will be set. The FERRn flag and the received data will be recorded in the UnSR and TXR\_RXRn registers respectively and the FERRn flag will be cleared in any reset.

### Parity Error – PERRn

The read only parity error flag, PERRn, in the UnSR register, is set if the parity of the received word is incorrect. This error flag is only applicable if the parity function is enabled, PRENn=1, and if the parity type, odd or even, is selected. The read only PERRn flag and the received data will be recorded in the UnSR and TXR\_RXRn registers respectively and the flag will be cleared on any reset. It should be noted that the FERRn and PERRn flags in the UnSR register should first be read by the application programs before reading the data word.

### UART Interrupt Structure

Several individual UARTn conditions can generate a UARTn interrupt. When these conditions exist, a low pulse will be generated to get the attention of the microcontroller. These conditions are a transmitter data register empty, transmitter idle, receiver data available, receiver overrun, address detect and an RXn pin wake-up. When any of these conditions are created, if its corresponding interrupt control is enabled and the stack is not full, the program will jump to its corresponding interrupt vector where it can be serviced before returning to the main program. Four of these conditions have the corresponding UnSR register flags which will generate a UARTn interrupt if its associated interrupt enable control bit in the UnCR2 register is set. The two transmitter interrupt conditions have their own corresponding enable control bits, while the two receiver interrupt conditions have a shared enable control bit. These enable bits can be used to mask out individual UARTn interrupt sources.

The address detect condition, which is also a UARTn interrupt source, does not have an associated flag, but will generate a UARTn interrupt when an address detect condition occurs if its function is enabled by setting the ADDENn bit in the UnCR2 register. An RXn pin wake-up, which is also a UARTn interrupt source, does not have an associated flag, but will generate a UARTn interrupt if the UARTn clock source, f<sub>H</sub>, is switched off and the WAKEn and RIEn bits in the UnCR2 register are set when a falling edge on the RXn pin occurs. Note that in the event of an RXn wake-up interrupt occurring, there will be a certain period of delay, commonly known as the System Start-up Time, for the oscillator to restart and stabilize before the system resumes normal operation.

Note that the UnSR register flags are read only and cannot be cleared or set by the application program, neither will they be cleared when the program jumps to the corresponding interrupt servicing routine, as is the case for some of the other interrupts. The flags will be cleared automatically when certain actions are taken by the UARTn, the details of which are given in the UARTn register section. The overall UARTn interrupt can be disabled or enabled by the related interrupt enable control bits in the interrupt control registers of the microcontroller to decide whether the interrupt requested by the UARTn module is masked out or allowed.

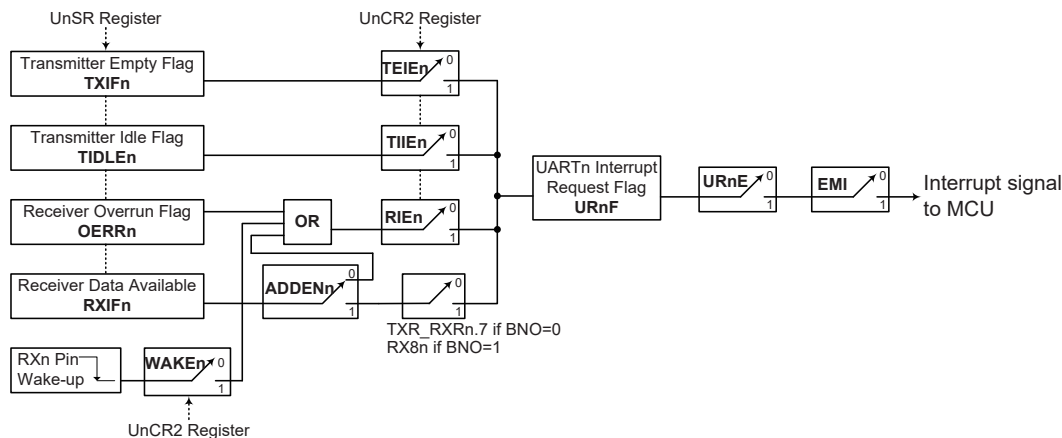

**UARTn Interrupt Structure**

### Address Detect Mode

Setting the Address Detect function enable control bit, ADDENn, in the UnCR2 register, enables this special function. If this bit is set to 1, then an additional qualifier will be placed on the generation of a Receiver Data Available interrupt, which is requested by the RXIFn flag. If the ADDENn bit is equal to 1, then when the data is available, an interrupt will only be generated, if the highest received bit has a high value. Note that the related interrupt enable control bit and the EMI bit of the microcontroller must also be enabled for correct interrupt generation. The highest address bit is the 9<sup>th</sup> bit if the bit BNO<sub>n</sub>=1 or the 8<sup>th</sup> bit if the bit BNO<sub>n</sub>=0. If the highest bit is high, then the received word will be defined as an address rather than data. A Data Available interrupt will be generated every time the last bit of the received word is set. If the ADDENn bit is equal to 0, then a Receive Data Available interrupt will be generated each time the RXIFn flag is set, irrespective of the data last bit status. The address detection and parity functions are mutually exclusive functions. Therefore, if the address detect function is enabled, then to ensure correct operation, the parity function should be disabled by resetting the parity function enable bit PRENn to zero.

| ADDENn | Bit 9 if BNO <sub>n</sub> =1<br>Bit 8 if BNO <sub>n</sub> =0 | UARTn Interrupt<br>Generated |
|--------|--|------------------------------|
| 0      | 0  | √                            |
|        | 1  | √                            |
| 1      | 0  | X                            |
|        | 1  | √                            |

**ADDENn Bit Function**

### UART Power Down and Wake-up

When the UARTn clock,  $f_{Hn}$ , is switched off, the UARTn will cease to function. If the MCU switches off the UARTn clock  $f_{Hn}$  and enters the power down mode while a transmission is still in progress, then the transmission will be paused until the UARTn clock source derived from the microcontroller is activated. In a similar way, if the MCU switches off the UART clock  $f_{Hn}$  and enters the power down mode by executing the "HALT" instruction while receiving data, then the reception of data will likewise be paused. When the MCU enters the power down mode, note that the UnSR, UnCR1, UnCR2, transmit and receive registers, as well as the BRGn register will not be affected. It is recommended to make sure first that the UARTn data transmission or reception has been finished before the microcontroller enters the power down mode.

The UARTn function contains a receiver RXn pin wake-up function, which is enabled or disabled by the WAKEn bit in the UnCR2 register. If this bit, along with the UARTn enable bit, UARTENn, the receiver enable bit, RXENn and the receiver interrupt bit, RIEn, are all set before the MCU enters the power down mode with the UARTn clock  $f_{Hn}$  being switched off, then a falling edge on the RXn pin will initiate a RXn pin wake-up UARTn interrupt. Note that as it takes certain system clock cycles after a wake-up, before normal microcontroller operation resumes, any data received during this time on the RXn pin will be ignored.

For a UARTn wake-up interrupt to occur, in addition to the bits for the wake-up being set, the global interrupt enable bit, EMI, and the UARTn interrupt enable bit, URnE, must be set. If the EMI and URnE bits are not set then only a wake up event will occur and no interrupt will be generated. Note also that as it takes certain system clock cycles after a wake-up before normal microcontroller resumes, the UARTn interrupt will not be generated until after this time has elapsed.

## Comparators

Two independent analog comparators are contained in these devices. The comparator functions offer flexibility via their register controlled features such as power-down, polarity select, response time, etc. In sharing their pins with normal I/O pins the comparators do not waste precious I/O pins if the comparator functions are otherwise unused.

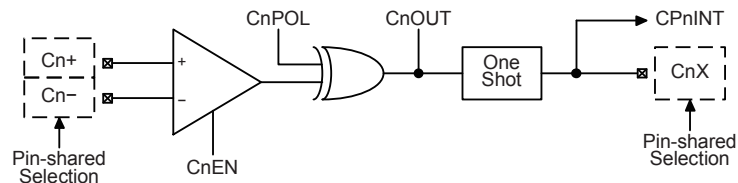

Comparators (n=0~1)

### Comparator Operation

The devices contain two comparator functions which are used to compare two analog voltages and provide an output based on their difference. Full control over the two internal comparators is provided via the control register, CP0C and CP1C, one assigned to each comparator. The comparator output is recorded via a bit in the control register, but can also be transferred out onto a shared I/O pin. Additional comparator functions include output polarity, response time and power down control.

Any pull-high resistors connected to the shared comparator input pins will be automatically disconnected when the comparator is enabled. As the comparator inputs approach their switching level, some spurious output signals may be generated on the comparator output due to the slow rising or falling nature of the input signals. This can be minimised by the hysteresis function which will apply a small amount of positive feedback to the comparator. When the comparator operates in the normal mode, the hysteresis function will automatically be enabled. However, the hysteresis function will be disabled when the comparator operates in the input offset calibration mode.

Ideally the comparator should switch at the point where the positive and negative inputs signals are at the same voltage level. However, unavoidable input offsets introduce some uncertainties here. The offset calibration function, if executed, will minimise the switching offset value. The comparator also provides the output response time select function using the CNVTn1~CNVTn0 bits in the CPnC register.

### Comparator Registers

There are four registers for overall comparator operation, two registers, CPnC and CPnVOS, for each comparator. As corresponding bits in these registers have identical functions, the following register table applies to the registers.

| Register Name | Bit |       |       |       |        |        |       |       |
|---------------|-----|-------|-------|-------|--------|--------|-------|-------|
|               | 7   | 6     | 5     | 4     | 3      | 2      | 1     | 0     |
| CPnC          | —   | CnEN  | CnPOL | CnOUT | CNVTn1 | CNVTn0 | —     | —     |
| CPnVOS        | —   | CnOFM | CnRSP | CnOF4 | CnOF3  | CnOF2  | CnOF1 | CnOF0 |

Comparator Registers List (n=0~1)

• **CPnC Register**

| Bit  | 7 | 6    | 5     | 4     | 3      | 2      | 1 | 0 |
|------|---|------|-------|-------|--------|--------|---|---|
| Name | — | CnEN | CnPOL | CnOUT | CNVtn1 | CNVtn0 | — | — |
| R/W  | — | R/W  | R/W   | R     | R/W    | R/W    | — | — |
| POR  | — | 0    | 0     | 0     | 0      | 0      | — | — |

- Bit 7 Unimplemented, read as "0"
- Bit 6 **CnEN**: Comparator enable control  
 0: Disable  
 1: Enable  
 This bit is used to enable the comparator function. If this bit is cleared to zero, the comparator will be switched off and no power consumed even if analog voltages are applied to its inputs. When the comparator function is disabled, the comparator output will be set to zero.
- Bit 5 **CnPOL**: Comparator output polarity selection  
 0: Output not inverted  
 1: Output inverted  
 If this bit is cleared to zero, the CnOUT bit will reflect the non-inverted output condition of the comparator. If this bit is set high, the CnOUT bit will be inverted.
- Bit 4 **CnOUT**: Comparator output bit  
 CnPOL=0  
 0: Cn+ < Cn-  
 1: Cn+ > Cn-  
 CnPOL=1  
 0: Cn+ > Cn-  
 1: Cn+ < Cn-  
 This bit is used to store the comparator output bit. The polarity of this bit is determined by the voltages on the comparator inputs and by the condition of the CnPOL bit.
- Bit 3~2 **CNVtn1~CNVTn0**: Comparator response time selection  
 00: Response time 0 (max.)  
 01: Response time 1  
 10: Response time 2  
 11: Response time 3 (min.)  
 These bits are used to select the comparator response time. The detailed response time specifications are listed in the Comparator Characteristics.
- Bit 1~0 Unimplemented, read as "0"

• **CPnVOS Register**

| Bit  | 7 | 6     | 5     | 4     | 3     | 2     | 1     | 0     |
|------|---|-------|-------|-------|-------|-------|-------|-------|
| Name | — | CnOFM | CnRSP | CnOF4 | CnOF3 | CnOF2 | CnOF1 | CnOF0 |
| R/W  | — | R/W   | R/W   | R/W   | R/W   | R/W   | R/W   | R/W   |
| POR  | — | 0     | 0     | 1     | 0     | 0     | 0     | 0     |

- Bit 7 Unimplemented, read as "0"
- Bit 6 **CnOFM**: Comparator normal operation or input offset calibration mode selection  
 0: Normal operation mode  
 1: Input offset calibration mode  
 This bit is used to enable the comparator input offset calibration function. Refer to the "Input Offset Calibration" section for the detailed input offset calibration procedures.

- Bit 5      **CnRSP**: Comparator input offset calibration reference input selection  
            0: Cn- is selected as reference input  
            1: Cn+ is selected as reference input
- Bit 4~0    **CnOF4~CnOF0**: Comparator input offset calibration value  
            This 5-bit field is used to perform the comparator input offset calibration operation and the value after the input offset calibration can be restored into this bit field. Refer to the "Input Offset Calibration" section for more detailed information.

### Input Offset Calibration

To operate in the input offset calibration mode, the comparator input pins to be used should first be selected by properly configuring the corresponding pin-shared function selection bits followed by setting the CnOFM bit high. The procedure is described in the following.

Step 1. Set CnOFM=1 to enable the comparator input offset calibration mode.

Step 2. Set CnOF [4:0]=00000 and read the CnOUT bit.

Step 3. Increase the CnOF [4:0] value by 1 and then read the CnOUT bit.

If the CnOUT bit state does not changed, then repeat Step 3 until the CnOUT bit state changes.

If the CnOUT bit state changes, record the CnOF field value as VCnOS1 and then go to Step 4.

Step 4. Set CnOF [4:0]=11111 and read the CnOUT bit.

Step 5. Decrease the CnOF [4:0] value by 1 and then read the CnOUT bit.

If the CnOUT bit state does not changed, then repeat Step 5 until the CnOUT bit state changes.

If the CnOUT bit state changes, record the CnOF field value as VCnOS2 and then go to Step 6.

Step 6. Restore the comparator input offset calibration value VCnOS into the CnOF [4:0] bit field.

The offset calibration procedure is now finished.

$$\text{Where } VCnOS = \frac{VCnOS1 + VCnOS2}{2}$$

### Comparator Interrupt

The comparator possesses its own interrupt function. When the comparator output changes state, its relevant interrupt flag will be set, and if the corresponding interrupt enable bit is set, then a jump to its relevant interrupt vector will be executed. Note that it is the changing state of the CnOUT bit and not the output pin which generates an interrupt. If the microcontroller is in the SLEEP or IDLE Mode and the Comparator is enabled, then if the external input lines cause the Comparator output to change state, the resulting generated interrupt flag will also generate a wake-up. If it is required to disable a wake-up from occurring, then the interrupt flag should be first set high before entering the SLEEP or IDLE Mode.

### Programming Considerations

If the comparator is enabled, it will remain active when the microcontroller enters the SLEEP or IDLE Mode, however as it will consume a certain amount of power, the user may wish to consider disabling it before the SLEEP or IDLE Mode is entered. As comparator pins are shared with normal I/O pins the I/O data bits for these pins will be read as zero regardless of the port control register bit value due to normal I/O path being switched off if the comparator function is enabled.

## Software Controlled LCD Driver

The devices have the capability of driving external LCD panels. The common pins, SCOM0~SCOM3, for LCD driving are pin-shared with certain pins on the I/O ports. The LCD signals (COM) are generated using the application program.

### LCD Operation

An external LCD panel can be driven using the devices by configuring the I/O pins as common pins. The LCD driver function is controlled using the LCD control registers which in addition to controlling the overall on/off function also controls the R-type bias current on the SCOMn pins. This enables the LCD COM driver to generate the necessary voltage levels,  $V_{SS}$ ,  $V_{DD}/2$  and  $V_{DD}$ , for LCD 1/2 bias operation.

The SCOMEN bit in the SCOMC register is the overall master control for the LCD driver. The SCOMn pin is selected to be used for LCD driving by the corresponding pin-shared function selection bits. Note that the corresponding Port Control register does not need to first setup the pins as outputs to enable the LCD driver operation.

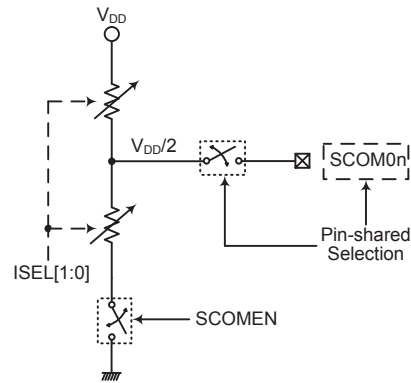

**Software Controlled LCD Driver Structure**

## LCD Bias Current Control

The LCD COM driver enables a range of selections to be provided to suit the requirement of the LCD panel which is being used. The bias current choice is implemented using the ISEL1 and ISEL0 bits in the SCOMC register. All COM pins are pin-shared with I/O pins and selected as SCOM pins using the corresponding pin-shared function selection bits.

### • SCOMC Register

| Bit  | 7 | 6     | 5     | 4      | 3 | 2 | 1 | 0 |
|------|---|-------|-------|--------|---|---|---|---|
| Name | — | ISEL1 | ISEL0 | SCOMEN | — | — | — | — |
| R/W  | — | R/W   | R/W   | R/W    | — | — | — | — |
| POR  | — | 0     | 0     | 0      | — | — | — | — |

Bit 7 Unimplemented, read as "0"

Bit 6~5 **ISEL1~ISEL0**: SCOM typical bias current selection (@ $V_{DD}=5V$ )  
 00: 25 $\mu$ A  
 01: 50 $\mu$ A  
 10: 100 $\mu$ A  
 11: 200 $\mu$ A

Bit 4 **SCOMEN**: Software controlled LCD Driver enable control  
 0: Disable  
 1: Enable

The SCOMn lines can be enabled using the corresponding pin-shared selection bits if the SCOMEN bit is set to 1. When the SCOMEN bit is cleared to 0, then the SCOMn outputs will be fixed at a  $V_{DD}$  level. Note that the corresponding pin-shared selection bits should first be properly configured before the SCOMn function is enabled.

Bit 3~0 Unimplemented, read as "0"

## 16-bit Multiplication Division Unit – MDU

The devices each has a 16-bit Multiplication Division Unit, MDU, which integrates a 16-bit unsigned multiplier and a 32-bit/16-bit divider. The MDU, in replacing the software multiplication and division operations, can therefore save large amounts of computing time as well as the Program and Data Memory space. It also reduces the overall microcontroller loading and results in the overall system performance improvements.

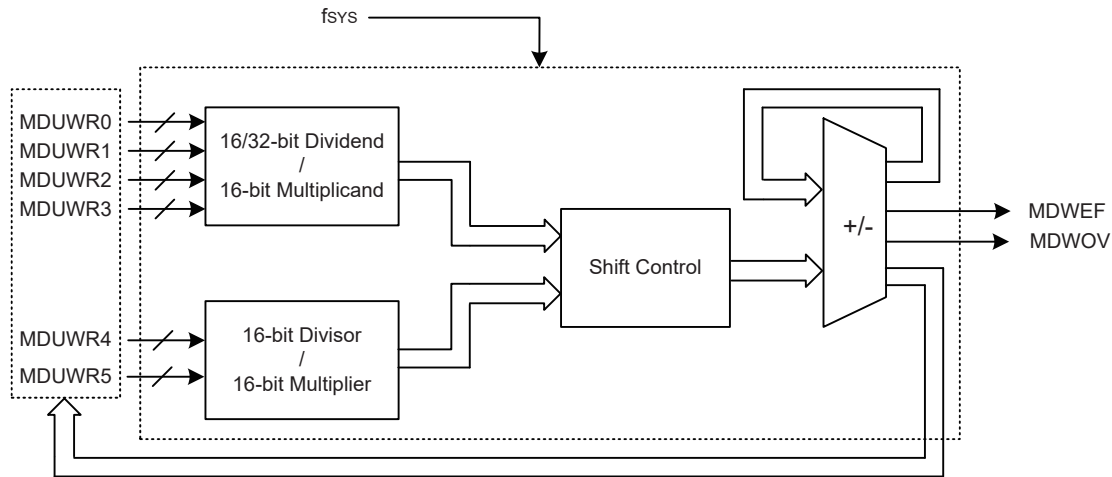

**16-Bit MDU Block Diagram**

### MDU Registers

The multiplication and division operations are implemented in a specific way, a specific write access sequence of a series of MDU data registers. The status register, MDUWCTRL, provides the indications for the MDU operation. The data register each is used to store the data regarded as the different operand corresponding to different MDU operations.

| Register Name | Bit   |       |    |    |    |    |    |    |
|---------------|-------|-------|----|----|----|----|----|----|
|               | 7     | 6     | 5  | 4  | 3  | 2  | 1  | 0  |
| MDUWR0        | D7    | D6    | D5 | D4 | D3 | D2 | D1 | D0 |
| MDUWR1        | D7    | D6    | D5 | D4 | D3 | D2 | D1 | D0 |
| MDUWR2        | D7    | D6    | D5 | D4 | D3 | D2 | D1 | D0 |
| MDUWR3        | D7    | D6    | D5 | D4 | D3 | D2 | D1 | D0 |
| MDUWR4        | D7    | D6    | D5 | D4 | D3 | D2 | D1 | D0 |
| MDUWR5        | D7    | D6    | D5 | D4 | D3 | D2 | D1 | D0 |
| MDUWCTRL      | MDWEF | MDWOV | —  | —  | —  | —  | —  | —  |

**MDU Registers List**

- **MDUWRn Register (n=0~5)**

| Bit  | 7   | 6   | 5   | 4   | 3   | 2   | 1   | 0   |
|------|-----|-----|-----|-----|-----|-----|-----|-----|
| Name | D7  | D6  | D5  | D4  | D3  | D2  | D1  | D0  |
| R/W  | R/W | R/W | R/W | R/W | R/W | R/W | R/W | R/W |
| POR  | x   | x   | x   | x   | x   | x   | x   | x   |

"x": unknown

Bit 7~0      **D7~D0**: 16-bit MDU data register n

• MDUWCTRL Register

| Bit  | 7     | 6     | 5 | 4 | 3 | 2 | 1 | 0 |
|------|-------|-------|---|---|---|---|---|---|
| Name | MDWEF | MDWOV | — | — | — | — | — | — |
| R/W  | R     | R     | — | — | — | — | — | — |
| POR  | 0     | 0     | — | — | — | — | — | — |

- Bit 7      **MDWEF**: 16-bit MDU error flag  
 0: Normal  
 1: Abnormal  
 This bit will be set to 1 if the data register MDUWRn is written or read as the MDU operation is executing. This bit should be cleared to 0 by reading the MDUWCTRL register if it is equal to 1 and the MDU operation is completed.
- Bit 6      **MDWOV**: 16-bit MDU overflow flag  
 0: No overflow occurs  
 1: Multiplication product > FFFFH or Divisor=0  
 When an operation is completed, this bit will be updated by hardware to a new value corresponding to the current operation situation.
- Bit 5~0    Unimplemented, read as "0"

**MDU Operation**

For this MDU the multiplication or division operation is carried out in a specific way and is determined by the write access sequence of the six MDU data registers, MDUWR0~MDUWR5. The low byte data, regardless of the dividend, multiplicand, divisor or multiplier, must first be written into the corresponding MDU data register followed by the high byte data. All MDU operations will be executed after the MDUWR5 register is write-accessed together with the correct specific write access sequence of the MDUWRn. Note that it is not necessary to consecutively write data into the MDU data registers but must be in a correct write access sequence. Therefore, a non-write MDUWRn instruction or an interrupt, etc., can be inserted into the correct write access sequence without destroying the write operation. The relationship between the write access sequence and the MDU operation is shown in the following.

- 32-bit/16-bit division operation: Write data sequentially into the six MDU data registers from MDUWR0 to MDUWR5.
- 16-bit/16-bit division operation: Write data sequentially into the specific four MDU data registers in a sequence of MDUWR0, MDUWR1, MDUWR4 and MDUWR5 with no write access to MDUWR2 and MDUWR3.
- 16-bit/16-bit multiplication operation: Write data sequentially into the specific four MDU data register in a sequence of MDUWR0, MDUWR4, MDUWR1 and MDUWR5 with no write access to MDUWR2 and MDUWR3.

After the specific write access sequence is determined, the MDU will start to perform the corresponding operation. The calculation time necessary for these MDU operations are different. During the calculation time any read/write access to the six MDU data registers is forbidden. After the completion of each operation, it is necessary to check the operation status in the MDUWCTRL register to make sure that whether the operation is correct or not. Then the operation result can be read out from the corresponding MDU data registers in a specific read access sequence if the operation is correctly finished. The necessary calculation time for different MDU operations is listed in the following.

- 32-bit/16-bit division operation:  $17 \times t_{SYS}$ .
- 16-bit/16-bit division operation:  $9 \times t_{SYS}$ .
- 16-bit/16-bit multiplication operation:  $11 \times t_{SYS}$ .

The operation results will be stored in the corresponding MDU data registers and should be read out from the MDU data registers in a specific read access sequence after the operation is completed. Note that it is not necessary to consecutively read data out from the MDU data registers but must be in a correct read access sequence. Therefore, a non-read MDUWRn instruction or an interrupt, etc., can be inserted into the correct read access sequence without destroying the read operation. The relationship between the operation result read access sequence and the MDU operation is shown in the following.

- 32-bit/16-bit division operation: Read the quotient from MDUWR0 to MDUWR3 and remainder from MDUWR4 and MDUWR5 sequentially.
- 16-bit/16-bit division operation: Read the quotient from MDUWR0 and MDUWR1 and remainder from MDUWR4 and MDUWR5 sequentially.
- 16-bit/16-bit multiplication operation: Read the product sequentially from MDUWR0 to MDUWR3.

The overall important points for the MDU read/write access sequence and calculation time are summarized in the following table.

| Operations<br>Items  | 32-bit / 16-bit Division   | 16-bit / 16-bit Division   | 16-bit × 16-bit Multiplication   |
|--|--|--|--|
| <b>Write Sequence</b><br>First write<br>↓<br>↓<br>↓<br>↓<br>Last write | Dividend Byte 0 written to MDUWR0<br>Dividend Byte 1 written to MDUWR1<br>Dividend Byte 2 written to MDUWR2<br>Dividend Byte 3 written to MDUWR3<br>Divisor Byte 0 written to MDUWR4<br>Divisor Byte 1 written to MDUWR5 | Dividend Byte 0 written to MDUWR0<br>Dividend Byte 1 written to MDUWR1<br>Divisor Byte 0 written to MDUWR4<br>Divisor Byte 1 written to MDUWR5 | Multiplicand Byte 0 written to MDUWR0<br>Multiplier Byte 0 written to MDUWR4<br>Multiplicand Byte 1 written to MDUWR1<br>Multiplier Byte 1 written to MDUWR5 |
| <b>Calculation Time</b>  | $17 \times t_{SYS}$  | $9 \times t_{SYS}$   | $11 \times t_{SYS}$  |
| <b>Read Sequence</b><br>First read<br>↓<br>↓<br>↓<br>↓<br>Last read    | Quotient Byte 0 read from MDUWR0<br>Quotient Byte 1 read from MDUWR1<br>Quotient Byte 2 read from MDUWR2<br>Quotient Byte 3 read from MDUWR3<br>Remainder Byte 0 read from MDUWR4<br>Remainder Byte 1 read from MDUWR5   | Quotient Byte 0 read from MDUWR0<br>Quotient Byte 1 read from MDUWR1<br>Remainder Byte 0 read from MDUWR4<br>Remainder Byte 1 read from MDUWR5 | Product Byte 0 read from MDUWR0<br>Product Byte 1 read from MDUWR1<br>Product Byte 2 read from MDUWR2<br>Product Byte 3 read from MDUWR3                     |

**MDU Operations Summary**

## Cyclic Redundancy Check – CRC

The Cyclic Redundancy Check, CRC, calculation unit is an error detection technique test algorithm and uses to verify data transmission or storage data correctness. A CRC calculation takes a data stream or a block of data as input and generates a 16-bit output remainder. Ordinarily, a data stream is suffixed by a CRC code and used as a checksum when being sent or stored. Therefore, the received or restored data stream is calculated by the same generator polynomial as described in the following section.

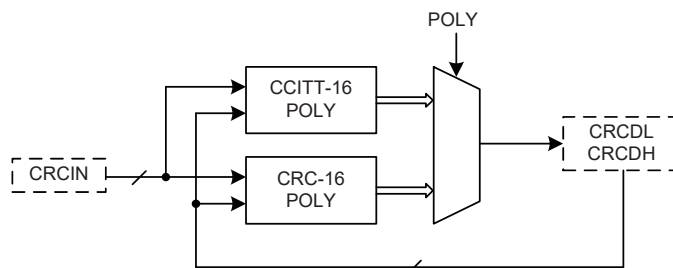

CRC Block Diagram

### CRC Registers

The CRC generator contains an 8-bit CRC data input register, CRCIN, and a CRC checksum register pair, CRCDH and CRCDL. The CRCIN register is used to input new data and the CRCDH and CRCDL registers are used to hold the previous CRC calculation result. A CRC control register, CRCCR, is used to select which CRC generating polynomial is used.

| Register Name | Bit |    |    |    |    |    |    |      |
|---------------|-----|----|----|----|----|----|----|------|
|               | 7   | 6  | 5  | 4  | 3  | 2  | 1  | 0    |
| CRCIN         | D7  | D6 | D5 | D4 | D3 | D2 | D1 | D0   |
| CRCDL         | D7  | D6 | D5 | D4 | D3 | D2 | D1 | D0   |
| CRCDH         | D7  | D6 | D5 | D4 | D3 | D2 | D1 | D0   |
| CRCCR         | —   | —  | —  | —  | —  | —  | —  | POLY |

CRC Registers List

- **CRCIN Register**

| Bit  | 7   | 6   | 5   | 4   | 3   | 2   | 1   | 0   |
|------|-----|-----|-----|-----|-----|-----|-----|-----|
| Name | D7  | D6  | D5  | D4  | D3  | D2  | D1  | D0  |
| R/W  | R/W | R/W | R/W | R/W | R/W | R/W | R/W | R/W |
| POR  | 0   | 0   | 0   | 0   | 0   | 0   | 0   | 0   |

Bit 7~0      **D7~D0**: CRC input data register

- **CRCDL Register**

| Bit  | 7   | 6   | 5   | 4   | 3   | 2   | 1   | 0   |
|------|-----|-----|-----|-----|-----|-----|-----|-----|
| Name | D7  | D6  | D5  | D4  | D3  | D2  | D1  | D0  |
| R/W  | R/W | R/W | R/W | R/W | R/W | R/W | R/W | R/W |
| POR  | 0   | 0   | 0   | 0   | 0   | 0   | 0   | 0   |

Bit 7~0      **D7~D0**: 16-bit CRC checksum low byte data register

• **CRCDH Register**

| Bit  | 7   | 6   | 5   | 4   | 3   | 2   | 1   | 0   |
|------|-----|-----|-----|-----|-----|-----|-----|-----|
| Name | D7  | D6  | D5  | D4  | D3  | D2  | D1  | D0  |
| R/W  | R/W | R/W | R/W | R/W | R/W | R/W | R/W | R/W |
| POR  | 0   | 0   | 0   | 0   | 0   | 0   | 0   | 0   |

Bit 7~0      **D7~D0**: 16-bit CRC checksum high byte data register

• **CRCCR Register**

| Bit  | 7 | 6 | 5 | 4 | 3 | 2 | 1 | 0    |
|------|---|---|---|---|---|---|---|------|
| Name | — | — | — | — | — | — | — | POLY |
| R/W  | — | — | — | — | — | — | — | R/W  |
| POR  | — | — | — | — | — | — | — | 0    |

Bit 7~1      Unimplemented, read as "0"

Bit 0      **POLY**: 16-bit CRC generating polynomial selection  
 0: CRC-CCITT:  $X^{16} + X^{12} + X^5 + 1$   
 1: CRC-16:  $X^{16} + X^{15} + X^2 + 1$

**CRC Operation**

The CRC generator provides the 16-bit CRC result calculation based on the CRC16 and CCITT CRC16 polynomials. In this CRC generator, there are only these two polynomials available for the numeric values calculation. It can not support the 16-bit CRC calculations based on any other polynomials.

The following two expressions can be used for the CRC generating polynomial which is determined using the POLY bit in the CRC control register, CRCCR. The CRC calculation result is called as the CRC checksum, CRCSUM, and stored in the CRC checksum register pair, CRCDH and CRCDL.

- CRC-CCITT:  $X^{16} + X^{12} + X^5 + 1$ .
- CRC-16:  $X^{16} + X^{15} + X^2 + 1$ .

**CRC Computation**

Each write operation to the CRCIN register creates a combination of the previous CRC value stored in the CRCDH and CRCDL registers and the new data input. The CRC unit calculates the CRC data register value is based on byte by byte. It will take one MCU instruction cycle to calculate the CRC checksum.

• **CRC Calculation Procedures:**

1. Clear the checksum register pair, CRCDH and CRCDL.
2. Execute an "Exclusive OR" operation with the 8-bit input data byte and the 16-bit CRCSUM high byte. The result is called the temporary CRCSUM.
3. Shift the temporary CRCSUM value left by one bit and move a "0" into the LSB.
4. Check the shifted temporary CRCSUM value after procedure 3.  
 If the MSB is 0, then this shifted temporary CRCSUM will be considered as a new temporary CRCSUM. Otherwise, execute an "Exclusive OR" operation with the shifted temporary CRCSUM in procedure 3 and a data "8005H". Then the operation result will be regarded as the new temporary CRCSUM.  
 Note that the data to be perform an "Exclusive OR" operation is "8005H" for the CRC-16 polynomial while for the CRC-CCITT polynomial the data is "1021H".
5. Repeat the procedure 3 ~ procedure 4 until all bits of the input data byte are completely calculated.
6. Repeat the procedure 2~ procedure 5 until all of the input data bytes are completely calculated. Then, the latest calculated result is the final CRC checksum, CRCSUM.

• **CRC Calculation Examples:**

- Write 1 byte input data into the CRCIN register and the corresponding CRC checksum are individually calculated as the following table shown.

| CRC Data Input<br>CRC Polynomial    | 00H   | 01H   | 02H   | 03H   | 04H   | 05H   | 06H   | 07H   |
|-------------------------------------|-------|-------|-------|-------|-------|-------|-------|-------|
| CRC-CCITT ( $X^{16}+X^{12}+X^5+1$ ) | 0000H | 1021H | 2042H | 3063H | 4084H | 50A5H | 60C6H | 70E7H |
| CRC-16 ( $X^{16}+X^{15}+X^2+1$ )    | 0000H | 8005H | 800FH | 000AH | 801BH | 001EH | 0014H | 8011H |

Note: The initial value of the CRC checksum register pair, CRCDH and CRCDL, is zero before each CRC input data is written into the CRCIN register.

- Write 4 bytes input data into the CRCIN register sequentially and the CRC checksum are sequentially listed in the following table.

| CRC Data Input<br>CRC Polynomial    | CRCIN=78H→56H→34H→12H                  |
|-------------------------------------|--|
| CRC-CCITT ( $X^{16}+X^{12}+X^5+1$ ) | (CRCDH, CRCDL)=FF9FH→BBC3H→A367H→D0FAH |
| CRC-16 ( $X^{16}+X^{15}+X^2+1$ )    | (CRCDH, CRCDL)=0110h→91F1h→F2DEh→5C43h |

Note: The initial value of the CRC checksum register pair, CRCDH and CRCDL, is zero before the sequential CRC data input operation.

• **Program Memory CRC Checksum Calculation Example:**

1. Clear the checksum register pair, CRCDH and CRCDL.
2. Select the CRC-CCITT or CRC-16 polynomial as the generating polynomial using the POLY bit in the CRCCR register.
3. Execute the table read instruction to read the program memory data value.
4. Write the table data low byte into the CRCIN register and execute the CRC calculation with the current CRCSUM value. Then a new CRCSUM result will be obtained and stored in the CRC checksum register pair, CRCDH and CRCDL.
5. Write the table data high byte into the CRCIN register and execute the CRC calculation with the current CRCSUM value. Then a new CRCSUM result will be obtained and stored in the CRC checksum register pair, CRCDH and CRCDL.
6. Repeat the procedure 3 ~ procedure 5 to read the next program memory data value and execute the CRC calculation until all program memory data are read followed by the sequential CRC calculation. Then the value in the CRC checksum register pair is the final CRC calculation result.

## Low Voltage Detector – LVD

Each device has a Low Voltage Detector function, also known as LVD. This enabled the device to monitor the power supply voltage,  $V_{DD}$ , and provide a warning signal should it fall below a certain level. This function may be especially useful in battery applications where the supply voltage will gradually reduce as the battery ages, as it allows an early warning battery low signal to be generated. The Low Voltage Detector also has the capability of generating an interrupt signal.

### LVD Register

The Low Voltage Detector function is controlled using a single register with the name LVDC. Three bits in this register, VLVD2~VLVD0, are used to select one of eight fixed voltages below which a low voltage condition will be determined. A low voltage condition is indicated when the LVDO bit is set. If the LVDO bit is low, this indicates that the  $V_{DD}$  voltage is above the preset low voltage value. The LVDEN bit is used to control the overall on/off function of the low voltage detector. Setting the bit high will enable the low voltage detector. Clearing the bit to zero will switch off the internal low voltage detector circuits. As the low voltage detector will consume a certain amount of power, it may be desirable to switch off the circuit when not in use, an important consideration in power sensitive battery powered applications.

#### • LVDC Register

| Bit  | 7 | 6 | 5    | 4     | 3     | 2     | 1     | 0     |
|------|---|---|------|-------|-------|-------|-------|-------|
| Name | — | — | LVDO | LVDEN | VBGEN | VLVD2 | VLVD1 | VLVD0 |
| R/W  | — | — | R    | R/W   | R/W   | R/W   | R/W   | R/W   |
| POR  | — | — | 0    | 0     | 0     | 0     | 0     | 0     |

- Bit 7~6      Unimplemented, read as "0"
- Bit 5      **LVDO**: LVD output flag  
             0: No Low Voltage Detected  
             1: Low Voltage Detected
- Bit 4      **LVDEN**: Low Voltage Detector Enable control  
             0: Disable  
             1: Enable
- Bit 3      **VBGEN**: Bandgap Voltage Output Enable control  
             0: Disable  
             1: Enable
- Bit 2~0    **VLVD2~VLVD0**: LVD Voltage selection  
             000: 2.0V  
             001: 2.2V  
             010: 2.4V  
             011: 2.7V  
             100: 3.0V  
             101: 3.3V  
             110: 3.6V  
             111: 4.0V

## LVD Operation

The Low Voltage Detector function operates by comparing the power supply voltage,  $V_{DD}$ , with a pre-specified voltage level stored in the LVDC register. This has a range of between 2.0V and 4.0V. When the power supply voltage,  $V_{DD}$ , falls below this pre-determined value, the LVDO bit will be set high indicating a low power supply voltage condition. The Low Voltage Detector function is supplied by a reference voltage which will be automatically enabled. When the device enters the SLEEP Mode, the low voltage detector will automatically be disabled even if the LVDEN bit is high. After enabling the Low Voltage Detector, a time delay  $t_{LVDS}$  should be allowed for the circuitry to stabilise before reading the LVDO bit. Note also that as the  $V_{DD}$  voltage may rise and fall rather slowly, at the voltage nears that of  $V_{LVD}$ , there may be multiple bit LVDO transitions.

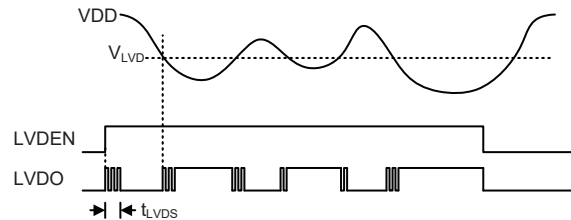

**LVD Operation**

The Low Voltage Detector also has its own interrupt which is contained within one of the Multi-function interrupts, providing an alternative means of low voltage detection, in addition to polling the LVDO bit. The interrupt will only be generated after a delay of  $t_{LVD}$  after the LVDO bit has been set high by a low voltage condition. When the device is powered down the Low Voltage Detector will remain active if the LVDEN bit is high. In this case, the LVF interrupt request flag will be set, causing an interrupt to be generated if  $V_{DD}$  falls below the preset LVD voltage. This will cause the device to wake-up from the IDLE Mode, however if the Low Voltage Detector wake up function is not required then the LVF flag should be first set high before the device enters the IDLE Mode.

## Interrupts

Interrupts are an important part of any microcontroller system. When an external event or an internal function such as a Timer Module or an A/D converter requires microcontroller attention, their corresponding interrupt will enforce a temporary suspension of the main program allowing the microcontroller to direct attention to their respective needs. These devices contain several external interrupt and internal interrupts functions. The external interrupts are generated by the action of the external INT0 ~ INT3 pins, while the internal interrupts are generated by various internal functions such as the TMs, Time Base, LVD, EEPROM, SIM, UART and the A/D converter, etc.

### Interrupt Registers

Overall interrupt control, which basically means the setting of request flags when certain microcontroller conditions occur and the setting of interrupt enable bits by the application program, is controlled by a series of registers, located in the Special Purpose Data Memory, as shown in the accompanying table. The number of registers depends upon the device chosen but fall into three categories. The first is the INTC0~INTC3 registers which setup the primary interrupts, the second is the MFI0~MFI5 registers which setup the Multi-function interrupts. Finally there is an INTEG register to setup the external interrupt trigger edge type.

Each register contains a number of enable bits to enable or disable individual interrupts as well as interrupt flags to indicate the presence of an interrupt request. The naming convention of these follows a specific pattern. First is listed an abbreviated interrupt type, then the (optional) number of that interrupt followed by either an "E" for enable/disable bit or "F" for request flag.

| Function               | Enable Bit | Request Flag | Notes  |
|------------------------|------------|--------------|--|
| Global                 | EMI        | —            | —  |
| INTn Pins              | INTnE      | INTnF        | n=0 ~ 3  |
| Comparator             | CPnE       | CPnF         | n=0 ~ 1  |
| A/D Converter          | ADE        | ADF          | —  |
| Time Base              | TBnE       | TBnF         | n=0 ~ 1  |
| Multi-function         | MFnE       | MFnF         | n=0 ~ 5  |
| UART                   | URnE       | URnF         | n=0 ~ 1 (HT66F2350/60)<br>n=0 ~ 2 (HT66F2370/90) |
| LVD                    | LVE        | LVF          | —  |
| EEPROM write operation | DEE        | DEF          | —  |
| SIM                    | SIME       | SIMF         | —  |
| SPIA                   | SPIAE      | SPIAF        | —  |
| PTM                    | PTMnPE     | PTMnPF       | n=0 ~ 3  |
|                        | PTMnAE     | PTMnAF       |  |
| STM                    | STMnPE     | STMnPF       | n=0 ~ 2  |
|                        | STMnAE     | STMnAF       |  |

**Interrupt Register Bit Naming Conventions**

| Register Name          | Bit    |        |        |        |        |        |        |        |
|------------------------|--------|--------|--------|--------|--------|--------|--------|--------|
|                        | 7      | 6      | 5      | 4      | 3      | 2      | 1      | 0      |
| INTEG                  | INT3S1 | INT3S0 | INT2S1 | INT2S0 | INT1S1 | INT1S0 | INT0S1 | INT0S0 |
| INTC0                  | —      | CP0F   | INT1F  | INT0F  | CP0E   | INT1E  | INT0E  | EMI    |
| INTC1                  | ADF    | MF1F   | MF0F   | CP1F   | ADE    | MF1E   | MF0E   | CP1E   |
| INTC2                  | MF3F   | TB1F   | TB0F   | MF2F   | MF3E   | TB1E   | TB0E   | MF2E   |
| INTC3                  | MF5F   | MF4F   | INT3F  | INT2F  | MF5E   | MF4E   | INT3E  | INT2E  |
| MF10                   | STM0AF | STM0PF | PTM0AF | PTM0PF | STM0AE | STM0PE | PTM0AE | PTM0PE |
| MF11                   | STM1AF | STM1PF | PTM1AF | PTM1PF | STM1AE | STM1PE | PTM1AE | PTM1PE |
| MF12                   | —      | —      | PTM2AF | PTM2PF | —      | —      | PTM2AE | PTM2PE |
| MF13                   | SIMF   | SPIAF  | DEF    | LVF    | SIME   | SPIAE  | DEE    | LVE    |
| MF14                   | STM2AF | STM2PF | PTM3AF | PTM3PF | STM2AE | STM2PE | PTM3AE | PTM3PE |
| MF15<br>(HT66F2350/60) | —      | —      | UR1F   | UR0F   | —      | —      | UR1E   | UR0E   |
| MF15<br>(HT66F2370/90) | —      | UR2F   | UR1F   | UR0F   | —      | UR2E   | UR1E   | UR0E   |

**Interrupt Registers List**

• **INTEG Register**

| Bit  | 7      | 6      | 5      | 4      | 3      | 2      | 1      | 0      |
|------|--------|--------|--------|--------|--------|--------|--------|--------|
| Name | INT3S1 | INT3S0 | INT2S1 | INT2S0 | INT1S1 | INT1S0 | INT0S1 | INT0S0 |
| R/W  | R/W    | R/W    | R/W    | R/W    | R/W    | R/W    | R/W    | R/W    |
| POR  | 0      | 0      | 0      | 0      | 0      | 0      | 0      | 0      |

Bit 7~6 **INT3S1~INT3S0**: Interrupt edge control for INT3 pin

- 00: Disable
- 01: Rising edge
- 10: Falling edge
- 11: Rising and falling edges

Bit 5~4 **INT2S1~INT2S0**: Interrupt edge control for INT2 pin

- 00: Disable
- 01: Rising edge
- 10: Falling edge
- 11: Rising and falling edges

Bit 3~2 **INT1S1~INT1S0**: Interrupt edge control for INT1 pin

- 00: Disable
- 01: Rising edge
- 10: Falling edge
- 11: Rising and falling edges

Bit 1~0 **INT0S1~INT0S0**: Interrupt edge control for INT0 pin

- 00: Disable
- 01: Rising edge
- 10: Falling edge
- 11: Rising and falling edges

• **INTC0 Register**

| Bit  | 7 | 6    | 5     | 4     | 3    | 2     | 1     | 0   |
|------|---|------|-------|-------|------|-------|-------|-----|
| Name | — | CP0F | INT1F | INT0F | CP0E | INT1E | INT0E | EMI |
| R/W  | — | R/W  | R/W   | R/W   | R/W  | R/W   | R/W   | R/W |
| POR  | — | 0    | 0     | 0     | 0    | 0     | 0     | 0   |

Bit 7 Unimplemented, read as "0"

Bit 6 **CP0F**: Comparator 0 interrupt request flag

- 0: No Request
- 1: Interrupt Request

Bit 5 **INT1F**: INT1 interrupt request flag

- 0: No Request
- 1: Interrupt Request

Bit 4 **INT0F**: INT0 interrupt request flag

- 0: No Request
- 1: Interrupt Request

Bit 3 **CP0E**: Comparator 0 interrupt control

- 0: Disable
- 1: Enable

Bit 2 **INT1E**: INT1 interrupt control

- 0: Disable
- 1: Enable

Bit 1 **INT0E**: INT0 interrupt control

- 0: Disable
- 1: Enable

Bit 0 **EMI**: Global interrupt control

- 0: Disable
- 1: Enable

• **INTC1 Register**

| Bit  | 7   | 6    | 5    | 4    | 3   | 2    | 1    | 0    |
|------|-----|------|------|------|-----|------|------|------|
| Name | ADF | MF1F | MF0F | CP1F | ADE | MF1E | MF0E | CP1E |
| R/W  | R/W | R/W  | R/W  | R/W  | R/W | R/W  | R/W  | R/W  |
| POR  | 0   | 0    | 0    | 0    | 0   | 0    | 0    | 0    |

Bit 7      **ADF**: A/D Converter interrupt request flag

0: No Request  
1: Interrupt Request

Bit 6      **MF1F**: Multi-function 1 interrupt request flag

0: No Request  
1: Interrupt Request

Bit 5      **MF0F**: Multi-function 0 interrupt request flag

0: No Request  
1: Interrupt Request

Bit 4      **CP1F**: Comparator 1 interrupt request flag

0: No Request  
1: Interrupt Request

Bit 3      **ADE**: A/D Converter interrupt control

0: Disable  
1: Enable

Bit 2      **MF1E**: Multi-function 1 interrupt control

0: Disable  
1: Enable

Bit 1      **MF0E**: Multi-function 0 interrupt control

0: Disable  
1: Enable

Bit 0      **CP1E**: Comparator 1 interrupt control

0: Disable  
1: Enable

• **INTC2 Register**

| Bit  | 7    | 6    | 5    | 4    | 3    | 2    | 1    | 0    |
|------|------|------|------|------|------|------|------|------|
| Name | MF3F | TB1F | TB0F | MF2F | MF3E | TB1E | TB0E | MF2E |
| R/W  | R/W  | R/W  | R/W  | R/W  | R/W  | R/W  | R/W  | R/W  |
| POR  | 0    | 0    | 0    | 0    | 0    | 0    | 0    | 0    |

- Bit 7      **MF3F**: Multi-function 3 interrupt request flag  
             0: No Request  
             1: Interrupt Request
  
- Bit 6      **TB1F**: Time Base 1 interrupt request flag  
             0: No Request  
             1: Interrupt Request
  
- Bit 5      **TB0F**: Time Base 0 interrupt request flag  
             0: No Request  
             1: Interrupt Request
  
- Bit 4      **MF2F**: Multi-function 2 interrupt request flag  
             0: No Request  
             1: Interrupt Request
  
- Bit 3      **MF3E**: Multi-function 3 interrupt control  
             0: Disable  
             1: Enable
  
- Bit 2      **TB1E**: Time Base 1 interrupt control  
             0: Disable  
             1: Enable
  
- Bit 1      **TB0E**: Time Base 0 interrupt control  
             0: Disable  
             1: Enable
  
- Bit 0      **MF2E**: Multi-function 2 interrupt control  
             0: Disable  
             1: Enable

• **INTC3 Register**

| Bit  | 7    | 6    | 5     | 4     | 3    | 2    | 1     | 0     |
|------|------|------|-------|-------|------|------|-------|-------|
| Name | MF5F | MF4F | INT3F | INT2F | MF5E | MF4E | INT3E | INT2E |
| R/W  | R/W  | R/W  | R/W   | R/W   | R/W  | R/W  | R/W   | R/W   |
| POR  | 0    | 0    | 0     | 0     | 0    | 0    | 0     | 0     |

- Bit 7      **MF5F**: Multi-function 5 interrupt request flag  
             0: No Request  
             1: Interrupt Request
- Bit 6      **MF4F**: Multi-function 4 interrupt request flag  
             0: No Request  
             1: Interrupt Request
- Bit 5      **INT3F**: INT3 interrupt request flag  
             0: No Request  
             1: Interrupt Request
- Bit 4      **INT2F**: INT2 interrupt request flag  
             0: No Request  
             1: Interrupt Request
- Bit 3      **MF5E**: Multi-function 5 interrupt control  
             0: Disable  
             1: Enable
- Bit 2      **MF4E**: Multi-function 4 interrupt control  
             0: Disable  
             1: Enable
- Bit 1      **INT3E**: INT3 interrupt control  
             0: Disable  
             1: Enable
- Bit 0      **INT2E**: INT2 interrupt control  
             0: Disable  
             1: Enable

• **MFI0 Register**

| Bit  | 7      | 6      | 5      | 4      | 3      | 2      | 1      | 0      |
|------|--------|--------|--------|--------|--------|--------|--------|--------|
| Name | STM0AF | STM0PF | PTM0AF | PTM0PF | STM0AE | STM0PE | PTM0AE | PTM0PE |
| R/W  | R/W    | R/W    | R/W    | R/W    | R/W    | R/W    | R/W    | R/W    |
| POR  | 0      | 0      | 0      | 0      | 0      | 0      | 0      | 0      |

- Bit 7      **STM0AF**: STM0 Comparator A match Interrupt request flag  
             0: No Request  
             1: Interrupt Request
- Bit 6      **STM0PF**: STM0 Comparator P match Interrupt request flag  
             0: No Request  
             1: Interrupt Request
- Bit 5      **PTM0AF**: PTM0 Comparator A match Interrupt request flag  
             0: No Request  
             1: Interrupt Request
- Bit 4      **PTM0PF**: PTM0 Comparator P match Interrupt request flag  
             0: No Request  
             1: Interrupt Request
- Bit 3      **STM0AE**: STM0 Comparator A match Interrupt control  
             0: Disable  
             1: Enable
- Bit 2      **STM0PE**: STM0 Comparator P match Interrupt control  
             0: Disable  
             1: Enable
- Bit 1      **PTM0AE**: PTM0 Comparator A match Interrupt control  
             0: Disable  
             1: Enable
- Bit 0      **PTM0PE**: PTM0 Comparator P match Interrupt control  
             0: Disable  
             1: Enable

• **MF1 Register**

| Bit  | 7      | 6      | 5      | 4      | 3      | 2      | 1      | 0      |
|------|--------|--------|--------|--------|--------|--------|--------|--------|
| Name | STM1AF | STM1PF | PTM1AF | PTM1PF | STM1AE | STM1PE | PTM1AE | PTM1PE |
| R/W  | R/W    | R/W    | R/W    | R/W    | R/W    | R/W    | R/W    | R/W    |
| POR  | 0      | 0      | 0      | 0      | 0      | 0      | 0      | 0      |

- Bit 7      **STM1AF**: STM1 Comparator A match Interrupt request flag  
             0: No Request  
             1: Interrupt Request
- Bit 6      **STM1PF**: STM1 Comparator P match Interrupt request flag  
             0: No Request  
             1: Interrupt Request
- Bit 5      **PTM1AF**: PTM1 Comparator A match Interrupt request flag  
             0: No Request  
             1: Interrupt Request
- Bit 4      **PTM1PF**: PTM1 Comparator P match Interrupt request flag  
             0: No Request  
             1: Interrupt Request
- Bit 3      **STM1AE**: STM1 Comparator A match Interrupt control  
             0: Disable  
             1: Enable
- Bit 2      **STM1PE**: STM1 Comparator P match Interrupt control  
             0: Disable  
             1: Enable
- Bit 1      **PTM1AE**: PTM1 Comparator A match Interrupt control  
             0: Disable  
             1: Enable
- Bit 0      **PTM1PE**: PTM1 Comparator P match Interrupt control  
             0: Disable  
             1: Enable

• **MF12 Register**

| Bit  | 7 | 6 | 5      | 4      | 3 | 2 | 1      | 0      |
|------|---|---|--------|--------|---|---|--------|--------|
| Name | — | — | PTM2AF | PTM2PF | — | — | PTM2AE | PTM2PE |
| R/W  | — | — | R/W    | R/W    | — | — | R/W    | R/W    |
| POR  | — | — | 0      | 0      | — | — | 0      | 0      |

- Bit 7~6    Unimplemented, read as "0"
- Bit 5      **PTM2AF**: PTM2 Comparator A match Interrupt request flag  
             0: No Request  
             1: Interrupt Request
- Bit 4      **PTM2PF**: PTM2 Comparator P match Interrupt request flag  
             0: No Request  
             1: Interrupt Request
- Bit 3~2    Unimplemented, read as "0"
- Bit 1      **PTM2AE**: PTM2 Comparator A match Interrupt control  
             0: Disable  
             1: Enable
- Bit 0      **PTM2PE**: PTM2 Comparator P match Interrupt control  
             0: Disable  
             1: Enable

• **MFI3 Register**

| Bit  | 7    | 6     | 5   | 4   | 3    | 2     | 1   | 0   |
|------|------|-------|-----|-----|------|-------|-----|-----|
| Name | SIMF | SPIAF | DEF | LVF | SIME | SPIAE | DEE | LVE |
| R/W  | R/W  | R/W   | R/W | R/W | R/W  | R/W   | R/W | R/W |
| POR  | 0    | 0     | 0   | 0   | 0    | 0     | 0   | 0   |

- Bit 7      **SIMF**: SIM Interrupt request flag  
             0: No Request  
             1: Interrupt Request
  
- Bit 6      **SPIAF**: SPIA Interrupt request flag  
             0: No Request  
             1: Interrupt Request
  
- Bit 5      **DEF**: Data EEPROM Interrupt request flag  
             0: No Request  
             1: Interrupt Request
  
- Bit 4      **LVF**: LVD Interrupt request flag  
             0: No Request  
             1: Interrupt Request
  
- Bit 3      **SIME**: SIM Interrupt control  
             0: Disable  
             1: Enable
  
- Bit 2      **SPIAE**: SPIA Interrupt control  
             0: Disable  
             1: Enable
  
- Bit 1      **DEE**: Data EEPROM Interrupt control  
             0: Disable  
             1: Enable
  
- Bit 0      **LVE**: LVD Interrupt control  
             0: Disable  
             1: Enable

• **MFI4 Register**

| Bit  | 7      | 6      | 5      | 4      | 3      | 2      | 1      | 0      |
|------|--------|--------|--------|--------|--------|--------|--------|--------|
| Name | STM2AF | STM2PF | PTM3AF | PTM3PF | STM2AE | STM2PE | PTM3AE | PTM3PE |
| R/W  | R/W    | R/W    | R/W    | R/W    | R/W    | R/W    | R/W    | R/W    |
| POR  | 0      | 0      | 0      | 0      | 0      | 0      | 0      | 0      |

- Bit 7      **STM2AF**: STM2 Comparator A match Interrupt request flag  
             0: No Request  
             1: Interrupt Request
- Bit 6      **STM2PF**: STM2 Comparator P match Interrupt request flag  
             0: No Request  
             1: Interrupt Request
- Bit 5      **PTM3AF**: PTM3 Comparator A match Interrupt request flag  
             0: No Request  
             1: Interrupt Request
- Bit 4      **PTM3PF**: PTM3 Comparator P match Interrupt request flag  
             0: No Request  
             1: Interrupt Request
- Bit 3      **STM2AE**: STM2 Comparator A match Interrupt control  
             0: Disable  
             1: Enable
- Bit 2      **STM2PE**: STM2 Comparator P match Interrupt control  
             0: Disable  
             1: Enable
- Bit 1      **PTM3AE**: PTM3 Comparator A match Interrupt control  
             0: Disable  
             1: Enable
- Bit 0      **PTM3PE**: PTM3 Comparator P match Interrupt control  
             0: Disable  
             1: Enable

• **MFI5 Register – HT66F2350/HT66F2360**

| Bit  | 7 | 6 | 5    | 4    | 3 | 2 | 1    | 0    |
|------|---|---|------|------|---|---|------|------|
| Name | — | — | UR1F | UR0F | — | — | UR1E | UR0E |
| R/W  | — | — | R/W  | R/W  | — | — | R/W  | R/W  |
| POR  | — | — | 0    | 0    | — | — | 0    | 0    |

- Bit 7~6 Unimplemented, read as "0"
- Bit 5 **UR1F**: UART1 transfer interrupt request flag  
0: No Request  
1: Interrupt Request
- Bit 4 **UR0F**: UART0 transfer interrupt request flag  
0: No Request  
1: Interrupt Request
- Bit 3~2 Unimplemented, read as "0"
- Bit 1 **UR1E**: UART1 transfer interrupt control  
0: Disable  
1: Enable
- Bit 0 **UR0E**: UART0 transfer interrupt control  
0: Disable  
1: Enable

• **MFI5 Register – HT66F2370/HT66F2390**

| Bit  | 7 | 6    | 5    | 4    | 3 | 2    | 1    | 0    |
|------|---|------|------|------|---|------|------|------|
| Name | — | UR2F | UR1F | UR0F | — | UR2E | UR1E | UR0E |
| R/W  | — | R/W  | R/W  | R/W  | — | R/W  | R/W  | R/W  |
| POR  | — | 0    | 0    | 0    | — | 0    | 0    | 0    |

- Bit 7 Unimplemented, read as "0"
- Bit 6 **UR2F**: UART2 transfer interrupt request flag  
0: no request  
1: interrupt request
- Bit 5 **UR1F**: UART1 transfer interrupt request flag  
0: No Request  
1: Interrupt Request
- Bit 4 **UR0F**: UART0 transfer interrupt request flag  
0: No Request  
1: Interrupt Request
- Bit 3 Unimplemented, read as "0"
- Bit 2 **UR2E**: UART2 transfer interrupt control  
0: Disable  
1: Enable
- Bit 1 **UR1E**: UART1 transfer interrupt control  
0: Disable  
1: Enable
- Bit 0 **UR0E**: UART0 transfer interrupt control  
0: Disable  
1: Enable

## Interrupt Operation

When the conditions for an interrupt event occur, such as a TM Comparator P or Comparator A or A/D conversion completion, etc, the relevant interrupt request flag will be set. Whether the request flag actually generates a program jump to the relevant interrupt vector is determined by the condition of the interrupt enable bit. If the enable bit is set high then the program will jump to its relevant vector; if the enable bit is zero then although the interrupt request flag is set an actual interrupt will not be generated and the program will not jump to the relevant interrupt vector. The global interrupt enable bit, if cleared to zero, will disable all interrupts.

When an interrupt is generated, the Program Counter, which stores the address of the next instruction to be executed, will be transferred onto the stack. The Program Counter will then be loaded with a new address which will be the value of the corresponding interrupt vector. The microcontroller will then fetch its next instruction from this interrupt vector. The instruction at this vector will usually be a JMP which will jump to another section of program which is known as the interrupt service routine. Here is located the code to control the appropriate interrupt. The interrupt service routine must be terminated with a RETI, which retrieves the original Program Counter address from the stack and allows the microcontroller to continue with normal execution at the point where the interrupt occurred.

The various interrupt enable bits, together with their associated request flags, are shown in the accompanying diagrams with their order of priority. Some interrupt sources have their own individual vector while others share the same multi-function interrupt vector. Once an interrupt subroutine is serviced, all other interrupts will be blocked, as the global interrupt enable bit, EMI bit will be cleared automatically. This will prevent any further interrupt nesting from occurring. However, if other interrupt requests occur during this interval, although the interrupt will not be immediately serviced, the request flag will still be recorded.

If an interrupt requires immediate servicing while the program is already in another interrupt service routine, the EMI bit should be set after entering the routine to allow interrupt nesting. If the stack is full, the interrupt request will not be acknowledged, even if the related interrupt is enabled, until the Stack Pointer is decremented. If immediate service is desired, the stack must be prevented from becoming full. In case of simultaneous requests, the accompanying diagram shows the priority that is applied. All of the interrupt request flags when set will wake-up the device if it is in SLEEP or IDLE Mode, however to prevent a wake-up from occurring the corresponding flag should be set before the device is in SLEEP or IDLE Mode.

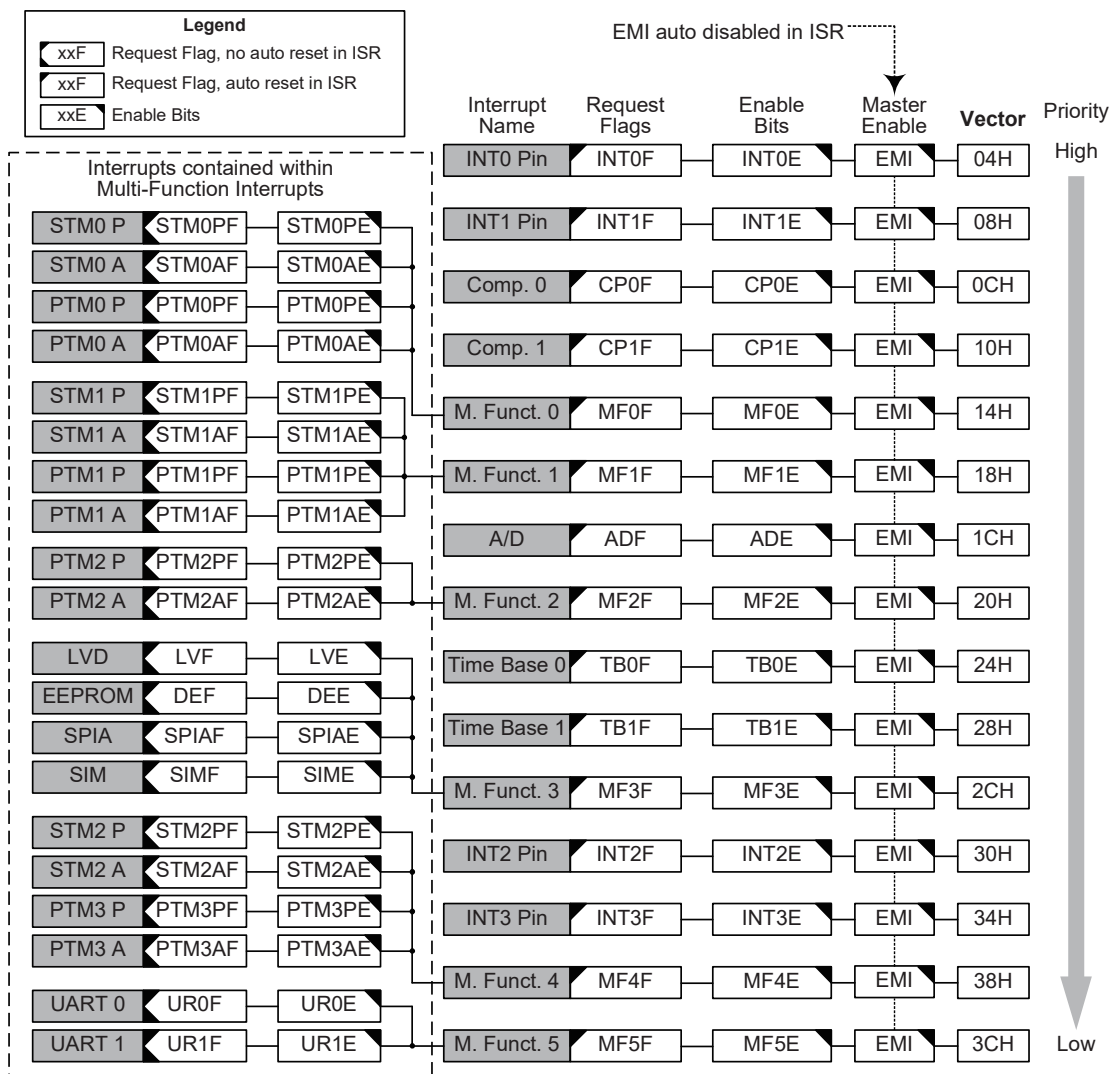

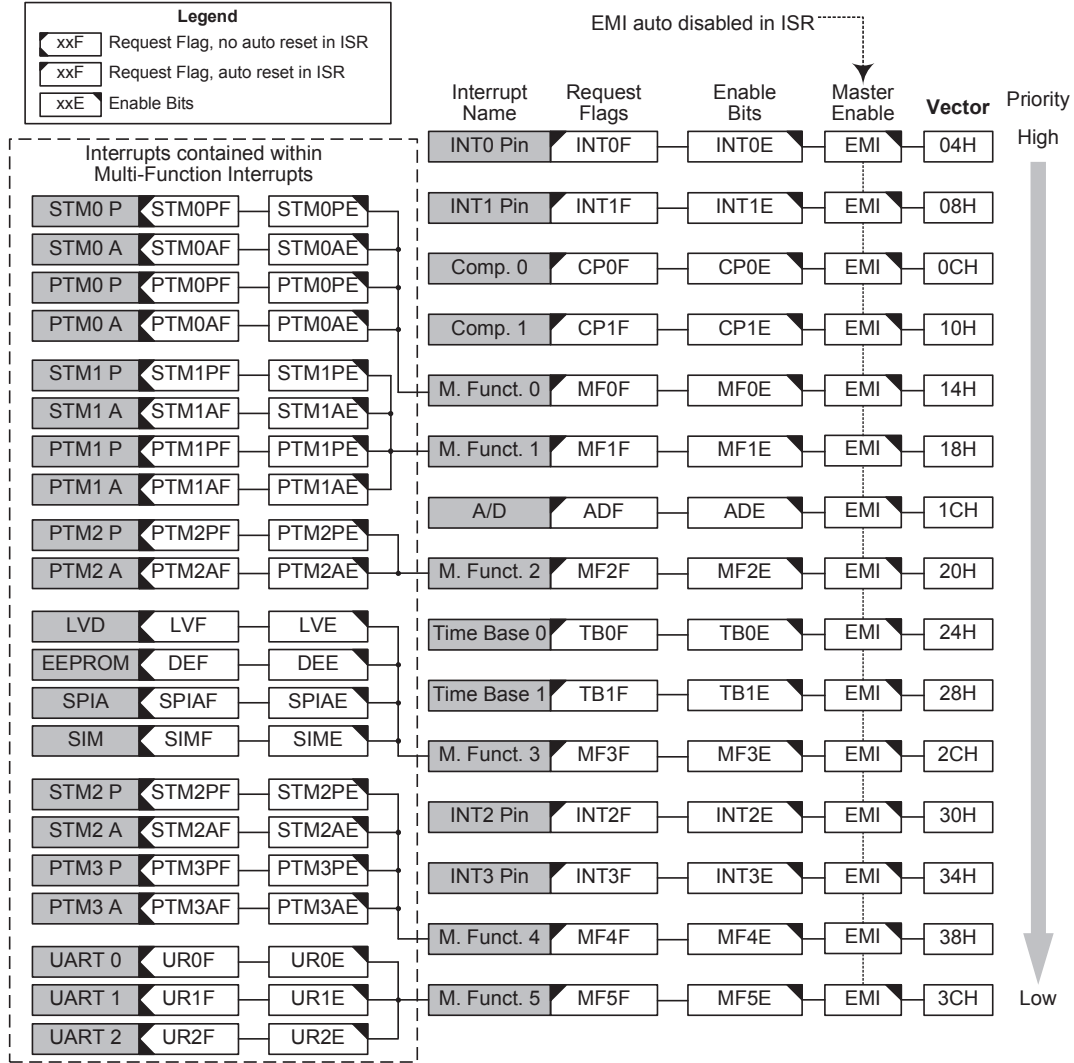

Interrupt Scheme – HT66F2370/HT66F2390

## External Interrupt

The external interrupts are controlled by signal transitions on the pins INT0~INT3. An external interrupt request will take place when the external interrupt request flags, INT0F~INT3F, are set, which will occur when a transition, whose type is chosen by the edge select bits, appears on the external interrupt pins. To allow the program to branch to its respective interrupt vector address, the global interrupt enable bit, EMI, and respective external interrupt enable bit, INT0E~INT3E, must first be set. Additionally the correct interrupt edge type must be selected using the INTEG register to enable the external interrupt function and to choose the trigger edge type. As the external interrupt pins are pin-shared with I/O pins, they can only be configured as external interrupt pins if their external interrupt enable bit in the corresponding interrupt register has been set and the external interrupt pin is selected by the corresponding pin-shared function selection bits. The pin must also be setup as an input by setting the corresponding bit in the port control register. When the interrupt is enabled, the stack is not full and the correct transition type appears on the external interrupt pin, a subroutine call to the external interrupt vector, will take place. When the interrupt is serviced, the external interrupt request flags, INT0F~INT3F, will be automatically reset and the EMI bit will be automatically cleared to disable other interrupts. Note that any pull-high resistor selections on the external interrupt pins will remain valid even if the pin is used as an external interrupt input.

The INTEG register is used to select the type of active edge that will trigger the external interrupt. A choice of either rising or falling or both edge types can be chosen to trigger an external interrupt. Note that the INTEG register can also be used to disable the external interrupt function.

## Comparator Interrupt

The comparator interrupt is controlled by the two internal comparators. A comparator interrupt request will take place when the comparator interrupt request flags, CP0F or CP1F, are set, a situation that will occur when the comparator output bit changes state. To allow the program to branch to its respective interrupt vector address, the global interrupt enable bit, EMI, and comparator interrupt enable bit, CP0E or CP1E, must first be set. When the interrupt is enabled, the stack is not full and the comparator inputs generate a comparator output transition, a subroutine call to the comparator interrupt vector, will take place. When the interrupt is serviced, the comparator interrupt request flag will be automatically reset and the EMI bit will also be automatically cleared to disable other interrupts.

## Multi-function Interrupt

Within the device there are up to five Multi-function interrupts. Unlike the other independent interrupts, these interrupts have no independent source, but rather are formed from other existing interrupt sources, namely the TM interrupts, LVD interrupt, EEPROM write operation interrupt, SIM interface, SPIA interface and UART interface interrupts.

A Multi-function interrupt request will take place when any of the Multi-function interrupt request flags MFnF are set. The Multi-function interrupt flags will be set when any of their included functions generate an interrupt request flag. To allow the program to branch to its respective interrupt vector address, when the Multi-function interrupt is enabled and the stack is not full, and either one of the interrupts contained within each of Multi-function interrupt occurs, a subroutine call to one of the Multi-function interrupt vectors will take place. When the interrupt is serviced, the related Multi-Function request flag will be automatically reset and the EMI bit will be automatically cleared to disable other interrupts.

However, it must be noted that, although the Multi-function Interrupt request flags will be automatically reset when the interrupt is serviced, the request flags from the original source of the Multi-function interrupts will not be automatically reset and must be manually reset by the application program.

### A/D Converter Interrupt

The A/D Converter Interrupt is controlled by the termination of an A/D conversion process. An A/D Converter Interrupt request will take place when the A/D Converter Interrupt request flag, ADF, is set, which occurs when the A/D conversion process finishes. To allow the program to branch to its respective interrupt vector address, the global interrupt enable bit, EMI, and A/D Interrupt enable bit, ADE, must first be set. When the interrupt is enabled, the stack is not full and the A/D conversion process has ended, a subroutine call to the A/D Converter Interrupt vector, will take place. When the interrupt is serviced, the A/D Converter Interrupt flag, ADF, will be automatically cleared. The EMI bit will also be automatically cleared to disable other interrupts.

### Time Base Interrupt

The function of the Time Base Interrupt is to provide regular time signal in the form of an internal interrupt. It is controlled by the overflow signal from its internal timer. When this happens its interrupt request flag, TBnF, will be set. To allow the program to branch to its respective interrupt vector addresses, the global interrupt enable bit, EMI and Time Base enable bit, TBnE, must first be set. When the interrupt is enabled, the stack is not full and the Time Base overflows, a subroutine call to its respective vector location will take place. When the interrupt is serviced, the interrupt request flag, TBnF, will be automatically reset and the EMI bit will be cleared to disable other interrupts.

The purpose of the Time Base Interrupt is to provide an interrupt signal at fixed time periods. Its clock source,  $f_{PSC0}$  or  $f_{PSC1}$ , originates from the internal clock source  $f_{SYS}$ ,  $f_{SYS}/4$  or  $f_{SUB}$  and then passes through a divider, the division ratio of which is selected by programming the appropriate bits in the TB0C and TB1C registers to obtain longer interrupt periods whose value ranges. The clock source which in turn controls the Time Base interrupt period is selected using the CLKSEL0[1:0] and CLKSEL1[1:0] bits in the PSC0R and PSC1R register respectively.

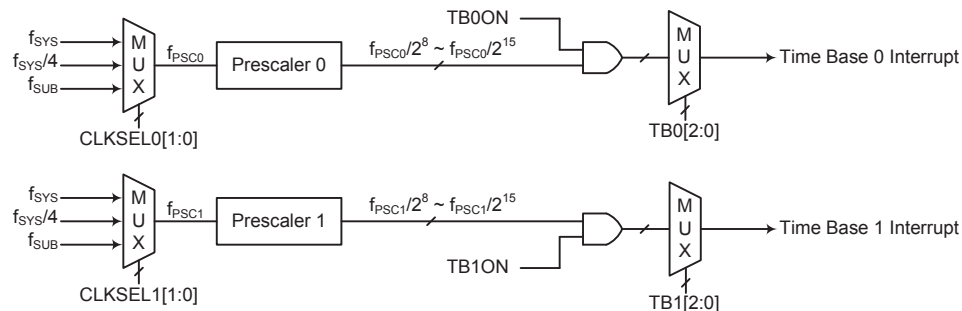

**Time Base Interrupts**

#### • PSC0R Register

| Bit  | 7 | 6 | 5 | 4 | 3 | 2 | 1        | 0        |
|------|---|---|---|---|---|---|----------|----------|
| Name | — | — | — | — | — | — | CLKSEL01 | CLKSEL00 |
| R/W  | — | — | — | — | — | — | R/W      | R/W      |
| POR  | — | — | — | — | — | — | 0        | 0        |

Bit 7~2 Unimplemented, read as "0"

Bit 1~0 **CLKSEL01~CLKSEL00**: Prescaler 0 clock source  $f_{PSC0}$  selection  
 00:  $f_{SYS}$   
 01:  $f_{SYS}/4$   
 1x:  $f_{SUB}$

• **PSC1R Register**

| Bit  | 7 | 6 | 5 | 4 | 3 | 2 | 1        | 0        |
|------|---|---|---|---|---|---|----------|----------|
| Name | — | — | — | — | — | — | CLKSEL11 | CLKSEL10 |
| R/W  | — | — | — | — | — | — | R/W      | R/W      |
| POR  | — | — | — | — | — | — | 0        | 0        |

Bit 7~2 Unimplemented, read as "0"

Bit 1~0 **CLKSEL11~CLKSEL10**: Prescaler 1 clock source  $f_{PSC1}$  selection

00:  $f_{SYS}$

01:  $f_{SYS}/4$

1x:  $f_{SUB}$

• **TB0C Register**

| Bit  | 7     | 6 | 5 | 4 | 3 | 2    | 1    | 0    |
|------|-------|---|---|---|---|------|------|------|
| Name | TB0ON | — | — | — | — | TB02 | TB01 | TB00 |
| R/W  | R/W   | — | — | — | — | R/W  | R/W  | R/W  |
| POR  | 0     | — | — | — | — | 0    | 0    | 0    |

Bit 7 **TB0ON**: Time Base 0 Enable Control

0: Disable

1: Enable

Bit 6~3 Unimplemented, read as "0"

Bit 2~0 **TB02~TB00**: Time Base 0 time-out period selection

000:  $2^8/f_{PSC0}$

001:  $2^9/f_{PSC0}$

010:  $2^{10}/f_{PSC0}$

011:  $2^{11}/f_{PSC0}$

100:  $2^{12}/f_{PSC0}$

101:  $2^{13}/f_{PSC0}$

110:  $2^{14}/f_{PSC0}$

111:  $2^{15}/f_{PSC0}$

• **TB1C Register**

| Bit  | 7     | 6 | 5 | 4 | 3 | 2    | 1    | 0    |
|------|-------|---|---|---|---|------|------|------|
| Name | TB1ON | — | — | — | — | TB12 | TB11 | TB10 |
| R/W  | R/W   | — | — | — | — | R/W  | R/W  | R/W  |
| POR  | 0     | — | — | — | — | 0    | 0    | 0    |

Bit 7 **TB1ON**: Time Base 1 Enable Control

0: Disable

1: Enable

Bit 6~3 Unimplemented, read as "0"

Bit 2~0 **TB12~TB10**: Time Base 1 time-out period selection

000:  $2^8/f_{PSC1}$

001:  $2^9/f_{PSC1}$

010:  $2^{10}/f_{PSC1}$

011:  $2^{11}/f_{PSC1}$

100:  $2^{12}/f_{PSC1}$

101:  $2^{13}/f_{PSC1}$

110:  $2^{14}/f_{PSC1}$

111:  $2^{15}/f_{PSC1}$

### TM Interrupt

The Standard and Periodic TMs have two interrupts, one comes from the comparator A match situation and the other comes from the comparator P match situation. All of the TM interrupts are contained within the Multi-function Interrupts. For all of the TM types there are two interrupt request flags and two enable control bits. A TM interrupt request will take place when any of the TM request flags are set, a situation which occurs when a TM comparator P or A match situation happens.

To allow the program to branch to its respective interrupt vector address, the global interrupt enable bit, EMI, respective TM Interrupt enable bit, and relevant Multi-function Interrupt enable bit, MFnE, must first be set. When the interrupt is enabled, the stack is not full and a TM comparator match situation occurs, a subroutine call to the relevant Multi-function Interrupt vector locations, will take place. When the TM interrupt is serviced, the EMI bit will be automatically cleared to disable other interrupts. However, only the related MFnF flag will be automatically cleared. As the TM interrupt request flags will not be automatically cleared, they have to be cleared by the application program.

### LVD Interrupt

The Low Voltage Detector Interrupt is contained within the Multi-function Interrupt. An LVD Interrupt request will take place when the LVD Interrupt request flag, LVF, is set, which occurs when the Low Voltage Detector function detects a low power supply voltage. To allow the program to branch to its respective interrupt vector address, the global interrupt enable bit, EMI, Low Voltage Interrupt enable bit, LVE, and associated Multi-function interrupt enable bit, must first be set. When the interrupt is enabled, the stack is not full and a low voltage condition occurs, a subroutine call to the Multi-function Interrupt vector, will take place. When the Low Voltage Interrupt is serviced, the EMI bit will be automatically cleared to disable other interrupts. However, only the Multi-function interrupt request flag will be also automatically cleared. As the LVF flag will not be automatically cleared, it has to be cleared by the application program.

### EEPROM Interrupt

The EEPROM Write Interrupt is contained within the Multi-function Interrupt. An EEPROM Write Interrupt request will take place when the EEPROM Write Interrupt request flag, DEF, is set, which occurs when an EEPROM Write cycle ends. To allow the program to branch to its respective interrupt vector address, the global interrupt enable bit, EMI, EEPROM Write Interrupt enable bit, DEE, and associated Multi-function interrupt enable bit must first be set. When the interrupt is enabled, the stack is not full and an EEPROM Write cycle ends, a subroutine call to the respective Multi-function Interrupt vector will take place. When the EEPROM Write Interrupt is serviced, the EMI bit will be automatically cleared to disable other interrupts. However, only the Multi-function interrupt request flag will be automatically cleared. As the DEF flag will not be automatically cleared, it has to be cleared by the application program.

## **Serial Interface Module Interrupt**

The Serial Interface Module Interrupt, also known as the SIM interrupt, is contained within the Multi-function Interrupt. A SIM Interrupt request will take place when the SIM Interrupt request flag, SIMF, is set, which occurs when a byte of data has been received or transmitted by the SIM interface, an I<sup>2</sup>C slave address match or I<sup>2</sup>C bus time-out occurrence. To allow the program to branch to its respective interrupt vector address, the global interrupt enable bit, EMI, the Serial Interface Interrupt enable bit, SIME, and Multi-function interrupt enable bit must first be set. When the interrupt is enabled, the stack is not full and any of the above described situations occurs, a subroutine call to the respective Multi-function Interrupt vector, will take place. When the Serial Interface Interrupt is serviced, the EMI bit will be automatically cleared to disable other interrupts, however only the Multi-function interrupt request flag will be also automatically cleared. As the SIMF flag will not be automatically cleared, it has to be cleared by the application program.

## **SPIA Interface Interrupt**

The SPIA Interface Module Interrupt is contained within the Multi-function Interrupt. A SPIA Interrupt request will take place when the SPIA Interrupt request flag, SPIAF, is set, which occurs when a byte of data has been received or transmitted by the SPIA interface. To allow the program to branch to its respective interrupt vector address, the global interrupt enable bit, EMI, the Serial Interface Interrupt enable bit, SPIAE, and Multi-function interrupt enable bit must first be set. When the interrupt is enabled, the stack is not full and a byte of data has been transmitted or received by the SPIA interface, a subroutine call to the respective Multi-function Interrupt vector, will take place. When the SPIA Interface Interrupt is serviced, the EMI bit will be automatically cleared to disable other interrupts. However, only the Multi-function interrupt request flag will be also automatically cleared. As the SPIAF flag will not be automatically cleared, it has to be cleared by the application program.

## **UART Transfer Interrupt**

The UART Transfer Interrupt is controlled by several UART<sub>n</sub> transfer conditions. When one of these conditions occurs, an interrupt pulse will be generated to get the attention of the microcontroller. These conditions are a transmitter data register empty, transmitter idle, receiver data available, receiver overrun, address detect and an RX<sub>n</sub> pin wake-up. To allow the program to branch to its respective interrupt vector address, the global interrupt enable bit, EMI, and UART Interrupt enable bit, UR<sub>n</sub>E, must first be set. When the interrupt is enabled, the stack is not full and any of the conditions described above occurs, a subroutine call to the UART<sub>n</sub> Interrupt vector, will take place. When the interrupt is serviced, the UART<sub>n</sub> Interrupt flag, UR<sub>n</sub>F, will be automatically cleared. The EMI bit will also be automatically cleared to disable other interrupts.

## **Interrupt Wake-up Function**

Each of the interrupt functions has the capability of waking up the microcontroller when in the SLEEP or IDLE Mode. A wake-up is generated when an interrupt request flag changes from low to high and is independent of whether the interrupt is enabled or not. Therefore, even though these devices are in the SLEEP or IDLE Mode and its system oscillator stopped, situations such as external edge transitions on the external interrupt pins, a low power supply voltage or comparator input change may cause their respective interrupt flag to be set high and consequently generate an interrupt. Care must therefore be taken if spurious wake-up situations are to be avoided. If an interrupt wake-up function is to be disabled then the corresponding interrupt request flag should be set high before the device enters the SLEEP or IDLE Mode. The interrupt enable bits have no effect on the interrupt wake-up function.

## Programming Considerations

By disabling the relevant interrupt enable bits, a requested interrupt can be prevented from being serviced, however, once an interrupt request flag is set, it will remain in this condition in the interrupt register until the corresponding interrupt is serviced or until the request flag is cleared by the application program.

Where a certain interrupt is contained within a Multi-function interrupt, then when the interrupt service routine is executed, as only the Multi-function interrupt request flags, MFnF, will be automatically cleared, the individual request flag for the function needs to be cleared by the application program.

It is recommended that programs do not use the "CALL" instruction within the interrupt service subroutine. Interrupts often occur in an unpredictable manner or need to be serviced immediately. If only one stack is left and the interrupt is not well controlled, the original control sequence will be damaged once a CALL subroutine is executed in the interrupt subroutine.

Every interrupt has the capability of waking up the microcontroller when it is in the SLEEP or IDLE Mode, the wake up being generated when the interrupt request flag changes from low to high. If it is required to prevent a certain interrupt from waking up the microcontroller then its respective request flag should be first set high before enter SLEEP or IDLE Mode.

As only the Program Counter is pushed onto the stack, then when the interrupt is serviced, if the contents of the accumulator, status register or other registers are altered by the interrupt service program, their contents should be saved to the memory at the beginning of the interrupt service routine.

To return from an interrupt subroutine, either a RET or RETI instruction may be executed. The RETI instruction in addition to executing a return to the main program also automatically sets the EMI bit high to allow further interrupts. The RET instruction however only executes a return to the main program leaving the EMI bit in its present zero state and therefore disabling the execution of further interrupts.

## Application Circuits

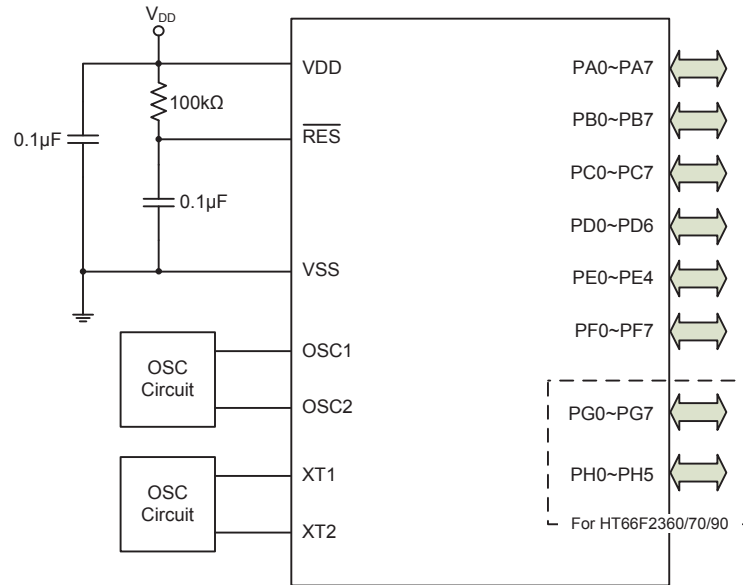

## Instruction Set

### Introduction

Central to the successful operation of any microcontroller is its instruction set, which is a set of program instruction codes that directs the microcontroller to perform certain operations. In the case of Holtek microcontroller, a comprehensive and flexible set of over 60 instructions is provided to enable programmers to implement their application with the minimum of programming overheads.

For easier understanding of the various instruction codes, they have been subdivided into several functional groupings.

### Instruction Timing

Most instructions are implemented within one instruction cycle. The exceptions to this are branch, call, or table read instructions where two instruction cycles are required. One instruction cycle is equal to 4 system clock cycles, therefore in the case of an 8MHz system oscillator, most instructions would be implemented within 0.5 $\mu$ s and branch or call instructions would be implemented within 1 $\mu$ s. Although instructions which require one more cycle to implement are generally limited to the JMP, CALL, RET, RETI and table read instructions, it is important to realize that any other instructions which involve manipulation of the Program Counter Low register or PCL will also take one more cycle to implement. As instructions which change the contents of the PCL will imply a direct jump to that new address, one more cycle will be required. Examples of such instructions would be "CLR PCL" or "MOV PCL, A". For the case of skip instructions, it must be noted that if the result of the comparison involves a skip operation then this will also take one more cycle, if no skip is involved then only one cycle is required.

### Moving and Transferring Data

The transfer of data within the microcontroller program is one of the most frequently used operations. Making use of three kinds of MOV instructions, data can be transferred from registers to the Accumulator and vice-versa as well as being able to move specific immediate data directly into the Accumulator. One of the most important data transfer applications is to receive data from the input ports and transfer data to the output ports.

### Arithmetic Operations

The ability to perform certain arithmetic operations and data manipulation is a necessary feature of most microcontroller applications. Within the Holtek microcontroller instruction set are a range of add and subtract instruction mnemonics to enable the necessary arithmetic to be carried out. Care must be taken to ensure correct handling of carry and borrow data when results exceed 255 for addition and less than 0 for subtraction. The increment and decrement instructions INC, INCA, DEC and DECA provide a simple means of increasing or decreasing by a value of one of the values in the destination specified.

## Logical and Rotate Operation

The standard logical operations such as AND, OR, XOR and CPL all have their own instruction within the Holtek microcontroller instruction set. As with the case of most instructions involving data manipulation, data must pass through the Accumulator which may involve additional programming steps. In all logical data operations, the zero flag may be set if the result of the operation is zero. Another form of logical data manipulation comes from the rotate instructions such as RR, RL, RRC and RLC which provide a simple means of rotating one bit right or left. Different rotate instructions exist depending on program requirements. Rotate instructions are useful for serial port programming applications where data can be rotated from an internal register into the Carry bit from where it can be examined and the necessary serial bit set high or low. Another application which rotate data operations are used is to implement multiplication and division calculations.

## Branches and Control Transfer

Program branching takes the form of either jumps to specified locations using the JMP instruction or to a subroutine using the CALL instruction. They differ in the sense that in the case of a subroutine call, the program must return to the instruction immediately when the subroutine has been carried out. This is done by placing a return instruction "RET" in the subroutine which will cause the program to jump back to the address right after the CALL instruction. In the case of a JMP instruction, the program simply jumps to the desired location. There is no requirement to jump back to the original jumping off point as in the case of the CALL instruction. One special and extremely useful set of branch instructions are the conditional branches. Here a decision is first made regarding the condition of a certain data memory or individual bits. Depending upon the conditions, the program will continue with the next instruction or skip over it and jump to the following instruction. These instructions are the key to decision making and branching within the program perhaps determined by the condition of certain input switches or by the condition of internal data bits.

## Bit Operations

The ability to provide single bit operations on Data Memory is an extremely flexible feature of all Holtek microcontrollers. This feature is especially useful for output port bit programming where individual bits or port pins can be directly set high or low using either the "SET [m].i" or "CLR [m].i" instructions respectively. The feature removes the need for programmers to first read the 8-bit output port, manipulate the input data to ensure that other bits are not changed and then output the port with the correct new data. This read-modify-write process is taken care of automatically when these bit operation instructions are used.

## Table Read Operations

Data storage is normally implemented by using registers. However, when working with large amounts of fixed data, the volume involved often makes it inconvenient to store the fixed data in the Data Memory. To overcome this problem, Holtek microcontrollers allow an area of Program Memory to be set as a table where data can be directly stored. A set of easy to use instructions provides the means by which this fixed data can be referenced and retrieved from the Program Memory.

## Other Operations

In addition to the above functional instructions, a range of other instructions also exist such as the "HALT" instruction for Power-down operations and instructions to control the operation of the Watchdog Timer for reliable program operations under extreme electric or electromagnetic environments. For their relevant operations, refer to the functional related sections.

## Instruction Set Summary

The following table depicts a summary of the instruction set categorised according to function and can be consulted as a basic instruction reference using the following listed conventions.

### Table Conventions

x: Bits immediate data  
m: Data Memory address  
A: Accumulator  
i: 0~7 number of bits  
addr: Program memory address

| Mnemonic                         | Description   | Cycles            | Flag Affected        |
|----------------------------------|---|-------------------|----------------------|
| <b>Arithmetic</b>                |   |                   |                      |
| ADD A,[m]                        | Add Data Memory to ACC  | 1                 | Z, C, AC, OV, SC     |
| ADDM A,[m]                       | Add ACC to Data Memory  | 1 <sup>Note</sup> | Z, C, AC, OV, SC     |
| ADD A,x                          | Add immediate data to ACC                                       | 1                 | Z, C, AC, OV, SC     |
| ADC A,[m]                        | Add Data Memory to ACC with Carry                               | 1                 | Z, C, AC, OV, SC     |
| ADCM A,[m]                       | Add ACC to Data memory with Carry                               | 1 <sup>Note</sup> | Z, C, AC, OV, SC     |
| SUB A,x                          | Subtract immediate data from the ACC                            | 1                 | Z, C, AC, OV, SC, CZ |
| SUB A,[m]                        | Subtract Data Memory from ACC                                   | 1                 | Z, C, AC, OV, SC, CZ |
| SUBM A,[m]                       | Subtract Data Memory from ACC with result in Data Memory        | 1 <sup>Note</sup> | Z, C, AC, OV, SC, CZ |
| SBC A,x                          | Subtract immediate data from ACC with Carry                     | 1                 | Z, C, AC, OV, SC, CZ |
| SBC A,[m]                        | Subtract Data Memory from ACC with Carry                        | 1                 | Z, C, AC, OV, SC, CZ |
| SBCM A,[m]                       | Subtract Data Memory from ACC with Carry, result in Data Memory | 1 <sup>Note</sup> | Z, C, AC, OV, SC, CZ |
| DAA [m]                          | Decimal adjust ACC for Addition with result in Data Memory      | 1 <sup>Note</sup> | C                    |
| <b>Logic Operation</b>           |   |                   |                      |
| AND A,[m]                        | Logical AND Data Memory to ACC                                  | 1                 | Z                    |
| OR A,[m]                         | Logical OR Data Memory to ACC                                   | 1                 | Z                    |
| XOR A,[m]                        | Logical XOR Data Memory to ACC                                  | 1                 | Z                    |
| ANDM A,[m]                       | Logical AND ACC to Data Memory                                  | 1 <sup>Note</sup> | Z                    |
| ORM A,[m]                        | Logical OR ACC to Data Memory                                   | 1 <sup>Note</sup> | Z                    |
| XORM A,[m]                       | Logical XOR ACC to Data Memory                                  | 1 <sup>Note</sup> | Z                    |
| AND A,x                          | Logical AND immediate Data to ACC                               | 1                 | Z                    |
| OR A,x                           | Logical OR immediate Data to ACC                                | 1                 | Z                    |
| XOR A,x                          | Logical XOR immediate Data to ACC                               | 1                 | Z                    |
| CPL [m]                          | Complement Data Memory  | 1 <sup>Note</sup> | Z                    |
| CPLA [m]                         | Complement Data Memory with result in ACC                       | 1                 | Z                    |
| <b>Increment &amp; Decrement</b> |   |                   |                      |
| INCA [m]                         | Increment Data Memory with result in ACC                        | 1                 | Z                    |
| INC [m]                          | Increment Data Memory   | 1 <sup>Note</sup> | Z                    |
| DECA [m]                         | Decrement Data Memory with result in ACC                        | 1                 | Z                    |
| DEC [m]                          | Decrement Data Memory   | 1 <sup>Note</sup> | Z                    |
| <b>Rotate</b>                    |   |                   |                      |
| RRA [m]                          | Rotate Data Memory right with result in ACC                     | 1                 | None                 |
| RR [m]                           | Rotate Data Memory right  | 1 <sup>Note</sup> | None                 |
| RRCA [m]                         | Rotate Data Memory right through Carry with result in ACC       | 1                 | C                    |
| RRC [m]                          | Rotate Data Memory right through Carry                          | 1 <sup>Note</sup> | C                    |
| RLA [m]                          | Rotate Data Memory left with result in ACC                      | 1                 | None                 |
| RL [m]                           | Rotate Data Memory left   | 1 <sup>Note</sup> | None                 |
| RLCA [m]                         | Rotate Data Memory left through Carry with result in ACC        | 1                 | C                    |
| RLC [m]                          | Rotate Data Memory left through Carry                           | 1 <sup>Note</sup> | C                    |

| Mnemonic                    | Description   | Cycles            | Flag Affected |
|-----------------------------|---|-------------------|---------------|
| <b>Data Move</b>            |   |                   |               |
| MOV A,[m]                   | Move Data Memory to ACC   | 1                 | None          |
| MOV [m],A                   | Move ACC to Data Memory   | 1 <sup>Note</sup> | None          |
| MOV A,x                     | Move immediate data to ACC  | 1                 | None          |
| <b>Bit Operation</b>        |   |                   |               |
| CLR [m].i                   | Clear bit of Data Memory  | 1 <sup>Note</sup> | None          |
| SET [m].i                   | Set bit of Data Memory  | 1 <sup>Note</sup> | None          |
| <b>Branch Operation</b>     |   |                   |               |
| JMP addr                    | Jump unconditionally  | 2                 | None          |
| SZ [m]                      | Skip if Data Memory is zero   | 1 <sup>Note</sup> | None          |
| SZA [m]                     | Skip if Data Memory is zero with data movement to ACC                                 | 1 <sup>Note</sup> | None          |
| SZ [m].i                    | Skip if bit i of Data Memory is zero  | 1 <sup>Note</sup> | None          |
| SNZ [m]                     | Skip if Data Memory is not zero   | 1 <sup>Note</sup> | None          |
| SNZ [m].i                   | Skip if bit i of Data Memory is not zero  | 1 <sup>Note</sup> | None          |
| SIZ [m]                     | Skip if increment Data Memory is zero   | 1 <sup>Note</sup> | None          |
| SDZ [m]                     | Skip if decrement Data Memory is zero   | 1 <sup>Note</sup> | None          |
| SIZA [m]                    | Skip if increment Data Memory is zero with result in ACC                              | 1 <sup>Note</sup> | None          |
| SDZA [m]                    | Skip if decrement Data Memory is zero with result in ACC                              | 1 <sup>Note</sup> | None          |
| CALL addr                   | Subroutine call   | 2                 | None          |
| RET                         | Return from subroutine  | 2                 | None          |
| RET A,x                     | Return from subroutine and load immediate data to ACC                                 | 2                 | None          |
| RETI                        | Return from interrupt   | 2                 | None          |
| <b>Table Read Operation</b> |   |                   |               |
| TABRD [m]                   | Read table (specific page) to TBLH and Data Memory                                    | 2 <sup>Note</sup> | None          |
| TABRDL [m]                  | Read table (last page) to TBLH and Data Memory  | 2 <sup>Note</sup> | None          |
| ITABRD [m]                  | Increment table pointer TBLP first and Read table to TBLH and Data Memory             | 2 <sup>Note</sup> | None          |
| ITABRDL [m]                 | Increment table pointer TBLP first and Read table (last page) to TBLH and Data Memory | 2 <sup>Note</sup> | None          |
| <b>Miscellaneous</b>        |   |                   |               |
| NOP                         | No operation  | 1                 | None          |
| CLR [m]                     | Clear Data Memory   | 1 <sup>Note</sup> | None          |
| SET [m]                     | Set Data Memory   | 1 <sup>Note</sup> | None          |
| CLR WDT                     | Clear Watchdog Timer  | 1                 | TO, PDF       |
| SWAP [m]                    | Swap nibbles of Data Memory   | 1 <sup>Note</sup> | None          |
| SWAPA [m]                   | Swap nibbles of Data Memory with result in ACC  | 1                 | None          |
| HALT                        | Enter power down mode   | 1                 | TO, PDF       |

Note: 1. For skip instructions, if the result of the comparison involves a skip then up to three cycles are required, if no skip takes place only one cycle is required.

2. Any instruction which changes the contents of the PCL will also require 2 cycles for execution.

3. For the “CLR WDT” instruction the TO and PDF flags may be affected by the execution status. The TO and PDF flags are cleared after the “CLR WDT” instructions is executed. Otherwise the TO and PDF flags remain unchanged.

## Extended Instruction Set

The extended instructions are used to support the full range address access for the data memory. When the accessed data memory is located in any data memory sector except sector 0, the extended instruction can be used to directly access the data memory instead of using the indirect addressing access. This can not only reduce the use of Flash memory space but also improve the CPU execution efficiency.

| Mnemonic                         | Description   | Cycles            | Flag Affected        |
|----------------------------------|---|-------------------|----------------------|
| <b>Arithmetic</b>                |   |                   |                      |
| LADD A,[m]                       | Add Data Memory to ACC  | 2                 | Z, C, AC, OV, SC     |
| LADDM A,[m]                      | Add ACC to Data Memory  | 2 <sup>Note</sup> | Z, C, AC, OV, SC     |
| LADC A,[m]                       | Add Data Memory to ACC with Carry                               | 2                 | Z, C, AC, OV, SC     |
| LADCM A,[m]                      | Add ACC to Data memory with Carry                               | 2 <sup>Note</sup> | Z, C, AC, OV, SC     |
| LSUB A,[m]                       | Subtract Data Memory from ACC                                   | 2                 | Z, C, AC, OV, SC, CZ |
| LSUBM A,[m]                      | Subtract Data Memory from ACC with result in Data Memory        | 2 <sup>Note</sup> | Z, C, AC, OV, SC, CZ |
| LSBC A,[m]                       | Subtract Data Memory from ACC with Carry                        | 2                 | Z, C, AC, OV, SC, CZ |
| LSBCM A,[m]                      | Subtract Data Memory from ACC with Carry, result in Data Memory | 2 <sup>Note</sup> | Z, C, AC, OV, SC, CZ |
| LDAA [m]                         | Decimal adjust ACC for Addition with result in Data Memory      | 2 <sup>Note</sup> | C                    |
| <b>Logic Operation</b>           |   |                   |                      |
| LAND A,[m]                       | Logical AND Data Memory to ACC                                  | 2                 | Z                    |
| LOR A,[m]                        | Logical OR Data Memory to ACC                                   | 2                 | Z                    |
| LXOR A,[m]                       | Logical XOR Data Memory to ACC                                  | 2                 | Z                    |
| LANDM A,[m]                      | Logical AND ACC to Data Memory                                  | 2 <sup>Note</sup> | Z                    |
| LORM A,[m]                       | Logical OR ACC to Data Memory                                   | 2 <sup>Note</sup> | Z                    |
| LXORM A,[m]                      | Logical XOR ACC to Data Memory                                  | 2 <sup>Note</sup> | Z                    |
| LCPL [m]                         | Complement Data Memory  | 2 <sup>Note</sup> | Z                    |
| LCPLA [m]                        | Complement Data Memory with result in ACC                       | 2                 | Z                    |
| <b>Increment &amp; Decrement</b> |   |                   |                      |
| LINCA [m]                        | Increment Data Memory with result in ACC                        | 2                 | Z                    |
| LINC [m]                         | Increment Data Memory   | 2 <sup>Note</sup> | Z                    |
| LDECA [m]                        | Decrement Data Memory with result in ACC                        | 2                 | Z                    |
| LDEC [m]                         | Decrement Data Memory   | 2 <sup>Note</sup> | Z                    |
| <b>Rotate</b>                    |   |                   |                      |
| LRRRA [m]                        | Rotate Data Memory right with result in ACC                     | 2                 | None                 |
| LRR [m]                          | Rotate Data Memory right  | 2 <sup>Note</sup> | None                 |
| LRRCA [m]                        | Rotate Data Memory right through Carry with result in ACC       | 2                 | C                    |
| LRRC [m]                         | Rotate Data Memory right through Carry                          | 2 <sup>Note</sup> | C                    |
| LRLA [m]                         | Rotate Data Memory left with result in ACC                      | 2                 | None                 |
| LRL [m]                          | Rotate Data Memory left   | 2 <sup>Note</sup> | None                 |
| LRLCA [m]                        | Rotate Data Memory left through Carry with result in ACC        | 2                 | C                    |
| LRLC [m]                         | Rotate Data Memory left through Carry                           | 2 <sup>Note</sup> | C                    |
| <b>Data Move</b>                 |   |                   |                      |
| LMOV A,[m]                       | Move Data Memory to ACC   | 2                 | None                 |
| LMOV [m],A                       | Move ACC to Data Memory   | 2 <sup>Note</sup> | None                 |
| <b>Bit Operation</b>             |   |                   |                      |
| LCLR [m].i                       | Clear bit of Data Memory  | 2 <sup>Note</sup> | None                 |
| LSET [m].i                       | Set bit of Data Memory  | 2 <sup>Note</sup> | None                 |

| Mnemonic             | Description   | Cycles            | Flag Affected |
|----------------------|---|-------------------|---------------|
| <b>Branch</b>        |   |                   |               |
| LSZ [m]              | Skip if Data Memory is zero   | 2 <sup>Note</sup> | None          |
| LSZA [m]             | Skip if Data Memory is zero with data movement to ACC                                 | 2 <sup>Note</sup> | None          |
| LSNZ [m]             | Skip if Data Memory is not zero   | 2 <sup>Note</sup> | None          |
| LSZ [m].i            | Skip if bit i of Data Memory is zero  | 2 <sup>Note</sup> | None          |
| LSNZ [m].i           | Skip if bit i of Data Memory is not zero  | 2 <sup>Note</sup> | None          |
| LSIZ [m]             | Skip if increment Data Memory is zero   | 2 <sup>Note</sup> | None          |
| LSDZ [m]             | Skip if decrement Data Memory is zero   | 2 <sup>Note</sup> | None          |
| LSIZA [m]            | Skip if increment Data Memory is zero with result in ACC                              | 2 <sup>Note</sup> | None          |
| LSDZA [m]            | Skip if decrement Data Memory is zero with result in ACC                              | 2 <sup>Note</sup> | None          |
| <b>Table Read</b>    |   |                   |               |
| LTABRD [m]           | Read table to TBLH and Data Memory  | 3 <sup>Note</sup> | None          |
| LTABRDL [m]          | Read table (last page) to TBLH and Data Memory  | 3 <sup>Note</sup> | None          |
| LITABRD [m]          | Increment table pointer TBLP first and Read table to TBLH and Data Memory             | 3 <sup>Note</sup> | None          |
| LITABRDL [m]         | Increment table pointer TBLP first and Read table (last page) to TBLH and Data Memory | 3 <sup>Note</sup> | None          |
| <b>Miscellaneous</b> |   |                   |               |
| LCLR [m]             | Clear Data Memory   | 2 <sup>Note</sup> | None          |
| LSET [m]             | Set Data Memory   | 2 <sup>Note</sup> | None          |
| LSWAP [m]            | Swap nibbles of Data Memory   | 2 <sup>Note</sup> | None          |
| LSWAPA [m]           | Swap nibbles of Data Memory with result in ACC  | 2                 | None          |

Note: 1. For these extended skip instructions, if the result of the comparison involves a skip then up to four cycles are required, if no skip takes place two cycles is required.

2. Any extended instruction which changes the contents of the PCL register will also require three cycles for execution.

## Instruction Definition

|                   |   |
|-------------------|---|
| <b>ADC A,[m]</b>  | Add Data Memory to ACC with Carry   |
| Description       | The contents of the specified Data Memory, Accumulator and the carry flag are added. The result is stored in the Accumulator.               |
| Operation         | $ACC \leftarrow ACC + [m] + C$  |
| Affected flag(s)  | OV, Z, AC, C, SC  |
| <b>ADCM A,[m]</b> | Add ACC to Data Memory with Carry   |
| Description       | The contents of the specified Data Memory, Accumulator and the carry flag are added. The result is stored in the specified Data Memory.     |
| Operation         | $[m] \leftarrow ACC + [m] + C$  |
| Affected flag(s)  | OV, Z, AC, C, SC  |
| <b>ADD A,[m]</b>  | Add Data Memory to ACC  |
| Description       | The contents of the specified Data Memory and the Accumulator are added. The result is stored in the Accumulator.                           |
| Operation         | $ACC \leftarrow ACC + [m]$  |
| Affected flag(s)  | OV, Z, AC, C, SC  |
| <b>ADD A,x</b>    | Add immediate data to ACC   |
| Description       | The contents of the Accumulator and the specified immediate data are added. The result is stored in the Accumulator.                        |
| Operation         | $ACC \leftarrow ACC + x$  |
| Affected flag(s)  | OV, Z, AC, C, SC  |
| <b>ADDM A,[m]</b> | Add ACC to Data Memory  |
| Description       | The contents of the specified Data Memory and the Accumulator are added. The result is stored in the specified Data Memory.                 |
| Operation         | $[m] \leftarrow ACC + [m]$  |
| Affected flag(s)  | OV, Z, AC, C, SC  |
| <b>AND A,[m]</b>  | Logical AND Data Memory to ACC  |
| Description       | Data in the Accumulator and the specified Data Memory perform a bitwise logical AND operation. The result is stored in the Accumulator.     |
| Operation         | $ACC \leftarrow ACC \text{ "AND" } [m]$   |
| Affected flag(s)  | Z   |
| <b>AND A,x</b>    | Logical AND immediate data to ACC   |
| Description       | Data in the Accumulator and the specified immediate data perform a bit wise logical AND operation. The result is stored in the Accumulator. |
| Operation         | $ACC \leftarrow ACC \text{ "AND" } x$   |
| Affected flag(s)  | Z   |
| <b>ANDM A,[m]</b> | Logical AND ACC to Data Memory  |
| Description       | Data in the specified Data Memory and the Accumulator perform a bitwise logical AND operation. The result is stored in the Data Memory.     |
| Operation         | $[m] \leftarrow ACC \text{ "AND" } [m]$   |
| Affected flag(s)  | Z   |

|                  |  |
|------------------|--|
| <b>CALL addr</b> | Subroutine call  |
| Description      | Unconditionally calls a subroutine at the specified address. The Program Counter then increments by 1 to obtain the address of the next instruction which is then pushed onto the stack. The specified address is then loaded and the program continues execution from this new address. As this instruction requires an additional operation, it is a two cycle instruction.  |
| Operation        | Stack $\leftarrow$ Program Counter + 1<br>Program Counter $\leftarrow$ addr  |
| Affected flag(s) | None   |
| <b>CLR [m]</b>   | Clear Data Memory  |
| Description      | Each bit of the specified Data Memory is cleared to 0.   |
| Operation        | [m] $\leftarrow$ 00H   |
| Affected flag(s) | None   |
| <b>CLR [m].i</b> | Clear bit of Data Memory   |
| Description      | Bit i of the specified Data Memory is cleared to 0.  |
| Operation        | [m].i $\leftarrow$ 0   |
| Affected flag(s) | None   |
| <b>CLR WDT</b>   | Clear Watchdog Timer   |
| Description      | The TO, PDF flags and the WDT are all cleared.   |
| Operation        | WDT cleared<br>TO $\leftarrow$ 0<br>PDF $\leftarrow$ 0   |
| Affected flag(s) | TO, PDF  |
| <b>CPL [m]</b>   | Complement Data Memory   |
| Description      | Each bit of the specified Data Memory is logically complemented (1's complement). Bits which previously contained a 1 are changed to 0 and vice versa.   |
| Operation        | [m] $\leftarrow$ $\overline{[m]}$  |
| Affected flag(s) | Z  |
| <b>CPLA [m]</b>  | Complement Data Memory with result in ACC  |
| Description      | Each bit of the specified Data Memory is logically complemented (1's complement). Bits which previously contained a 1 are changed to 0 and vice versa. The complemented result is stored in the Accumulator and the contents of the Data Memory remain unchanged.  |
| Operation        | ACC $\leftarrow$ $\overline{[m]}$  |
| Affected flag(s) | Z  |
| <b>DAA [m]</b>   | Decimal-Adjust ACC for addition with result in Data Memory   |
| Description      | Convert the contents of the Accumulator value to a BCD (Binary Coded Decimal) value resulting from the previous addition of two BCD variables. If the low nibble is greater than 9 or if AC flag is set, then a value of 6 will be added to the low nibble. Otherwise the low nibble remains unchanged. If the high nibble is greater than 9 or if the C flag is set, then a value of 6 will be added to the high nibble. Essentially, the decimal conversion is performed by adding 00H, 06H, 60H or 66H depending on the Accumulator and flag conditions. Only the C flag may be affected by this instruction which indicates that if the original BCD sum is greater than 100, it allows multiple precision decimal addition. |
| Operation        | [m] $\leftarrow$ ACC + 00H or<br>[m] $\leftarrow$ ACC + 06H or<br>[m] $\leftarrow$ ACC + 60H or<br>[m] $\leftarrow$ ACC + 66H  |
| Affected flag(s) | C  |

|                  |  |
|------------------|--|
| <b>DEC [m]</b>   | Decrement Data Memory  |
| Description      | Data in the specified Data Memory is decremented by 1.   |
| Operation        | $[m] \leftarrow [m] - 1$   |
| Affected flag(s) | Z  |
| <br>             |  |
| <b>DECA [m]</b>  | Decrement Data Memory with result in ACC   |
| Description      | Data in the specified Data Memory is decremented by 1. The result is stored in the Accumulator. The contents of the Data Memory remain unchanged.  |
| Operation        | $ACC \leftarrow [m] - 1$   |
| Affected flag(s) | Z  |
| <br>             |  |
| <b>HALT</b>      | Enter power down mode  |
| Description      | This instruction stops the program execution and turns off the system clock. The contents of the Data Memory and registers are retained. The WDT and prescaler are cleared. The power down flag PDF is set and the WDT time-out flag TO is cleared.        |
| Operation        | $TO \leftarrow 0$<br>$PDF \leftarrow 1$  |
| Affected flag(s) | TO, PDF  |
| <br>             |  |
| <b>INC [m]</b>   | Increment Data Memory  |
| Description      | Data in the specified Data Memory is incremented by 1.   |
| Operation        | $[m] \leftarrow [m] + 1$   |
| Affected flag(s) | Z  |
| <br>             |  |
| <b>INCA [m]</b>  | Increment Data Memory with result in ACC   |
| Description      | Data in the specified Data Memory is incremented by 1. The result is stored in the Accumulator. The contents of the Data Memory remain unchanged.  |
| Operation        | $ACC \leftarrow [m] + 1$   |
| Affected flag(s) | Z  |
| <br>             |  |
| <b>JMP addr</b>  | Jump unconditionally   |
| Description      | The contents of the Program Counter are replaced with the specified address. Program execution then continues from this new address. As this requires the insertion of a dummy instruction while the new address is loaded, it is a two cycle instruction. |
| Operation        | Program Counter $\leftarrow$ addr  |
| Affected flag(s) | None   |
| <br>             |  |
| <b>MOV A,[m]</b> | Move Data Memory to ACC  |
| Description      | The contents of the specified Data Memory are copied to the Accumulator.   |
| Operation        | $ACC \leftarrow [m]$   |
| Affected flag(s) | None   |
| <br>             |  |
| <b>MOV A,x</b>   | Move immediate data to ACC   |
| Description      | The immediate data specified is loaded into the Accumulator.   |
| Operation        | $ACC \leftarrow x$   |
| Affected flag(s) | None   |
| <br>             |  |
| <b>MOV [m],A</b> | Move ACC to Data Memory  |
| Description      | The contents of the Accumulator are copied to the specified Data Memory.   |
| Operation        | $[m] \leftarrow ACC$   |
| Affected flag(s) | None   |

|                  |  |
|------------------|--|
| <b>NOP</b>       | No operation   |
| Description      | No operation is performed. Execution continues with the next instruction.  |
| Operation        | No operation   |
| Affected flag(s) | None   |
| <br>             |  |
| <b>OR A,[m]</b>  | Logical OR Data Memory to ACC  |
| Description      | Data in the Accumulator and the specified Data Memory perform a bitwise logical OR operation. The result is stored in the Accumulator.   |
| Operation        | ACC ← ACC "OR" [m]   |
| Affected flag(s) | Z  |
| <br>             |  |
| <b>OR A,x</b>    | Logical OR immediate data to ACC   |
| Description      | Data in the Accumulator and the specified immediate data perform a bitwise logical OR operation. The result is stored in the Accumulator.  |
| Operation        | ACC ← ACC "OR" x   |
| Affected flag(s) | Z  |
| <br>             |  |
| <b>ORM A,[m]</b> | Logical OR ACC to Data Memory  |
| Description      | Data in the specified Data Memory and the Accumulator perform a bitwise logical OR operation. The result is stored in the Data Memory.   |
| Operation        | [m] ← ACC "OR" [m]   |
| Affected flag(s) | Z  |
| <br>             |  |
| <b>RET</b>       | Return from subroutine   |
| Description      | The Program Counter is restored from the stack. Program execution continues at the restored address.   |
| Operation        | Program Counter ← Stack  |
| Affected flag(s) | None   |
| <br>             |  |
| <b>RET A,x</b>   | Return from subroutine and load immediate data to ACC  |
| Description      | The Program Counter is restored from the stack and the Accumulator loaded with the specified immediate data. Program execution continues at the restored address.  |
| Operation        | Program Counter ← Stack<br>ACC ← x   |
| Affected flag(s) | None   |
| <br>             |  |
| <b>RETI</b>      | Return from interrupt  |
| Description      | The Program Counter is restored from the stack and the interrupts are re-enabled by setting the EMI bit. EMI is the master interrupt global enable bit. If an interrupt was pending when the RETI instruction is executed, the pending Interrupt routine will be processed before returning to the main program. |
| Operation        | Program Counter ← Stack<br>EMI ← 1   |
| Affected flag(s) | None   |
| <br>             |  |
| <b>RL [m]</b>    | Rotate Data Memory left  |
| Description      | The contents of the specified Data Memory are rotated left by 1 bit with bit 7 rotated into bit 0.   |
| Operation        | [m].(i+1) ← [m].i; (i=0~6)<br>[m].0 ← [m].7  |
| Affected flag(s) | None   |

|                  |   |
|------------------|---|
| <b>RLA [m]</b>   | Rotate Data Memory left with result in ACC  |
| Description      | The contents of the specified Data Memory are rotated left by 1 bit with bit 7 rotated into bit 0. The rotated result is stored in the Accumulator and the contents of the Data Memory remain unchanged.  |
| Operation        | ACC.(i+1) ← [m].i; (i=0~6)<br>ACC.0 ← [m].7   |
| Affected flag(s) | None  |
| <b>RLC [m]</b>   | Rotate Data Memory left through Carry   |
| Description      | The contents of the specified Data Memory and the carry flag are rotated left by 1 bit. Bit 7 replaces the Carry bit and the original carry flag is rotated into bit 0.   |
| Operation        | [m].(i+1) ← [m].i; (i=0~6)<br>[m].0 ← C<br>C ← [m].7  |
| Affected flag(s) | C   |
| <b>RLCA [m]</b>  | Rotate Data Memory left through Carry with result in ACC  |
| Description      | Data in the specified Data Memory and the carry flag are rotated left by 1 bit. Bit 7 replaces the Carry bit and the original carry flag is rotated into the bit 0. The rotated result is stored in the Accumulator and the contents of the Data Memory remain unchanged. |
| Operation        | ACC.(i+1) ← [m].i; (i=0~6)<br>ACC.0 ← C<br>C ← [m].7  |
| Affected flag(s) | C   |
| <b>RR [m]</b>    | Rotate Data Memory right  |
| Description      | The contents of the specified Data Memory are rotated right by 1 bit with bit 0 rotated into bit 7.   |
| Operation        | [m].i ← [m].(i+1); (i=0~6)<br>[m].7 ← [m].0   |
| Affected flag(s) | None  |
| <b>RRA [m]</b>   | Rotate Data Memory right with result in ACC   |
| Description      | Data in the specified Data Memory is rotated right by 1 bit with bit 0 rotated into bit 7. The rotated result is stored in the Accumulator and the contents of the Data Memory remain unchanged.  |
| Operation        | ACC.i ← [m].(i+1); (i=0~6)<br>ACC.7 ← [m].0   |
| Affected flag(s) | None  |
| <b>RRC [m]</b>   | Rotate Data Memory right through Carry  |
| Description      | The contents of the specified Data Memory and the carry flag are rotated right by 1 bit. Bit 0 replaces the Carry bit and the original carry flag is rotated into bit 7.  |
| Operation        | [m].i ← [m].(i+1); (i=0~6)<br>[m].7 ← C<br>C ← [m].0  |
| Affected flag(s) | C   |

|                   |   |
|-------------------|---|
| <b>RRCA [m]</b>   | Rotate Data Memory right through Carry with result in ACC   |
| Description       | Data in the specified Data Memory and the carry flag are rotated right by 1 bit. Bit 0 replaces the Carry bit and the original carry flag is rotated into bit 7. The rotated result is stored in the Accumulator and the contents of the Data Memory remain unchanged.  |
| Operation         | ACC.i ← [m].(i+1); (i=0~6)<br>ACC.7 ← C<br>C ← [m].0  |
| Affected flag(s)  | C   |
| <b>SBC A,[m]</b>  | Subtract Data Memory from ACC with Carry  |
| Description       | The contents of the specified Data Memory and the complement of the carry flag are subtracted from the Accumulator. The result is stored in the Accumulator. Note that if the result of subtraction is negative, the C flag will be cleared to 0, otherwise if the result is positive or zero, the C flag will be set to 1.   |
| Operation         | ACC ← ACC - [m] - $\bar{C}$   |
| Affected flag(s)  | OV, Z, AC, C, SC, CZ  |
| <b>SBC A, x</b>   | Subtract immediate data from ACC with Carry   |
| Description       | The immediate data and the complement of the carry flag are subtracted from the Accumulator. The result is stored in the Accumulator. Note that if the result of subtraction is negative, the C flag will be cleared to 0, otherwise if the result is positive or zero, the C flag will be set to 1.  |
| Operation         | ACC ← ACC - [m] - $\bar{C}$   |
| Affected flag(s)  | OV, Z, AC, C, SC, CZ  |
| <b>SBCM A,[m]</b> | Subtract Data Memory from ACC with Carry and result in Data Memory  |
| Description       | The contents of the specified Data Memory and the complement of the carry flag are subtracted from the Accumulator. The result is stored in the Data Memory. Note that if the result of subtraction is negative, the C flag will be cleared to 0, otherwise if the result is positive or zero, the C flag will be set to 1.   |
| Operation         | [m] ← ACC - [m] - $\bar{C}$   |
| Affected flag(s)  | OV, Z, AC, C, SC, CZ  |
| <b>SDZ [m]</b>    | Skip if decrement Data Memory is 0  |
| Description       | The contents of the specified Data Memory are first decremented by 1. If the result is 0 the following instruction is skipped. As this requires the insertion of a dummy instruction while the next instruction is fetched, it is a two cycle instruction. If the result is not 0 the program proceeds with the following instruction.  |
| Operation         | [m] ← [m] - 1<br>Skip if [m]=0  |
| Affected flag(s)  | None  |
| <b>SDZA [m]</b>   | Skip if decrement Data Memory is zero with result in ACC  |
| Description       | The contents of the specified Data Memory are first decremented by 1. If the result is 0, the following instruction is skipped. The result is stored in the Accumulator but the specified Data Memory contents remain unchanged. As this requires the insertion of a dummy instruction while the next instruction is fetched, it is a two cycle instruction. If the result is not 0, the program proceeds with the following instruction. |
| Operation         | ACC ← [m] - 1<br>Skip if ACC=0  |
| Affected flag(s)  | None  |

|                  |  |
|------------------|--|
| <b>SET [m]</b>   | Set Data Memory  |
| Description      | Each bit of the specified Data Memory is set to 1.   |
| Operation        | $[m] \leftarrow FFH$   |
| Affected flag(s) | None   |
| <br>             |  |
| <b>SET [m].i</b> | Set bit of Data Memory   |
| Description      | Bit i of the specified Data Memory is set to 1.  |
| Operation        | $[m].i \leftarrow 1$   |
| Affected flag(s) | None   |
| <br>             |  |
| <b>SIZ [m]</b>   | Skip if increment Data Memory is 0   |
| Description      | The contents of the specified Data Memory are first incremented by 1. If the result is 0, the following instruction is skipped. As this requires the insertion of a dummy instruction while the next instruction is fetched, it is a two cycle instruction. If the result is not 0 the program proceeds with the following instruction.  |
| Operation        | $[m] \leftarrow [m] + 1$<br>Skip if $[m]=0$  |
| Affected flag(s) | None   |
| <br>             |  |
| <b>SIZA [m]</b>  | Skip if increment Data Memory is zero with result in ACC   |
| Description      | The contents of the specified Data Memory are first incremented by 1. If the result is 0, the following instruction is skipped. The result is stored in the Accumulator but the specified Data Memory contents remain unchanged. As this requires the insertion of a dummy instruction while the next instruction is fetched, it is a two cycle instruction. If the result is not 0 the program proceeds with the following instruction. |
| Operation        | $ACC \leftarrow [m] + 1$<br>Skip if $ACC=0$  |
| Affected flag(s) | None   |
| <br>             |  |
| <b>SNZ [m].i</b> | Skip if Data Memory is not 0   |
| Description      | If the specified Data Memory is not 0, the following instruction is skipped. As this requires the insertion of a dummy instruction while the next instruction is fetched, it is a two cycle instruction. If the result is 0 the program proceeds with the following instruction.   |
| Operation        | Skip if $[m].i \neq 0$   |
| Affected flag(s) | None   |
| <br>             |  |
| <b>SNZ [m]</b>   | Skip if Data Memory is not 0   |
| Description      | If the specified Data Memory is not 0, the following instruction is skipped. As this requires the insertion of a dummy instruction while the next instruction is fetched, it is a two cycle instruction. If the result is 0 the program proceeds with the following instruction.   |
| Operation        | Skip if $[m] \neq 0$   |
| Affected flag(s) | None   |
| <br>             |  |
| <b>SUB A,[m]</b> | Subtract Data Memory from ACC  |
| Description      | The specified Data Memory is subtracted from the contents of the Accumulator. The result is stored in the Accumulator. Note that if the result of subtraction is negative, the C flag will be cleared to 0, otherwise if the result is positive or zero, the C flag will be set to 1.  |
| Operation        | $ACC \leftarrow ACC - [m]$   |
| Affected flag(s) | OV, Z, AC, C, SC, CZ   |

|                   |  |
|-------------------|--|
| <b>SUBM A,[m]</b> | Subtract Data Memory from ACC with result in Data Memory   |
| Description       | The specified Data Memory is subtracted from the contents of the Accumulator. The result is stored in the Data Memory. Note that if the result of subtraction is negative, the C flag will be cleared to 0, otherwise if the result is positive or zero, the C flag will be set to 1.  |
| Operation         | $[m] \leftarrow ACC - [m]$   |
| Affected flag(s)  | OV, Z, AC, C, SC, CZ   |
| <b>SUB A,x</b>    | Subtract immediate data from ACC   |
| Description       | The immediate data specified by the code is subtracted from the contents of the Accumulator. The result is stored in the Accumulator. Note that if the result of subtraction is negative, the C flag will be cleared to 0, otherwise if the result is positive or zero, the C flag will be set to 1.   |
| Operation         | $ACC \leftarrow ACC - x$   |
| Affected flag(s)  | OV, Z, AC, C, SC, CZ   |
| <b>SWAP [m]</b>   | Swap nibbles of Data Memory  |
| Description       | The low-order and high-order nibbles of the specified Data Memory are interchanged.  |
| Operation         | $[m].3 \sim [m].0 \leftrightarrow [m].7 \sim [m].4$  |
| Affected flag(s)  | None   |
| <b>SWAPA [m]</b>  | Swap nibbles of Data Memory with result in ACC   |
| Description       | The low-order and high-order nibbles of the specified Data Memory are interchanged. The result is stored in the Accumulator. The contents of the Data Memory remain unchanged.   |
| Operation         | $ACC.3 \sim ACC.0 \leftarrow [m].7 \sim [m].4$<br>$ACC.7 \sim ACC.4 \leftarrow [m].3 \sim [m].0$   |
| Affected flag(s)  | None   |
| <b>SZ [m]</b>     | Skip if Data Memory is 0   |
| Description       | If the contents of the specified Data Memory is 0, the following instruction is skipped. As this requires the insertion of a dummy instruction while the next instruction is fetched, it is a two cycle instruction. If the result is not 0 the program proceeds with the following instruction.   |
| Operation         | Skip if $[m]=0$  |
| Affected flag(s)  | None   |
| <b>SZA [m]</b>    | Skip if Data Memory is 0 with data movement to ACC   |
| Description       | The contents of the specified Data Memory are copied to the Accumulator. If the value is zero, the following instruction is skipped. As this requires the insertion of a dummy instruction while the next instruction is fetched, it is a two cycle instruction. If the result is not 0 the program proceeds with the following instruction. |
| Operation         | $ACC \leftarrow [m]$<br>Skip if $[m]=0$  |
| Affected flag(s)  | None   |
| <b>SZ [m].i</b>   | Skip if bit i of Data Memory is 0  |
| Description       | If bit i of the specified Data Memory is 0, the following instruction is skipped. As this requires the insertion of a dummy instruction while the next instruction is fetched, it is a two cycle instruction. If the result is not 0, the program proceeds with the following instruction.   |
| Operation         | Skip if $[m].i=0$  |
| Affected flag(s)  | None   |

|                    |  |
|--------------------|--|
| <b>TABRD [m]</b>   | Read table (specific page) to TBLH and Data Memory   |
| Description        | The low byte of the program code (specific page) addressed by the table pointer pair (TBLP and TBHP) is moved to the specified Data Memory and the high byte moved to TBLH.                                      |
| Operation          | [m] ← program code (low byte)<br>TBLH ← program code (high byte)   |
| Affected flag(s)   | None   |
|                    |  |
| <b>TABRDL [m]</b>  | Read table (last page) to TBLH and Data Memory   |
| Description        | The low byte of the program code (last page) addressed by the table pointer (TBLP) is moved to the specified Data Memory and the high byte moved to TBLH.  |
| Operation          | [m] ← program code (low byte)<br>TBLH ← program code (high byte)   |
| Affected flag(s)   | None   |
|                    |  |
| <b>ITABRD [m]</b>  | Increment table pointer low byte first and read table to TBLH and Data Memory  |
| Description        | Increment table pointer low byte, TBLP, first and then the program code addressed by the table pointer (TBHP and TBLP) is moved to the specified Data Memory and the high byte moved to TBLH.                    |
| Operation          | [m] ← program code (low byte)<br>TBLH ← program code (high byte)   |
| Affected flag(s)   | None   |
|                    |  |
| <b>ITABRDL [m]</b> | Increment table pointer low byte first and read table (last page) to TBLH and Data Memory  |
| Description        | Increment table pointer low byte, TBLP, first and then the low byte of the program code (last page) addressed by the table pointer (TBLP) is moved to the specified Data Memory and the high byte moved to TBLH. |
| Operation          | [m] ← program code (low byte)<br>TBLH ← program code (high byte)   |
| Affected flag(s)   | None   |
|                    |  |
| <b>XOR A,[m]</b>   | Logical XOR Data Memory to ACC   |
| Description        | Data in the Accumulator and the specified Data Memory perform a bitwise logical XOR operation. The result is stored in the Accumulator.  |
| Operation          | ACC ← ACC "XOR" [m]  |
| Affected flag(s)   | Z  |
|                    |  |
| <b>XORM A,[m]</b>  | Logical XOR ACC to Data Memory   |
| Description        | Data in the specified Data Memory and the Accumulator perform a bitwise logical XOR operation. The result is stored in the Data Memory.  |
| Operation          | [m] ← ACC "XOR" [m]  |
| Affected flag(s)   | Z  |
|                    |  |
| <b>XOR A,x</b>     | Logical XOR immediate data to ACC  |
| Description        | Data in the Accumulator and the specified immediate data perform a bitwise logical XOR operation. The result is stored in the Accumulator.   |
| Operation          | ACC ← ACC "XOR" x  |
| Affected flag(s)   | Z  |

## Extended Instruction Definition

The extended instructions are used to directly access the data stored in any data memory sections.

|                    |   |
|--------------------|---|
| <b>LADC A,[m]</b>  | Add Data Memory to ACC with Carry   |
| Description        | The contents of the specified Data Memory, Accumulator and the carry flag are added. The result is stored in the Accumulator.           |
| Operation          | $ACC \leftarrow ACC + [m] + C$  |
| Affected flag(s)   | OV, Z, AC, C, SC  |
| <b>LADCM A,[m]</b> | Add ACC to Data Memory with Carry   |
| Description        | The contents of the specified Data Memory, Accumulator and the carry flag are added. The result is stored in the specified Data Memory. |
| Operation          | $[m] \leftarrow ACC + [m] + C$  |
| Affected flag(s)   | OV, Z, AC, C, SC  |
| <b>LADD A,[m]</b>  | Add Data Memory to ACC  |
| Description        | The contents of the specified Data Memory and the Accumulator are added. The result is stored in the Accumulator.                       |
| Operation          | $ACC \leftarrow ACC + [m]$  |
| Affected flag(s)   | OV, Z, AC, C, SC  |
| <b>LADDM A,[m]</b> | Add ACC to Data Memory  |
| Description        | The contents of the specified Data Memory and the Accumulator are added. The result is stored in the specified Data Memory.             |
| Operation          | $[m] \leftarrow ACC + [m]$  |
| Affected flag(s)   | OV, Z, AC, C, SC  |
| <b>LAND A,[m]</b>  | Logical AND Data Memory to ACC  |
| Description        | Data in the Accumulator and the specified Data Memory perform a bitwise logical AND operation. The result is stored in the Accumulator. |
| Operation          | $ACC \leftarrow ACC \text{ "AND" } [m]$   |
| Affected flag(s)   | Z   |
| <b>LANDM A,[m]</b> | Logical AND ACC to Data Memory  |
| Description        | Data in the specified Data Memory and the Accumulator perform a bitwise logical AND operation. The result is stored in the Data Memory. |
| Operation          | $[m] \leftarrow ACC \text{ "AND" } [m]$   |
| Affected flag(s)   | Z   |
| <b>LCLR [m]</b>    | Clear Data Memory   |
| Description        | Each bit of the specified Data Memory is cleared to 0.  |
| Operation          | $[m] \leftarrow 00H$  |
| Affected flag(s)   | None  |
| <b>LCLR [m].i</b>  | Clear bit of Data Memory  |
| Description        | Bit i of the specified Data Memory is cleared to 0.   |
| Operation          | $[m].i \leftarrow 0$  |
| Affected flag(s)   | None  |

|                  |  |
|------------------|--|
| <b>LCPL [m]</b>  | Complement Data Memory   |
| Description      | Each bit of the specified Data Memory is logically complemented (1's complement). Bits which previously contained a 1 are changed to 0 and vice versa.   |
| Operation        | $[m] \leftarrow \overline{[m]}$  |
| Affected flag(s) | Z  |
| <br>             |  |
| <b>LCPLA [m]</b> | Complement Data Memory with result in ACC  |
| Description      | Each bit of the specified Data Memory is logically complemented (1's complement). Bits which previously contained a 1 are changed to 0 and vice versa. The complemented result is stored in the Accumulator and the contents of the Data Memory remain unchanged.  |
| Operation        | $ACC \leftarrow \overline{[m]}$  |
| Affected flag(s) | Z  |
| <br>             |  |
| <b>LDAA [m]</b>  | Decimal-Adjust ACC for addition with result in Data Memory   |
| Description      | Convert the contents of the Accumulator value to a BCD (Binary Coded Decimal) value resulting from the previous addition of two BCD variables. If the low nibble is greater than 9 or if AC flag is set, then a value of 6 will be added to the low nibble. Otherwise the low nibble remains unchanged. If the high nibble is greater than 9 or if the C flag is set, then a value of 6 will be added to the high nibble. Essentially, the decimal conversion is performed by adding 00H, 06H, 60H or 66H depending on the Accumulator and flag conditions. Only the C flag may be affected by this instruction which indicates that if the original BCD sum is greater than 100, it allows multiple precision decimal addition. |
| Operation        | $[m] \leftarrow ACC + 00H$ or<br>$[m] \leftarrow ACC + 06H$ or<br>$[m] \leftarrow ACC + 60H$ or<br>$[m] \leftarrow ACC + 66H$  |
| Affected flag(s) | C  |
| <br>             |  |
| <b>LDEC [m]</b>  | Decrement Data Memory  |
| Description      | Data in the specified Data Memory is decremented by 1.   |
| Operation        | $[m] \leftarrow [m] - 1$   |
| Affected flag(s) | Z  |
| <br>             |  |
| <b>LDECA [m]</b> | Decrement Data Memory with result in ACC   |
| Description      | Data in the specified Data Memory is decremented by 1. The result is stored in the Accumulator. The contents of the Data Memory remain unchanged.  |
| Operation        | $ACC \leftarrow [m] - 1$   |
| Affected flag(s) | Z  |
| <br>             |  |
| <b>LINC [m]</b>  | Increment Data Memory  |
| Description      | Data in the specified Data Memory is incremented by 1.   |
| Operation        | $[m] \leftarrow [m] + 1$   |
| Affected flag(s) | Z  |
| <br>             |  |
| <b>LINCA [m]</b> | Increment Data Memory with result in ACC   |
| Description      | Data in the specified Data Memory is incremented by 1. The result is stored in the Accumulator. The contents of the Data Memory remain unchanged.  |
| Operation        | $ACC \leftarrow [m] + 1$   |
| Affected flag(s) | Z  |

|                   |   |
|-------------------|---|
| <b>LMOV A,[m]</b> | Move Data Memory to ACC   |
| Description       | The contents of the specified Data Memory are copied to the Accumulator.  |
| Operation         | $ACC \leftarrow [m]$  |
| Affected flag(s)  | None  |
| <b>LMOV [m],A</b> | Move ACC to Data Memory   |
| Description       | The contents of the Accumulator are copied to the specified Data Memory.  |
| Operation         | $[m] \leftarrow ACC$  |
| Affected flag(s)  | None  |
| <b>LOR A,[m]</b>  | Logical OR Data Memory to ACC   |
| Description       | Data in the Accumulator and the specified Data Memory perform a bitwise logical OR operation. The result is stored in the Accumulator.  |
| Operation         | $ACC \leftarrow ACC \text{ "OR" } [m]$  |
| Affected flag(s)  | Z   |
| <b>LORM A,[m]</b> | Logical OR ACC to Data Memory   |
| Description       | Data in the specified Data Memory and the Accumulator perform a bitwise logical OR operation. The result is stored in the Data Memory.  |
| Operation         | $[m] \leftarrow ACC \text{ "OR" } [m]$  |
| Affected flag(s)  | Z   |
| <b>LRL [m]</b>    | Rotate Data Memory left   |
| Description       | The contents of the specified Data Memory are rotated left by 1 bit with bit 7 rotated into bit 0.  |
| Operation         | $[m].(i+1) \leftarrow [m].i; (i=0\sim 6)$<br>$[m].0 \leftarrow [m].7$   |
| Affected flag(s)  | None  |
| <b>LRLA [m]</b>   | Rotate Data Memory left with result in ACC  |
| Description       | The contents of the specified Data Memory are rotated left by 1 bit with bit 7 rotated into bit 0. The rotated result is stored in the Accumulator and the contents of the Data Memory remain unchanged.  |
| Operation         | $ACC.(i+1) \leftarrow [m].i; (i=0\sim 6)$<br>$ACC.0 \leftarrow [m].7$   |
| Affected flag(s)  | None  |
| <b>LRLC [m]</b>   | Rotate Data Memory left through Carry   |
| Description       | The contents of the specified Data Memory and the carry flag are rotated left by 1 bit. Bit 7 replaces the Carry bit and the original carry flag is rotated into bit 0.   |
| Operation         | $[m].(i+1) \leftarrow [m].i; (i=0\sim 6)$<br>$[m].0 \leftarrow C$<br>$C \leftarrow [m].7$   |
| Affected flag(s)  | C   |
| <b>LRLCA [m]</b>  | Rotate Data Memory left through Carry with result in ACC  |
| Description       | Data in the specified Data Memory and the carry flag are rotated left by 1 bit. Bit 7 replaces the Carry bit and the original carry flag is rotated into the bit 0. The rotated result is stored in the Accumulator and the contents of the Data Memory remain unchanged. |
| Operation         | $ACC.(i+1) \leftarrow [m].i; (i=0\sim 6)$<br>$ACC.0 \leftarrow C$<br>$C \leftarrow [m].7$   |
| Affected flag(s)  | C   |

|                    |   |
|--------------------|---|
| <b>LRR [m]</b>     | Rotate Data Memory right  |
| Description        | The contents of the specified Data Memory are rotated right by 1 bit with bit 0 rotated into bit 7.   |
| Operation          | $[m].i \leftarrow [m].(i+1); (i=0\sim 6)$<br>$[m].7 \leftarrow [m].0$   |
| Affected flag(s)   | None  |
| <b>LRRRA [m]</b>   | Rotate Data Memory right with result in ACC   |
| Description        | Data in the specified Data Memory is rotated right by 1 bit with bit 0 rotated into bit 7. The rotated result is stored in the Accumulator and the contents of the Data Memory remain unchanged.  |
| Operation          | $ACC.i \leftarrow [m].(i+1); (i=0\sim 6)$<br>$ACC.7 \leftarrow [m].0$   |
| Affected flag(s)   | None  |
| <b>LRRC [m]</b>    | Rotate Data Memory right through Carry  |
| Description        | The contents of the specified Data Memory and the carry flag are rotated right by 1 bit. Bit 0 replaces the Carry bit and the original carry flag is rotated into bit 7.  |
| Operation          | $[m].i \leftarrow [m].(i+1); (i=0\sim 6)$<br>$[m].7 \leftarrow C$<br>$C \leftarrow [m].0$   |
| Affected flag(s)   | C   |
| <b>LRRCA [m]</b>   | Rotate Data Memory right through Carry with result in ACC   |
| Description        | Data in the specified Data Memory and the carry flag are rotated right by 1 bit. Bit 0 replaces the Carry bit and the original carry flag is rotated into bit 7. The rotated result is stored in the Accumulator and the contents of the Data Memory remain unchanged.  |
| Operation          | $ACC.i \leftarrow [m].(i+1); (i=0\sim 6)$<br>$ACC.7 \leftarrow C$<br>$C \leftarrow [m].0$   |
| Affected flag(s)   | C   |
| <b>LSBC A,[m]</b>  | Subtract Data Memory from ACC with Carry  |
| Description        | The contents of the specified Data Memory and the complement of the carry flag are subtracted from the Accumulator. The result is stored in the Accumulator. Note that if the result of subtraction is negative, the C flag will be cleared to 0, otherwise if the result is positive or zero, the C flag will be set to 1. |
| Operation          | $ACC \leftarrow ACC - [m] - \bar{C}$  |
| Affected flag(s)   | OV, Z, AC, C, SC, CZ  |
| <b>LSBCM A,[m]</b> | Subtract Data Memory from ACC with Carry and result in Data Memory  |
| Description        | The contents of the specified Data Memory and the complement of the carry flag are subtracted from the Accumulator. The result is stored in the Data Memory. Note that if the result of subtraction is negative, the C flag will be cleared to 0, otherwise if the result is positive or zero, the C flag will be set to 1. |
| Operation          | $[m] \leftarrow ACC - [m] - \bar{C}$  |
| Affected flag(s)   | OV, Z, AC, C, SC, CZ  |

|                   |   |
|-------------------|---|
| <b>LSDZ [m]</b>   | Skip if decrement Data Memory is 0  |
| Description       | The contents of the specified Data Memory are first decremented by 1. If the result is 0 the following instruction is skipped. As this requires the insertion of a dummy instruction while the next instruction is fetched, it is a two cycle instruction. If the result is not 0 the program proceeds with the following instruction.  |
| Operation         | $[m] \leftarrow [m] - 1$<br>Skip if $[m]=0$   |
| Affected flag(s)  | None  |
| <b>LSDZA [m]</b>  | Skip if decrement Data Memory is zero with result in ACC  |
| Description       | The contents of the specified Data Memory are first decremented by 1. If the result is 0, the following instruction is skipped. The result is stored in the Accumulator but the specified Data Memory contents remain unchanged. As this requires the insertion of a dummy instruction while the next instruction is fetched, it is a two cycle instruction. If the result is not 0, the program proceeds with the following instruction. |
| Operation         | $ACC \leftarrow [m] - 1$<br>Skip if $ACC=0$   |
| Affected flag(s)  | None  |
| <b>LSET [m]</b>   | Set Data Memory   |
| Description       | Each bit of the specified Data Memory is set to 1.  |
| Operation         | $[m] \leftarrow FFH$  |
| Affected flag(s)  | None  |
| <b>LSET [m].i</b> | Set bit of Data Memory  |
| Description       | Bit i of the specified Data Memory is set to 1.   |
| Operation         | $[m].i \leftarrow 1$  |
| Affected flag(s)  | None  |
| <b>LSIZ [m]</b>   | Skip if increment Data Memory is 0  |
| Description       | The contents of the specified Data Memory are first incremented by 1. If the result is 0, the following instruction is skipped. As this requires the insertion of a dummy instruction while the next instruction is fetched, it is a two cycle instruction. If the result is not 0 the program proceeds with the following instruction.   |
| Operation         | $[m] \leftarrow [m] + 1$<br>Skip if $[m]=0$   |
| Affected flag(s)  | None  |
| <b>LSIZA [m]</b>  | Skip if increment Data Memory is zero with result in ACC  |
| Description       | The contents of the specified Data Memory are first incremented by 1. If the result is 0, the following instruction is skipped. The result is stored in the Accumulator but the specified Data Memory contents remain unchanged. As this requires the insertion of a dummy instruction while the next instruction is fetched, it is a two cycle instruction. If the result is not 0 the program proceeds with the following instruction.  |
| Operation         | $ACC \leftarrow [m] + 1$<br>Skip if $ACC=0$   |
| Affected flag(s)  | None  |
| <b>LSNZ [m].i</b> | Skip if Data Memory is not 0  |
| Description       | If the specified Data Memory is not 0, the following instruction is skipped. As this requires the insertion of a dummy instruction while the next instruction is fetched, it is a two cycle instruction. If the result is 0 the program proceeds with the following instruction.  |
| Operation         | Skip if $[m].i \neq 0$  |
| Affected flag(s)  | None  |

|                    |  |
|--------------------|--|
| <b>LSNZ [m]</b>    | Skip if Data Memory is not 0   |
| Description        | If the content of the specified Data Memory is not 0, the following instruction is skipped. As this requires the insertion of a dummy instruction while the next instruction is fetched, it is a two cycle instruction. If the result is 0 the program proceeds with the following instruction.  |
| Operation          | Skip if [m] ≠ 0  |
| Affected flag(s)   | None   |
|                    |  |
| <b>LSUB A,[m]</b>  | Subtract Data Memory from ACC  |
| Description        | The specified Data Memory is subtracted from the contents of the Accumulator. The result is stored in the Accumulator. Note that if the result of subtraction is negative, the C flag will be cleared to 0, otherwise if the result is positive or zero, the C flag will be set to 1.  |
| Operation          | ACC ← ACC – [m]  |
| Affected flag(s)   | OV, Z, AC, C, SC, CZ   |
|                    |  |
| <b>LSUBM A,[m]</b> | Subtract Data Memory from ACC with result in Data Memory   |
| Description        | The specified Data Memory is subtracted from the contents of the Accumulator. The result is stored in the Data Memory. Note that if the result of subtraction is negative, the C flag will be cleared to 0, otherwise if the result is positive or zero, the C flag will be set to 1.  |
| Operation          | [m] ← ACC – [m]  |
| Affected flag(s)   | OV, Z, AC, C, SC, CZ   |
|                    |  |
| <b>LSWAP [m]</b>   | Swap nibbles of Data Memory  |
| Description        | The low-order and high-order nibbles of the specified Data Memory are interchanged.  |
| Operation          | [m].3~[m].0 ↔ [m].7~[m].4  |
| Affected flag(s)   | None   |
|                    |  |
| <b>LSWAPA [m]</b>  | Swap nibbles of Data Memory with result in ACC   |
| Description        | The low-order and high-order nibbles of the specified Data Memory are interchanged. The result is stored in the Accumulator. The contents of the Data Memory remain unchanged.   |
| Operation          | ACC.3~ACC.0 ← [m].7~[m].4<br>ACC.7~ACC.4 ← [m].3~[m].0   |
| Affected flag(s)   | None   |
|                    |  |
| <b>LSZ [m]</b>     | Skip if Data Memory is 0   |
| Description        | If the contents of the specified Data Memory is 0, the following instruction is skipped. As this requires the insertion of a dummy instruction while the next instruction is fetched, it is a two cycle instruction. If the result is not 0 the program proceeds with the following instruction.   |
| Operation          | Skip if [m]=0  |
| Affected flag(s)   | None   |
|                    |  |
| <b>LSZA [m]</b>    | Skip if Data Memory is 0 with data movement to ACC   |
| Description        | The contents of the specified Data Memory are copied to the Accumulator. If the value is zero, the following instruction is skipped. As this requires the insertion of a dummy instruction while the next instruction is fetched, it is a two cycle instruction. If the result is not 0 the program proceeds with the following instruction. |
| Operation          | ACC ← [m]<br>Skip if [m]=0   |
| Affected flag(s)   | None   |

|                     |  |
|---------------------|--|
| <b>LSZ [m].i</b>    | Skip if bit i of Data Memory is 0  |
| Description         | If bit i of the specified Data Memory is 0, the following instruction is skipped. As this requires the insertion of a dummy instruction while the next instruction is fetched, it is a two cycle instruction. If the result is not 0, the program proceeds with the following instruction. |
| Operation           | Skip if [m].i=0  |
| Affected flag(s)    | None   |
| <br>                |  |
| <b>LTABRD [m]</b>   | Read table (current page) to TBLH and Data Memory  |
| Description         | The low byte of the program code (current page) addressed by the table pointer (TBLP) is moved to the specified Data Memory and the high byte moved to TBLH.   |
| Operation           | [m] ← program code (low byte)<br>TBLH ← program code (high byte)   |
| Affected flag(s)    | None   |
| <br>                |  |
| <b>LTABRDL [m]</b>  | Read table (last page) to TBLH and Data Memory   |
| Description         | The low byte of the program code (last page) addressed by the table pointer (TBLP) is moved to the specified Data Memory and the high byte moved to TBLH.  |
| Operation           | [m] ← program code (low byte)<br>TBLH ← program code (high byte)   |
| Affected flag(s)    | None   |
| <br>                |  |
| <b>LITABRD [m]</b>  | Increment table pointer low byte first and read table to TBLH and Data Memory  |
| Description         | Increment table pointer low byte, TBLP, first and then the program code addressed by the table pointer (TBLP and TBLP) is moved to the specified Data Memory and the high byte moved to TBLH.  |
| Operation           | [m] ← program code (low byte)<br>TBLH ← program code (high byte)   |
| Affected flag(s)    | None   |
| <br>                |  |
| <b>LITABRDL [m]</b> | Increment table pointer low byte first and read table (last page) to TBLH and Data Memory  |
| Description         | Increment table pointer low byte, TBLP, first and then the low byte of the program code (last page) addressed by the table pointer (TBLP) is moved to the specified Data Memory and the high byte moved to TBLH.   |
| Operation           | [m] ← program code (low byte)<br>TBLH ← program code (high byte)   |
| Affected flag(s)    | None   |
| <br>                |  |
| <b>LXOR A,[m]</b>   | Logical XOR Data Memory to ACC   |
| Description         | Data in the Accumulator and the specified Data Memory perform a bitwise logical XOR operation. The result is stored in the Accumulator.  |
| Operation           | ACC ← ACC "XOR" [m]  |
| Affected flag(s)    | Z  |
| <br>                |  |
| <b>LXORM A,[m]</b>  | Logical XOR ACC to Data Memory   |
| Description         | Data in the specified Data Memory and the Accumulator perform a bitwise logical XOR operation. The result is stored in the Data Memory.  |
| Operation           | [m] ← ACC "XOR" [m]  |
| Affected flag(s)    | Z  |

## Package Information

Note that the package information provided here is for consultation purposes only. As this information may be updated at regular intervals users are reminded to consult

Additional supplementary information with regard to packaging is listed below. Click on the relevant section to be transferred to the relevant website page.

- [Package Information \(include Outline Dimensions, Product Tape and Reel Specifications\)](#)
- [The Operation Instruction of Packing Materials](#)
- [Carton information](#)

48-pin LQFP (7mm×7mm) Outline Dimensions

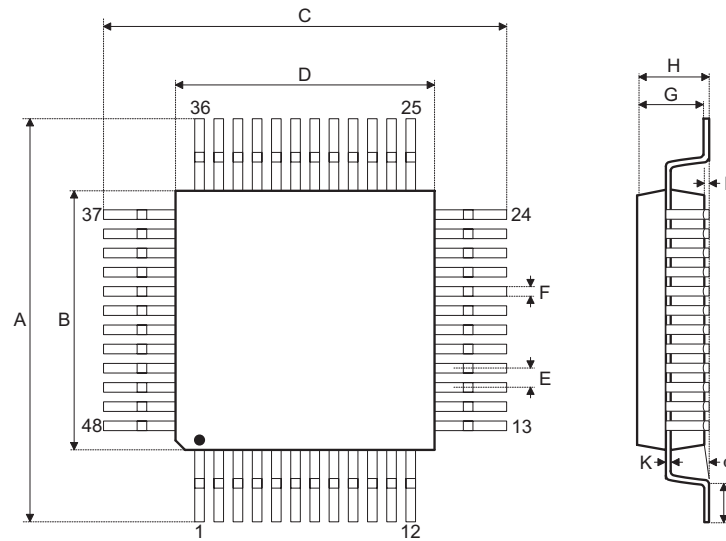

| Symbol | Dimensions in inch |           |       |
|--------|--------------------|-----------|-------|
|        | Min.               | Nom.      | Max.  |
| A      | —                  | 0.354 BSC | —     |
| B      | —                  | 0.276 BSC | —     |
| C      | —                  | 0.354 BSC | —     |
| D      | —                  | 0.276 BSC | —     |
| E      | —                  | 0.020 BSC | —     |
| F      | 0.007              | 0.009     | 0.011 |
| G      | 0.053              | 0.055     | 0.057 |
| H      | —                  | —         | 0.063 |
| I      | 0.002              | —         | 0.006 |
| J      | 0.018              | 0.024     | 0.030 |
| K      | 0.004              | —         | 0.008 |
| α      | 0°                 | —         | 7°    |

| Symbol | Dimensions in mm |          |      |
|--------|------------------|----------|------|
|        | Min.             | Nom.     | Max. |
| A      | —                | 9.00 BSC | —    |
| B      | —                | 7.00 BSC | —    |
| C      | —                | 9.00 BSC | —    |
| D      | —                | 7.00 BSC | —    |
| E      | —                | 0.50 BSC | —    |
| F      | 0.17             | 0.22     | 0.27 |
| G      | 1.35             | 1.40     | 1.45 |
| H      | —                | —        | 1.60 |
| I      | 0.05             | —        | 0.15 |
| J      | 0.45             | 0.60     | 0.75 |
| K      | 0.09             | —        | 0.20 |
| α      | 0°               | —        | 7°   |

64-pin LQFP (7mm×7mm) Outline Dimensions

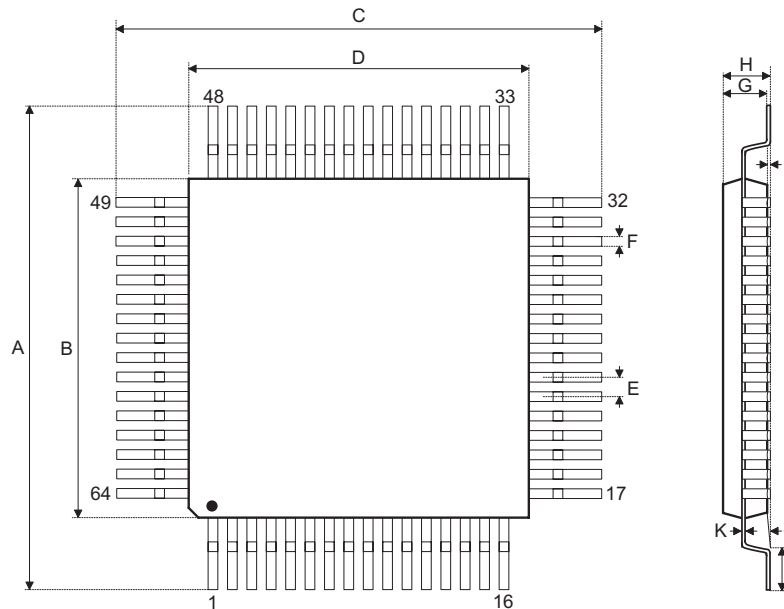

| Symbol | Dimensions in inch |           |       |
|--------|--------------------|-----------|-------|
|        | Min.               | Nom.      | Max.  |
| A      | —                  | 0.354 BSC | —     |
| B      | —                  | 0.276 BSC | —     |
| C      | —                  | 0.354 BSC | —     |
| D      | —                  | 0.276 BSC | —     |
| E      | —                  | 0.016 BSC | —     |
| F      | 0.005              | 0.007     | 0.009 |
| G      | 0.053              | 0.055     | 0.057 |
| H      | —                  | —         | 0.063 |
| I      | 0.002              | —         | 0.006 |
| J      | 0.018              | 0.024     | 0.030 |
| K      | 0.004              | —         | 0.008 |
| α      | 0°                 | —         | 7°    |

| Symbol | Dimensions in mm |          |      |
|--------|------------------|----------|------|
|        | Min.             | Nom.     | Max. |
| A      | —                | 9.00 BSC | —    |
| B      | —                | 7.00 BSC | —    |
| C      | —                | 9.00 BSC | —    |
| D      | —                | 7.00 BSC | —    |
| E      | —                | 0.40 BSC | —    |
| F      | 0.13             | 0.18     | 0.23 |
| G      | 1.35             | 1.40     | 1.45 |
| H      | —                | —        | 1.60 |
| I      | 0.05             | —        | 0.15 |
| J      | 0.45             | 0.60     | 0.75 |
| K      | 0.09             | —        | 0.20 |
| α      | 0°               | —        | 7°   |

Copyright© 2019 by HOLTEK SEMICONDUCTOR INC.

The information appearing in this Data Sheet is believed to be accurate at the time of publication. However, Holtek assumes no responsibility arising from the use of the specifications described. The applications mentioned herein are used solely for the purpose of illustration and Holtek makes no warranty or representation that such applications will be suitable without further modification, nor recommends the use of its products for application that may present a risk to human life due to malfunction or otherwise. Holtek's products are not authorized for use as critical components in life support devices or systems. Holtek reserves the right to alter its products without prior notification.